

EI-5276

Ages 6 & up

# DELUXE MAGNISCOPE™

## Instruction and Activity Guide

**Educational  
Insights®**



EI-5276

*Grow, collect, prepare, and observe the fascinating microscopic  
creatures and plants all around you!*

**Educational  
Insights®**



# DELUXE MAGNISCOPE

## Instruction and Activity Guide

Written by Carolyn Jeffries

Illustrated by Leonid Rabinovich

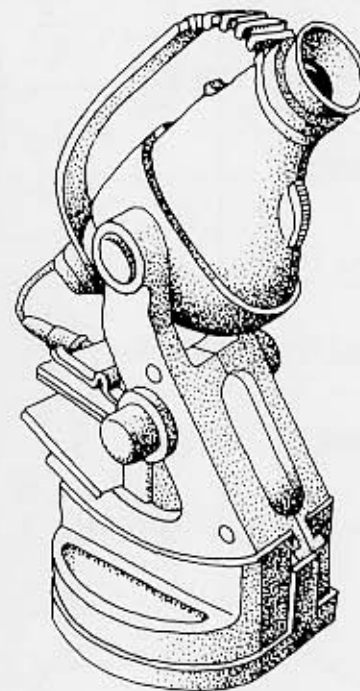

Educational  
Insights®



© Copyright 1996 Educational Insights

Carson, CA (USA) • St Albans, Herts. (UK)

All rights reserved. No part of this publication may be reproduced, stored in a retrieval system, or transmitted in any form or by any means, including electronic, mechanical, recording, or otherwise, without written permission of the publisher.

ISBN 1-56767-118-7

Made in China



**WARNING:** CHOKING HAZARD—  
Small parts. Not for children under three (3) years.

### CAUTION

Never look directly at the sun with the Deluxe Magniscope or allow sunlight to reflect directly through the lens to your eye. Viewing the sun can cause permanent eye damage.

## TABLE OF CONTENTS

THE MICROSCOPIC WORLD .....	3
THE DELUXE MAGNISCOPE KIT .....	4
VIEWING METHODS .....	6
TECHNIQUES TO TRY .....	10
EXPLORING UNSEEN TERRITORIES .....	11
EXPERIMENTS AND ACTIVITIES .....	13
CARE OF THE DELUXE MAGNISCOPE .....	25

## THE MICROSCOPIC WORLD



Have you ever wondered what your skin and hair look like under a microscope, what kind of creatures live in puddles, what the green fuzzy stuff growing on old bread is, or how crystals change as they grow? There is a fascinating unseen world teeming with life all around you. You cannot see it because it is microscopic—too small to be seen with your eyes only—but now you can see all kinds of microscopic things clearly using the Deluxe MagniScope!

# THE DELUXE MAGNISCOPE KIT

## Parts and Accessories

The Deluxe MagniScope Kit contains all you need to explore the microscopic world around you.

### Deluxe MagniScope

BrightSpot Light  
(Located in bottom storage compartment)

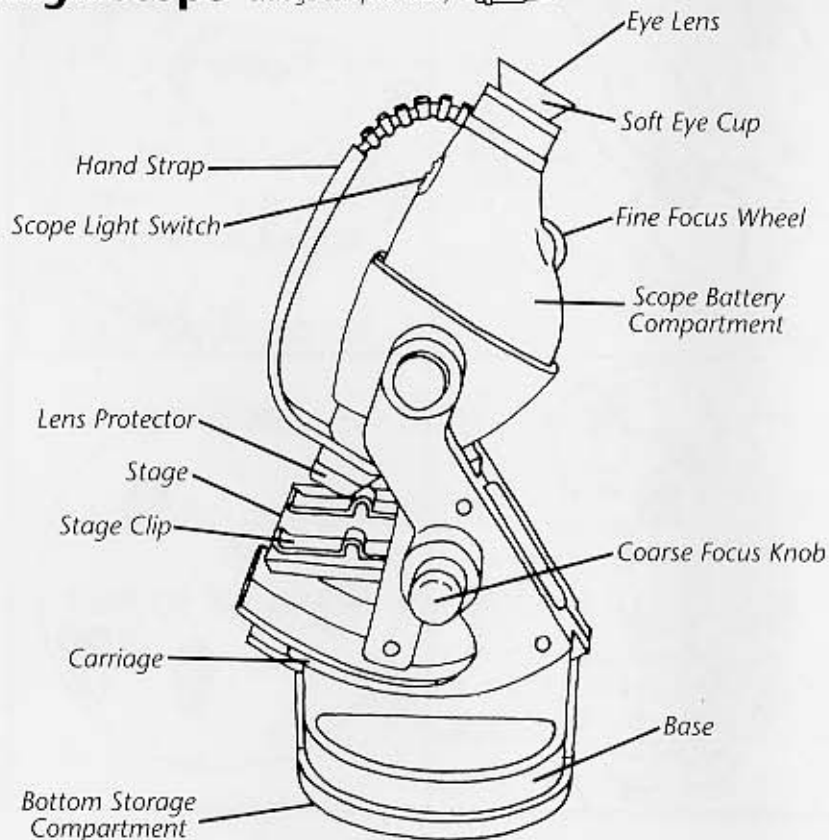

### Accessories



Blank Labels and cover slips



Microaquarium™



Water Dropper



Tweezers



Specimen Holder

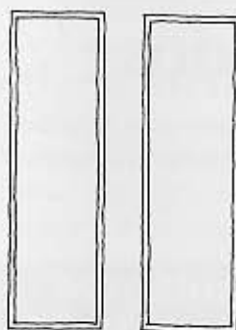

Slides



Sea Salt (white)



Brine Shrimp Eggs (brown)



Hatchery

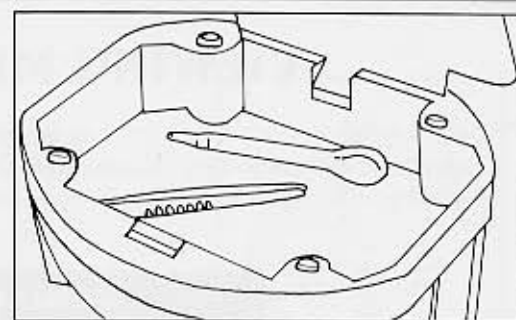

### Storing the Accessories

The base of your Deluxe MagniScope has plenty of room for the brightspot light, accessories, and even any dry samples you may collect. Turn over the MagniScope and open the bottom storage compartment. Place the items you wish to store inside. Then snap the compartment cover closed to secure everything for easy carrying.

### Inserting Battery

The light bulb in the brightspot light requires one fresh AA battery, which is placed in the scope battery compartment (see page 4 for battery compartment location). To remove the battery compartment cover in the Deluxe MagniScope handle, loosen and remove the screw. Install one fresh AA battery inside the battery compartment as shown in the diagram. Attach the battery compartment cover and insert and tighten the screw. Be careful not to overtighten the screw.

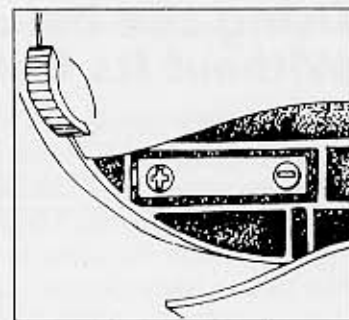

- Batteries must be inserted with the correct polarity.
- Do not mix old and new batteries. Do not mix alkaline, standard (carbon-zinc), or rechargeable (nickel-cadmium) batteries.
- Remove exhausted batteries from the machine.
- The supply terminals must not be short circuited.
- Non-rechargeable batteries must not be recharged.
- Do not use rechargeable batteries.
- Only batteries of the same or equivalent type as recommended are to be used.

# VIEWING METHODS

There are many ways an object can be viewed using your microscope. Experiment with any method you wish or use the following table and information as a guide.

## Deluxe MagniScope Viewing Methods to Try

Object Size	Object Is Dry	Object Is in Liquid
greater than 1.25 cm (½ inch)	<ul style="list-style-type: none"> <li>• free hand method</li> <li>• thin section viewing method</li> </ul>	<ul style="list-style-type: none"> <li>• free hand method</li> </ul>
between 1.25 cm (½ inch) and 0.3 cm (⅛ inch)	<ul style="list-style-type: none"> <li>• free hand method</li> <li>• slide method</li> </ul>	<ul style="list-style-type: none"> <li>• slide method</li> </ul>
less than 0.3 cm (⅛ inch)	<ul style="list-style-type: none"> <li>• slide method</li> </ul>	<ul style="list-style-type: none"> <li>• microaquarium method</li> <li>• slide method</li> </ul>

## Using the Deluxe MagniScope Without Its Base

To detach the Deluxe MagniScope from its base, disconnect the brightspot light from the scope, then hold the base with one hand and slip the MagniScope out of its holster with the other hand. Now hold the Deluxe MagniScope steady with your fingers under the hand strap and your thumb under the scope.

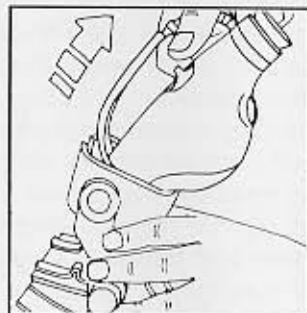

Attach the brightspot light by plugging in the ends as shown. Switch on the scope light and bring an object into focus by turning the fine focus wheel until you can clearly see the object. When you are finished viewing, switch off the brightspot light.

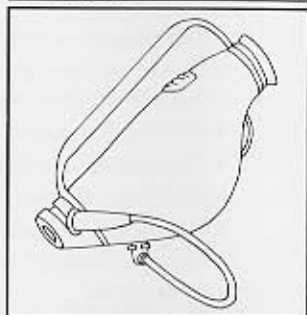

## Free Hand Method

Place the Deluxe MagniScope clear lens protector against the object you wish to view. If you need more light, turn on the brightspot light and bring the object into focus.



## MicroAquarium Method

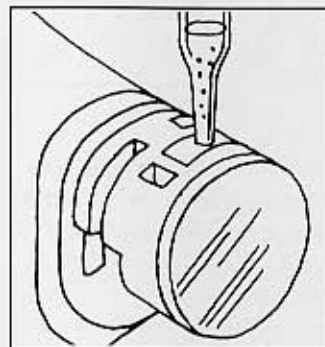

Slide the microaquarium onto the end of Deluxe MagniScope. Use the dropper to carefully add a drop of liquid into the hole at the top of the microaquarium. To see an object in the liquid, point the microaquarium toward a bright light bulb or switch on the brightspot light. Or, try both lighting methods at the same time. Focus using the focus wheel.

## CAUTION

Never look directly at the sun with the Deluxe MagniScope or allow sunlight to reflect directly through the lens to your eye. Viewing the sun can cause permanent eye damage.

## Thin Section Viewing Method

Place the object you wish to view in a specimen holder and slide the specimen holder onto the end of the Deluxe MagniScope. Switch on the light and focus using the focus wheel.

Some interesting things to observe using the specimen holder are tree bark, grass, leaves, feathers, tissue paper, cloth, stamps, and yarn!

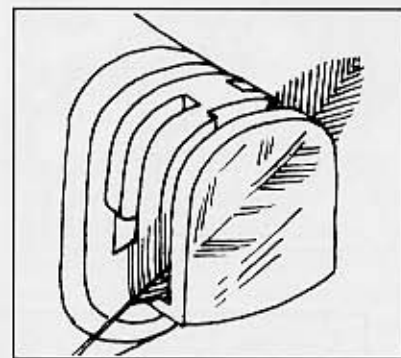

## Using the Deluxe MagniScope With Its Base

The Deluxe MagniScope comes with a two-way adjustable base. To mount the Deluxe MagniScope to its base, disconnect the brightspot light, then slide the scope into the holster as shown.

To adjust the holster angle, move the holster to the desired position. As you can see in the diagram below, the holster can be set to any one of several adjustment stops.

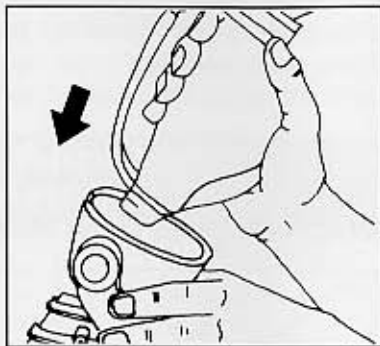
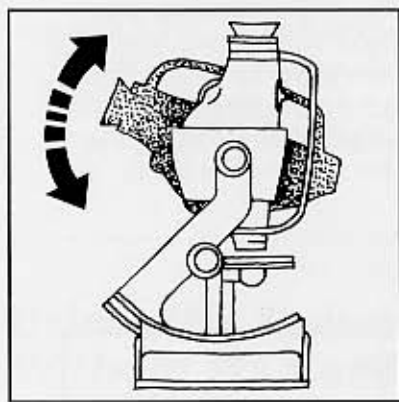

To adjust the carriage position, unlock the carriage brake, rotate the carriage to any position between 45 and 90 degrees and relock the brake.

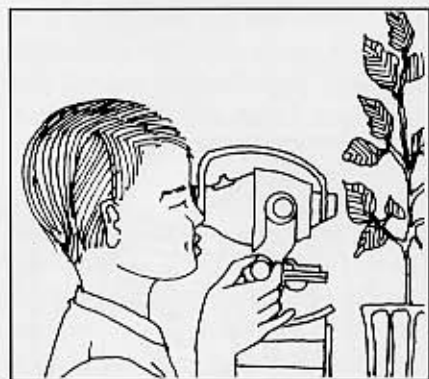
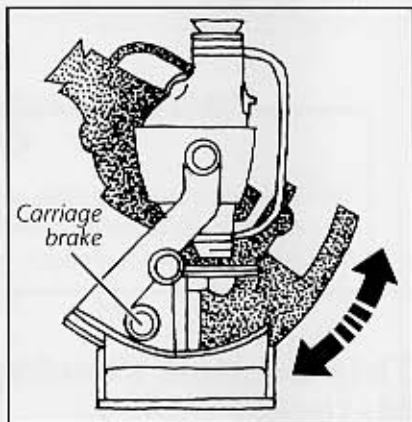

Both the holster and the carriage can be adjusted to give many viewing angles. Experiment with various angles to see which are best for you and your viewing needs.

**Caution:** The scope carriage will only move 45 degrees. If it is forced further than that, it will break.

## Slide Method

To prepare a slide of an object, place a drop of water in the center of a clean slide.

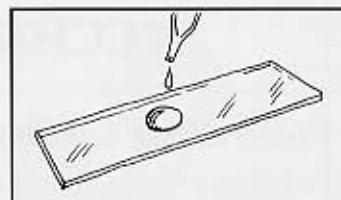

Use the tweezers to place the object in the drop of water. (If the object is already in water, place a drop of it in the center of a clean slide.)

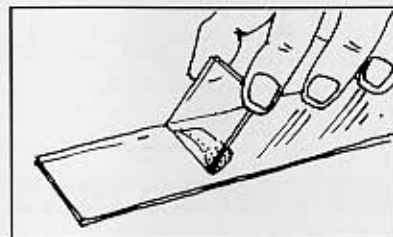
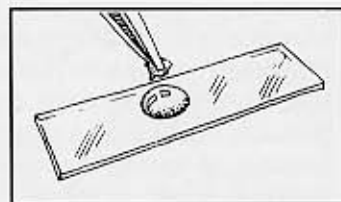

To place a coverslip over the object, hold the coverslip at a 45° angle to the drop of water and carefully lower the edge onto the edge of the drop of water.

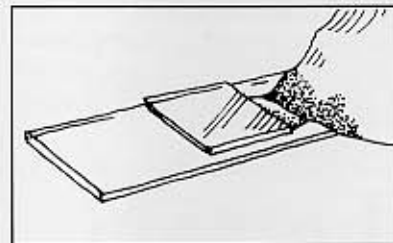

Gently lay the rest of the coverslip over the drop of water. Do not press down on it. Pressure may break the coverslip or squash the object. Remove any extra water that leaks outside the coverslip by blotting it with a tissue.

Next, place the slide on the stage, using the stage clips to hold the slide in place. Plug the brightspot light into the MagniScope and the front of the stage, then switch it on. Bring the object into focus by first turning the coarse focus knob and then turning the fine focus wheel until the object comes into focus.

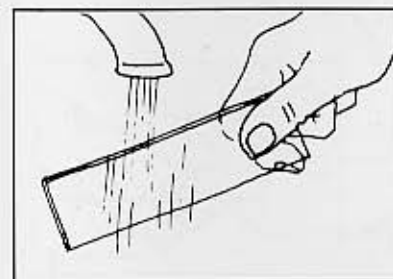
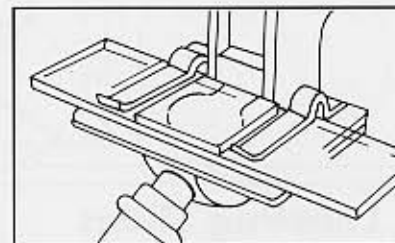

When you are finished with the slide, take it off the stage. Carefully lift off the coverslip. Rinse the slide and the coverslip with tap water and then air dry them. Or, wipe them with a clean, soft cloth. If the slide is very dirty, soak it before rinsing and air drying it.

## TECHNIQUES TO TRY

### Following Creatures

To follow a moving creature on a slide while looking through the Deluxe MagniScope, move the slide in the direction opposite to that of the creature. For example, if the creature seen through the Deluxe MagniScope is moving up and to the right, move the slide down and to the left to keep the creature in view.

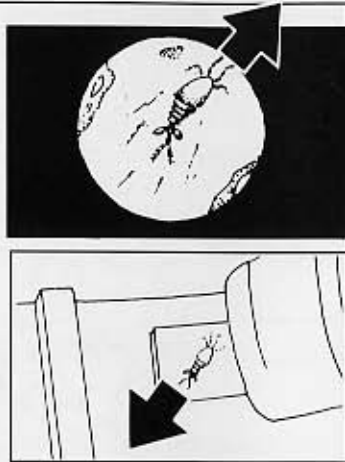

### Slowing Creatures

To slow a fast-moving creature on a slide, add a drop of corn syrup, some cotton threads, torn lens paper, or a single speck of yeast.

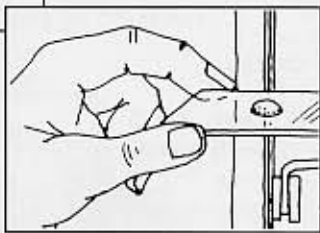
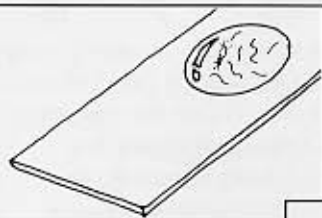

Cooling your creature for a **brief** period of time in the refrigerator will also slow its movements.

### Labeling Slides

To label a slide, write your message on a small piece of masking tape or on one of the blank labels included in the kit, then stick it onto one end of the slide.

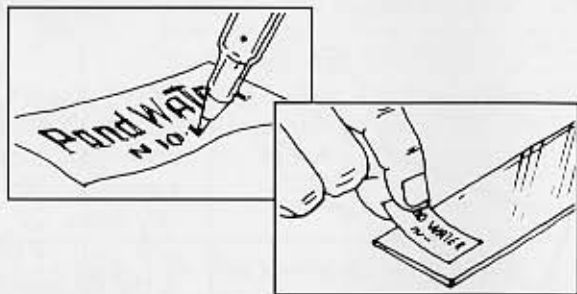

### Viewing Plant Parts

When a plant part is too thick for light to pass through, it must be cut into thin slices.

Experiment with thin slices of any plant you wish to see. Try looking at thin slices of stems, petals, leaves, roots, and fruit.

**Caution:** Be very careful and have an adult assist you when slicing plant parts.



## EXPLORING UNSEEN TERRITORIES

Now that you are familiar with the different ways you can use the Deluxe MagniScope, start exploring the exciting microscopic world around you. Try the suggestions below and draw what you see in the circles. Then do the activities and experiments that start on page 13.

- Compare different-colored hair, dyed hair, and permed hair.

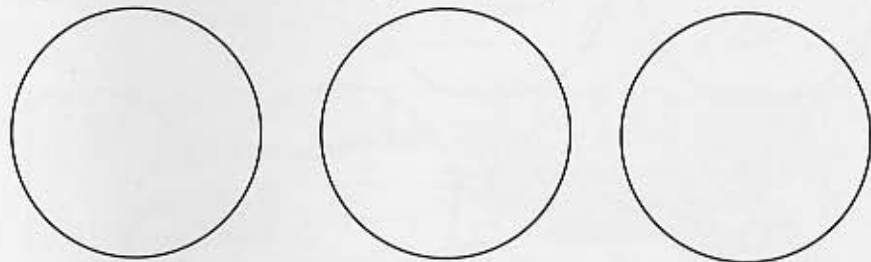

- Compare cat and dog fur.

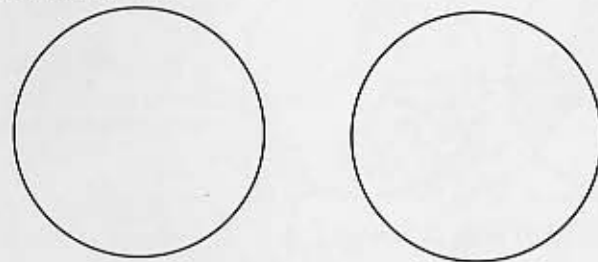

• Look at feathers, fingernails, butterfly and moth wings, and fish scales.

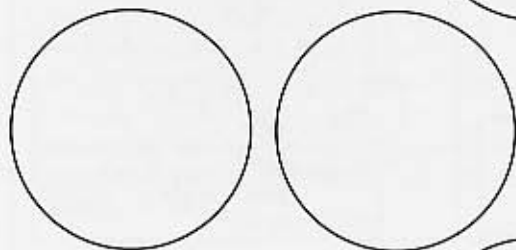
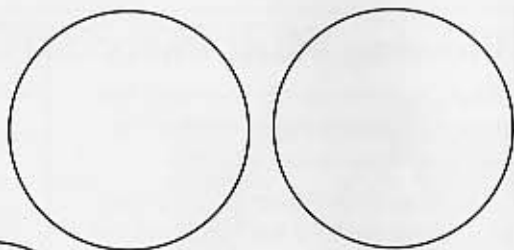

• See how different fabrics and fibers of clothes, furniture, and rugs are woven. Start by looking at the clothes you are wearing!

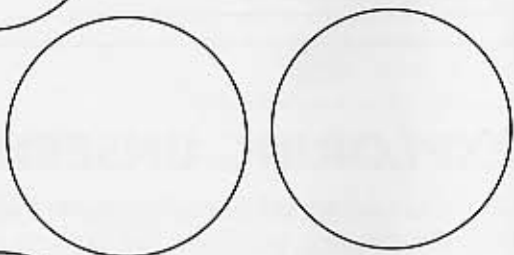

• Look at different-colored flower petals and leaves.

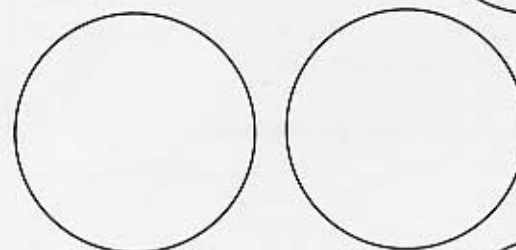

• Compare and identify the crystals in the rocks and gems you find around your house and yard.

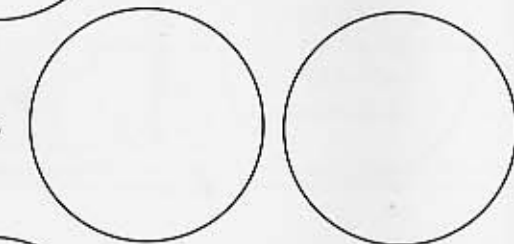

• Find and compare different types of molds, yeast, and mildew.

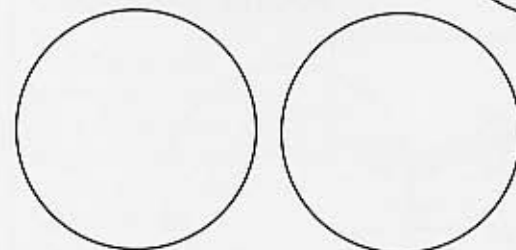

• Discover what's living in a rotting log or a compost heap.

Remember to label your drawings.

There are millions of things to explore using the Deluxe MagniScope!

## DELUXE MAGNISCOPE EXPERIMENTS AND ACTIVITIES

### Unseen Printed Colors

Have you ever wondered how the colors in newspapers and magazines are created and what they look like under a microscope? Do the following activities to find out how this is done and what happens to newsprint under magnification.



### Try This

Use the free hand method to observe as many different colored magazine and newspaper pictures and drawings as you can. In the table on the next page, list the colors of the dots used to create each printed color.

#### You Will Need:

- newspaper with colored illustrations
- colored magazine illustrations or pictures

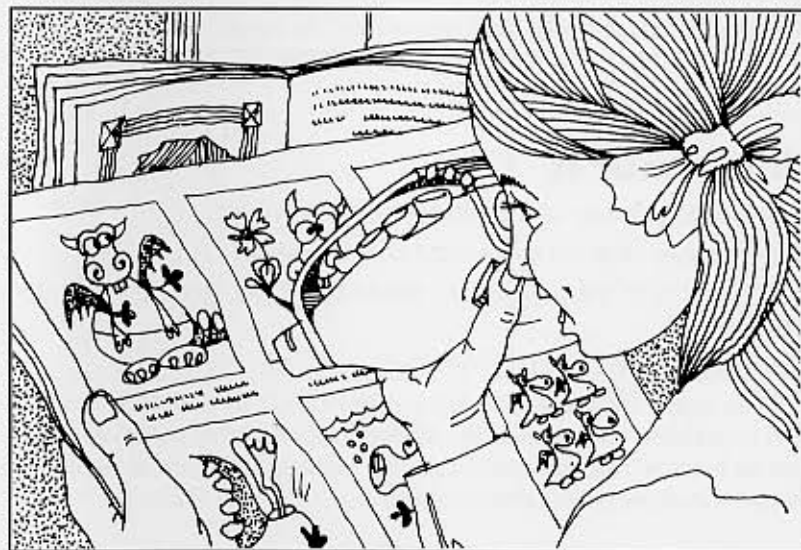

### Color of Dots Seen Under Deluxe MagniScope

Newsprint & Magazine Printed Color	Newspaper	Magazine
red		
orange		
yellow		
green		
purple		
blue		
brown		
pink		
gray		
other colors:		

### Think About It

Was every color made up of different colored dots?

Was there more of one colored dot than another?

Were the colors in the newspaper made up of the same colored dots as in the magazine?

Are dots used to create black? White?

Look at as many different-colored paper objects as you can—box labels, books, postcards, paper money, posters, etc. Are the colors made up of the same kind of colored dots? Do you see any differences or similarities between the objects and their colors?

### Explore Some More

Look at this “e” and “a” with the Deluxe MagniScope.

Draw what you see in the table.

As Seen by the Naked Eye	As Seen Under the Deluxe MagniScope
e	
a	

### Think About It

Two things happened to the letters with the Deluxe MagniScope. What were they?

### Explore Even More

Look again through the Deluxe MagniScope at some newsprint and move the MagniScope up, down, right, and then left. What happens?

Does the image move in the direction you thought it would? Put your findings in the table.

Direction the Deluxe MagniScope Moved	Direction You Thought the Image Would Move	Direction the Image Moved
up		
down		
right		
left		

In the free hand method the Deluxe MagniScope and the image move in the same direction, but they don't *seem* to because all things that you see under the Deluxe MagniScope are turned upside down and backwards.

# Growing Crystals

Through the ages people have been fascinated by crystals. Crystals have smooth, flat surfaces and sharp-edged corners. There are seven different types of crystals: cubic, tetragonal, triclinic, trigonal, orthorhombic, monoclinic, and hexagonal. The following experiment will help you see some of these shapes in some surprising places.

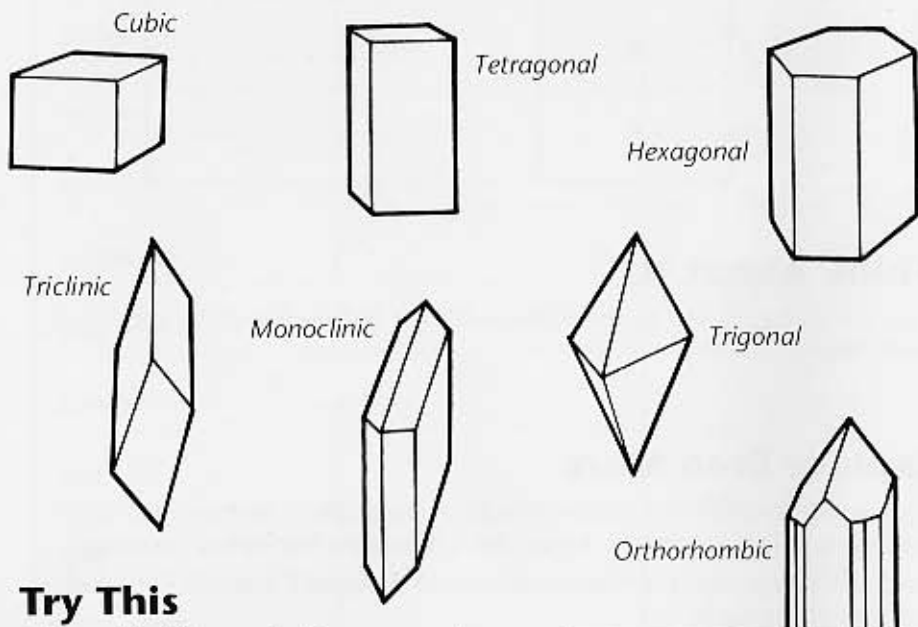

## Try This

Make a label for each of your samples and attach each to a separate slide. Using a spatula or small spoon, place a very small amount of each sample in the center of its labeled slide. Add a drop of hot water to the first sample and gently stir it with a toothpick.

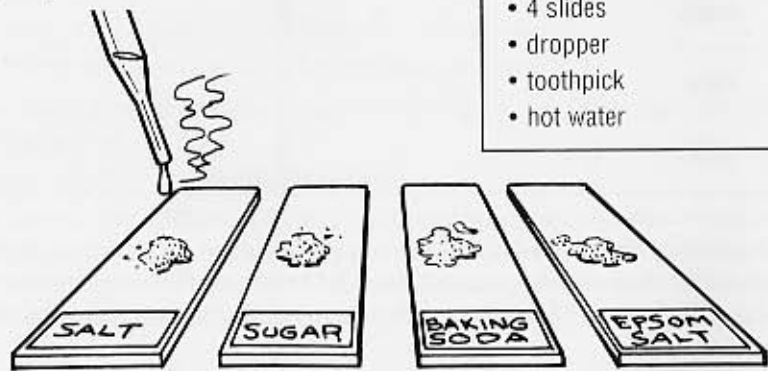

### You Will Need:

- small amounts of salt, sugar, baking soda, Epsom salts
- fine-point permanent marker
- masking tape
- spatula or small spoon
- 4 slides
- dropper
- toothpick
- hot water

Place the slide under the stage clips on the stage and look through the MagniScope at the crystal solution. As the solution cools, watch how the crystals form. Draw or write what you see in the Crystal Observation Table. Look at the crystal shapes on page 16 and decide the crystal shape of your sample; write it in the last column of the table. Repeat this procedure for each of the remaining samples.

## Crystal Observation Table

Sample	Observation/Drawing	Crystal Shape
salt		
sugar		
baking soda		
Epsom salts		
others:		

## Think About It

Does each sample form a certain type of crystal shape?

Which sample had the best crystals?

Now that you've explored some common materials you may want to test other materials. Try artificial sugar, flour, powdered drink mix, soap flakes, boric acid, and baking powder.

# Raising Brine Shrimp

Brine shrimp are easy to raise and fun to watch as they develop from eggs into adults. Do this activity to observe how brine shrimp hatch and grow into adults.

## You Will Need:

- small, clean jar (mayonnaise, peanut butter, and jelly jars work well)
- brine shrimp food, small pieces of lettuce, or dry yeast
- soft, clean towel
- measuring cup
- brine shrimp eggs
- microaquarium
- hatchery jar
- sea salt
- dropper
- large spoon
- small spoon



## Getting Ready

1. Rinse the jar with warm water (without soap or detergent.) Dry it with a soft, clean towel.
2. Fill the jar with 355 ml (12 ounces) of warm bottled water.
3. Empty all of the sea salt into the water.

4. Stir the water for one minute or until the salt is completely dissolved.
5. Set the jar in a safe, well-lit area. It should remain there (at room temperature—21°C or 70°F) for 24 to 36 hours.

## Hatching the Eggs

1. Pour the entire contents of the brine shrimp egg packet into the prepared water.
2. Stir the water for one minute until the contents of the package begin to dissolve.



3. Put the jar under a strong light or near a sunny window. Be careful not to spill the water! Brine shrimp grow best when the temperature is fairly constant—room temperature is best (21°C or 70°F).

4. After about three minutes, look at the jar. You may see some little white dots wiggling around in the water. These are newly hatched brine shrimp. Don't be discouraged if your eggs don't hatch right away. Brine shrimp eggs can take up to 36 hours to hatch. Once they do hatch, use the dropper to collect some of the eggs and wiggling hatchlings and look at them under your Deluxe Magni-Scope. The microaquarium method works best for this observation.

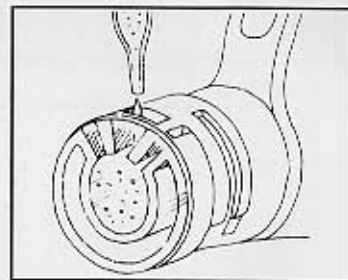

## Think About It

1. Draw what you see in the Brine Shrimp Observation Table on the next page. Have the eggs hatched? What color are the young brine shrimp? How many legs or arms can you count? Do they have eyes? Antennas?
2. Observe a drop of the mixture every hour for the next three hours and draw what you see. Make notes about anything unusual or interesting that occurs.

## Brine Shrimp Care and Growth

1. Make observations of your brine shrimp every day for five days.
2. After 7 days, feed the brine shrimp. Sprinkle one pinch of food on top of the water.
3. After 14 days count the number of brine shrimp in your jar.  
If you have fewer than 25, continue to feed them one pinch of food each week.  
If you have more than 25 brine shrimp, feed them two pinches of food per week.

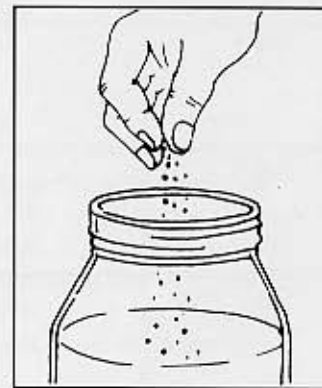

**NOTE: If the water becomes cloudy, you are feeding them too much and should wait until the water is clear before feeding again.**

4. Every few days make observations of the shrimp. You will eventually see a female with eggs near her tail! When you run out of room on the observation table, make a table of your own on a separate sheet of paper.

## Brine Shrimp Observation Table

Day/Hour	Notes and Drawings
Day 1 3 min.	
1 hour	
2 hours	
3 hours	
Day 2	
Day 3	
Day 4	
Day 5	
Day 7 (Feed)	
Day 9	
Day 14 (Feed)	

## Grow Even More Brine Shrimp

1. If all the brine shrimp should die, you can hatch new ones.
2. Let all the water in the jar evaporate—this may take several weeks. When dry, the bottom of the jar will be covered with white salt crystals and eggs.

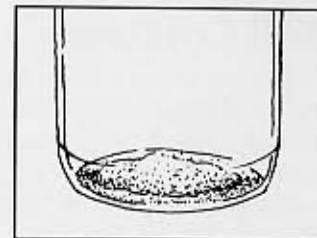

3. Add 355 ml (12 ounces) of bottled spring water to the dry jar.

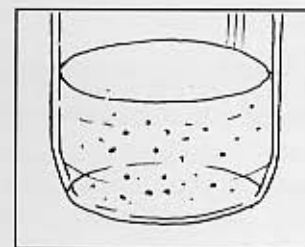

4. In a few days you'll see new young brine shrimp swimming around!
5. Follow the same feeding instructions as before.

## Using the Hatchery Jar

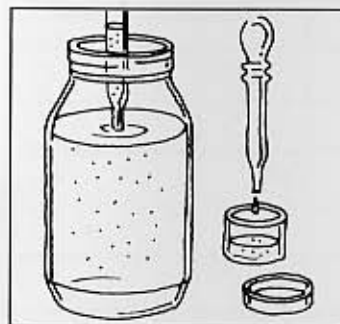

After the brine shrimp have hatched, you may use the shrimp hatchery jar included in your kit to raise the shrimp and observe them. To do this, remove the young shrimp with the dropper and transfer them to the hatchery jar. Feed them as described on page 19.

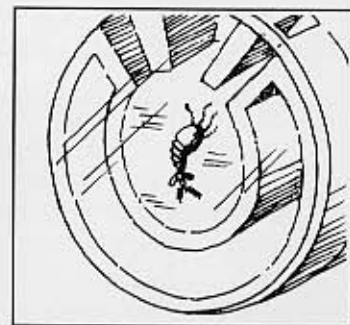

When you want to observe the shrimp, hold the Deluxe MagniScope above the hatchery or use the microaquarium method.

# Soil and Water Creatures

## Soil Creatures

There are thousands of different types of interesting creatures living in soil. The following activity will introduce you to some of them.



## Try This

Use your tweezers or a small spoon to take a small sample of soil from different places around your home. Some places to try are vegetable gardens, flower gardens, flowerpots, grassy or lawn areas, vacant lots, muddy areas, compost piles, tree litter, and farmland. Observe the soil using the slide method. Remember to add a drop of water to your sample. Put your observations in the Soil Creature Observation Table. Be sure to wash your hands after handling soil samples.

### You Will Need:

- tweezers or small spoon
- slide
- coverslip
- dropper
- microaquarium

## Soil Creature Observation Table

Where the Soil Came From	Observations and Drawings	Creatures' Names

## Water Creatures

There are also thousands of different types of fascinating creatures living in water. Use your dropper to take a very small sample of water from different places. Some places to get samples are puddles, streams, rivers, bogs, marshes, lakes, tide pools, water fountains, and drainage ditches. Observe these samples using the slide method or microaquarium method. Put your observations in the Water Creature Observation Table. Be sure to wash your hands after handling the water samples.



## Water Creature Observation Table

Where the Water Came From	Observations and Drawings	Creatures' Names

After gathering and observing your samples, try to identify the creatures you found. Use the pictures on the next page or a field guide. Field guides can be found in libraries and bookstores. Add the names of the creatures you identified to the last column of the Observation Tables.

## Some Common Soil and Water Creatures



Daphnia

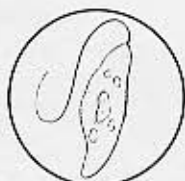

Euglena



Tubifex



Copepod



Mosquito



Mosquito Larva



Roundworm



Rotifer

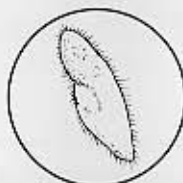

Paramecium



Planarian



Amoeba



Water Mite

## CARE OF THE DELUXE MAGNISCOPE



To clean the eye lens when it gets dirty, first pop off the rubber eye cup, then gently blow off the dirt particles.

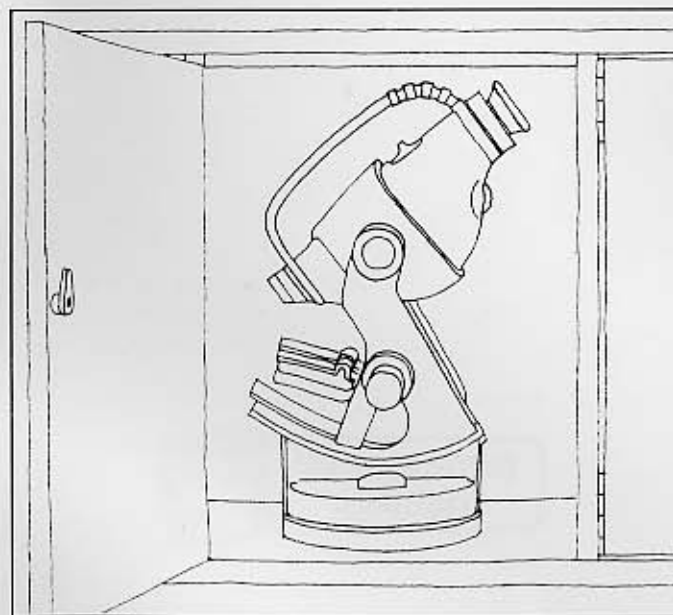

Store your Deluxe MagniScope in a dry place. Moisture can cause mold to grow on the lenses and impair viewing.