

GEO SAFARI®

ELECTRONIC LEARNING GAME

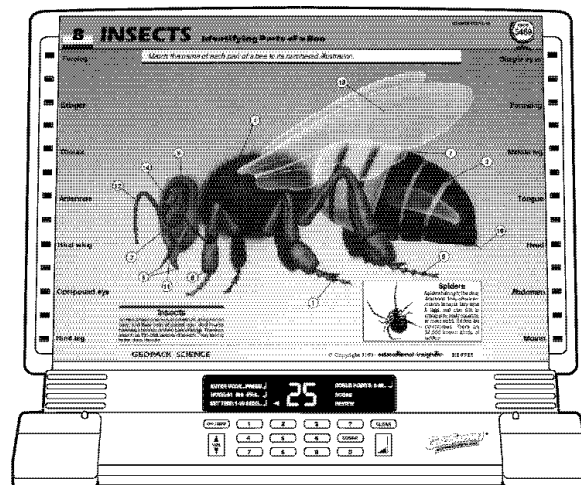

Instruction Guide

WARNING: Adapters not designed for the GeoSafari can cause permanent damage to the machine's electronics. Use of any adapter other than the adapter especially designed for GeoSafari **will void your warranty.**

Table of Contents

| | |
|--|----|
| OPERATING YOUR GEOSAFARI MACHINE | 4 |
| LET'S LOOK AT GEOSAFARI | 6 |
| USING YOUR GEOSAFARI | 8 |
| Single-Player Mode (Mode 1) | 8 |
| Entering the Code | |
| Choosing the Mode | |
| Setting the Response Time | |
| Starting Play | |
| Scoring a Game | |
| Ending a Game | |
| Review Option | |
| Starting a New Game | |
| Two-Player Alternating Mode (Mode 2) | 10 |
| Entering the Code | |
| Choosing the Mode | |
| Setting the Response Times | |
| Setting Bonus Points | |
| Starting Play | |
| Scoring a Game | |
| Ending a Game | |
| Starting a New Game | |
| For Two Players in the Head-to-Head Mode (Mode 3) ... | 12 |
| Entering the Code | |
| Choosing the Mode | |
| Setting the Response Times | |
| Setting Bonus Points | |
| Starting Play | |
| Scoring a Game | |
| Ending a Game | |
| Starting a New Game | |
| Preview Modes | 14 |
| MAKING YOUR OWN GEOSAFARI CARDS | 15 |
| Using Matching Answer Codes | 16 |
| Using Two-Choice Answer Codes | 18 |
| Using Four-Choice Answer Codes | 20 |
| If Your GeoSafari Fails to Operate Properly | 22 |

Operating Your GeoSafari Machine

GeoSafari machines are packed with features that will help you learn and retain geography facts and other useful information. With this guide you can make the most of GeoSafari's many features.

Operating the machine with batteries

For the best operation, always use fresh alkaline batteries.

1. Carefully open the battery compartment door located on the back of your machine.
2. Install four fresh D-cell (DC 1.5 V ) batteries in the battery compartment, as shown.
 - Batteries must be inserted with the correct polarity.
 - Do not mix old and new batteries. Do not mix alkaline, standard (carbon-zinc), or rechargeable (nickel-cadmium) batteries.
 - Remove exhausted batteries from the machine.
 - The supply terminals must not be short circuited.
 - Non-rechargeable batteries must not be recharged.
3. Close the compartment door.
4. Turn on your machine.
5. Do not use rechargeable batteries.

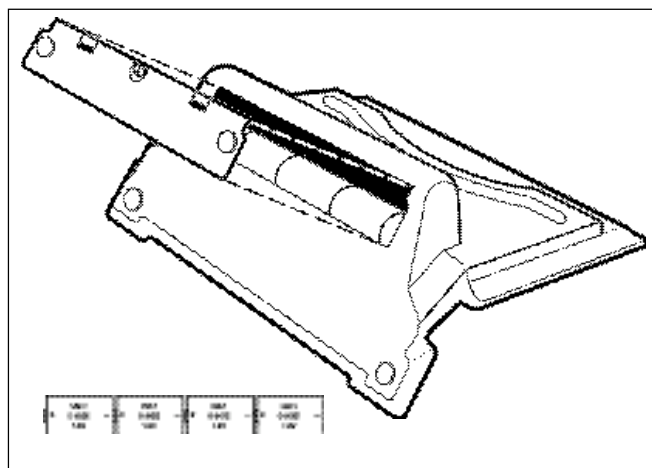

Operating the machine with the adapter

With the optional AC Adapter* the machine can run indefinitely without batteries. To use a machine with its adapter:

1. Plug the end of the adapter cord into the AC adapter jack on the back of the machine.
 - Your GeoSafari machine must only be used with the recommended AC adapter.
 - Your AC adapter should be regularly examined for damage to the cord, plug, enclosure, and other parts. In the event of such damage, do not use this AC adapter until the damage has been repaired.
 - Your AC adapter must comply with CEE Publication 15.
2. Carefully plug the adapter body into an electric outlet.
 - Your GeoSafari machine must not be connected to more than the recommended number of power supplies.
 - Your GeoSafari machine is not suitable for children under three (3) years old.
3. Turn on your machine.

* Especially designed for GeoSafari

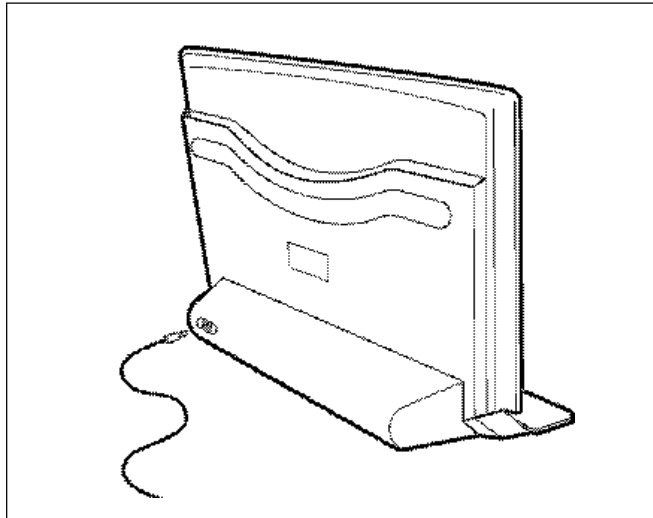

Let's Look at GeoSafari

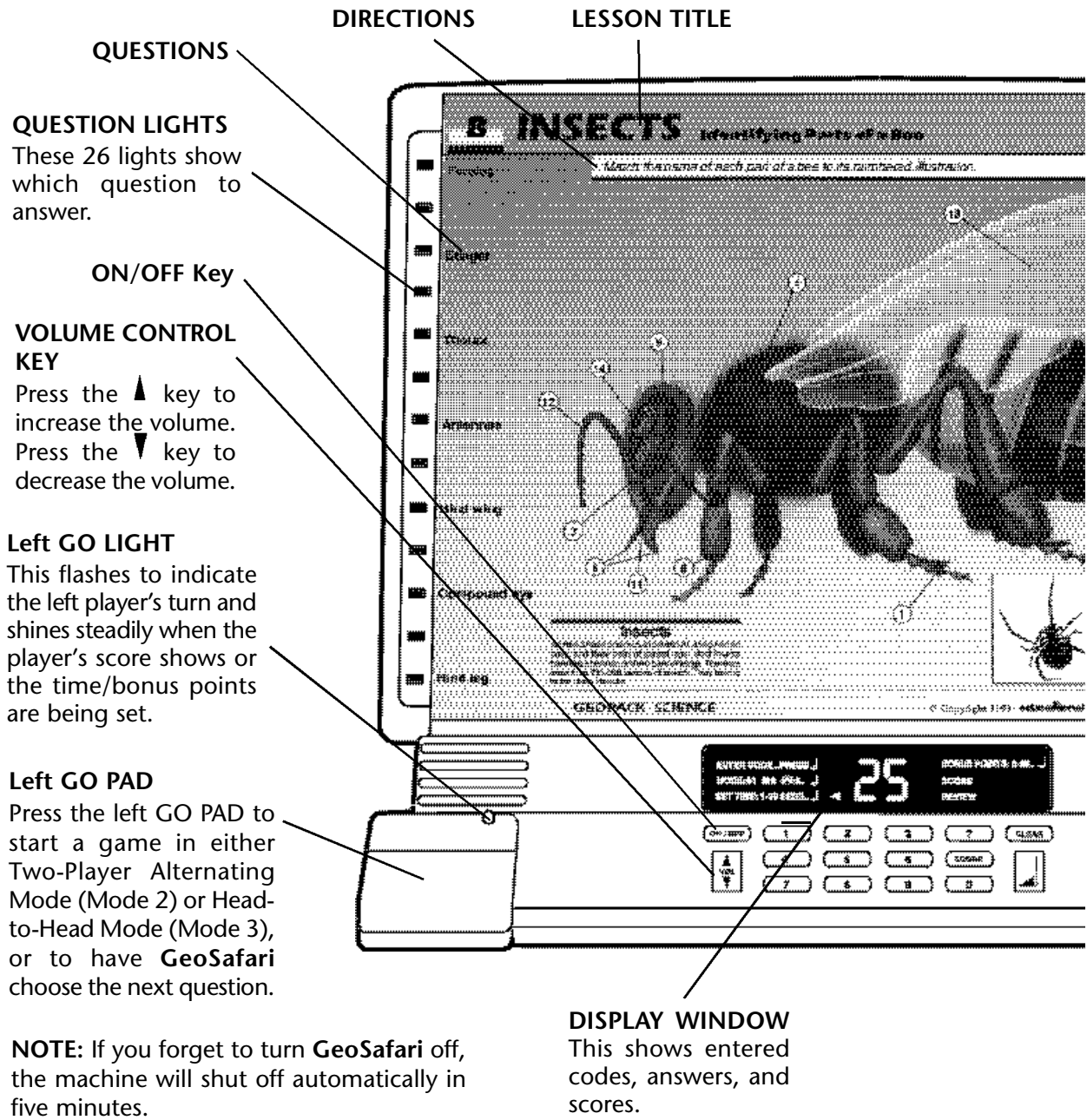

QUESTIONS

QUESTION LIGHTS
These 26 lights show which question to answer.

ON/OFF Key

VOLUME CONTROL KEY
Press the ▲ key to increase the volume. Press the ▼ key to decrease the volume.

Left GO LIGHT
This flashes to indicate the left player's turn and shines steadily when the player's score shows or the time/bonus points are being set.

Left GO PAD
Press the left GO PAD to start a game in either Two-Player Alternating Mode (Mode 2) or Head-to-Head Mode (Mode 3), or to have GeoSafari choose the next question.

NOTE: If you forget to turn GeoSafari off, the machine will shut off automatically in five minutes.

DIRECTIONS

LESSON TITLE

DISPLAY WINDOW
This shows entered codes, answers, and scores.

QUESTION TITLE

CODE

SCORE

Press this key during a game between questions to have the scores displayed.

CLEAR

Press this key once if you type a wrong answer and would like to change it before pressing ↵. To end the game and begin a new one, press CLEAR twice.

Right GO LIGHT

This flashes to indicate the right player's turn and shines steadily when the player's score shows or the time/bonus points are being set.

Right GO PAD

Press the right GO PAD to start a game in either One-Player Mode (Mode 1) or Head-to-Head Mode (Mode 3), or to have GeoSafari choose the next question.

FUNCTION KEYS

Press this key after selecting numbers, answers, or codes.

?

Press this key to reveal the correct answer or to change the second response time in the Head-to-Head Mode (Mode 3).

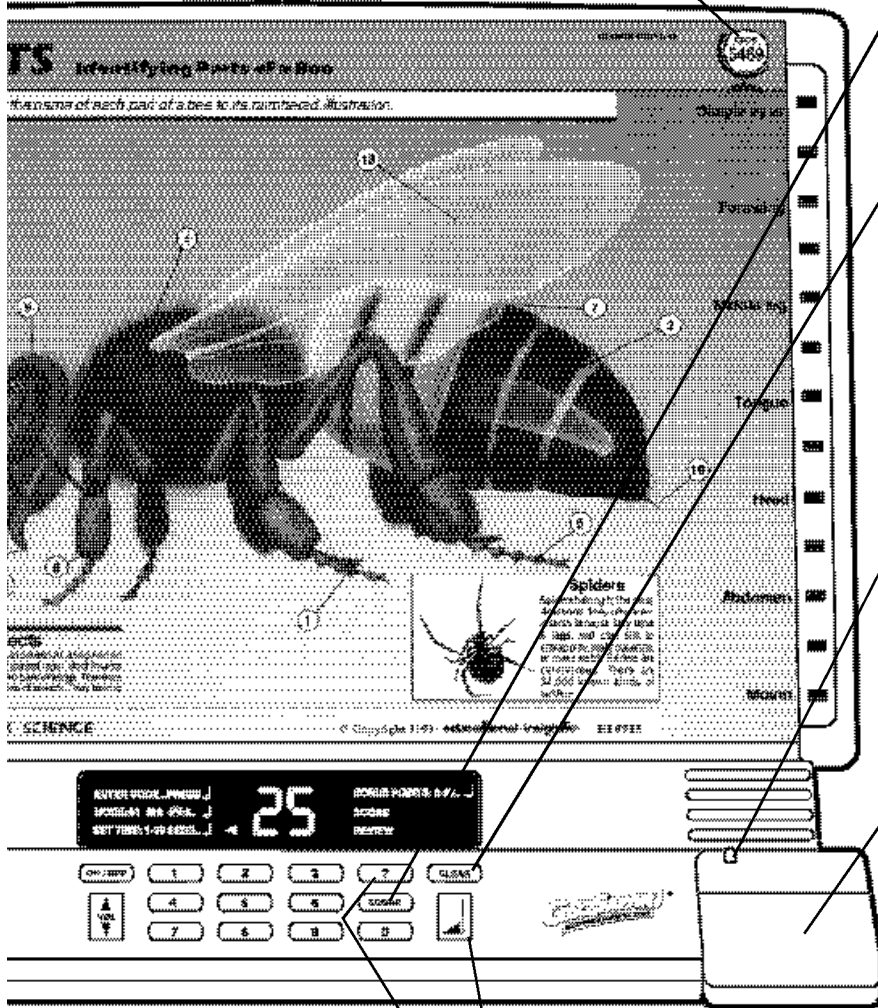

Using Your GeoSafari®

Choose a card to work on, and place it on the machine. Turn **GeoSafari** on by pressing the **ON/OFF** key. Pressing this key again will turn the machine off. The display reads **HI**. Follow the instructions below:

SINGLE-PLAYER MODE (Mode 1)

Entering the Code: The arrow will flash next to **ENTER CODE**.

Type in the lesson's four-digit code located in the upper right-hand corner of the card. Press ↵. The machine will sound an error if the code is not entered correctly.

Choosing the Mode: The arrow will flash next to **MODE**. Press ↵,

and the machine will automatically go into the Single-Player Mode (Mode 1).

Setting the Response Time: The arrow will flash next to **SET**

TIME and 20 will show in the display. If ↵ is pressed again, the response time will be 20 seconds. To select a different response time, type in the new time and press ↵. **GeoSafari** will accept times from 1 to 99 seconds. The right **GO LIGHT** will flash.

Starting Play: Always read the directions near the top of the

card before you answer any questions. To start, press the right **GO PAD** when the right **GO LIGHT** flashes. The question lights will flash in random order, then stop at a question.

1. Read the question next to the flashing light.
2. Enter your answer by pressing the appropriate number key(s) and press ↵. **GeoSafari** will make a ticking sound when you have 5 seconds left to answer the question. If you wish to change an answer at any time before pressing ↵, press **CLEAR**, re-enter your answer, and press ↵. If your answer is correct, you will hear a musical salute! If your answer is incorrect, you will hear an error tone. You then have two more chances to answer the question within the remainder of the response time selected. If your answers are still incorrect after three tries, the correct answer will appear

in the display window. If you do not answer within the response time, you will hear an error tone and the correct answer will appear in the display window.

3. Press the right GO PAD to see the next question.

Scoring a Game: If you answer correctly on the first try, you receive 3 points. If you're correct on the second try, you receive 2 points. If your third answer is correct, you receive 1 point. Scores can be seen by pressing the SCORE key between questions. The right GO LIGHT will shine and the player's score will appear in the display window.

Ending a Game: The game is over when all the questions in the lesson have been presented, and you have heard the ending musical salute. The score will appear in the display window. The total score available depends on the number of questions on the card.

Review Option: At the end of a Mode 1 game, a red light flashes next to each question answered incorrectly, and the arrow flashes next to SCORE and REVIEW in the Display Window. If you press the GO PAD, questions that were missed will be selected, and you will have one chance to answer each correctly. The score will not be changed by getting questions right during the review. The review will continue until all missed questions have been answered correctly, or until CLEAR is pressed twice. This Review Option is only available in Mode 1.

Starting a New Game: The same lesson can be replayed with the same programming. Press CLEAR twice and then press the right GO PAD when the arrow flashes next to ENTER CODE in the display window.

To play a different lesson, remove the original card and place another lesson on the machine. Press CLEAR twice, and enter the code. If the same number of players and response times are used, simply press the right GO PAD. Otherwise enter a new player mode and response time at the arrow prompts. When the right GO LIGHT flashes, press the right GO PAD to start the game.

TWO-PLAYER ALTERNATING MODE (Mode 2)

Entering the Code: The arrow will flash next to ENTER CODE. Type in the lesson's four-digit code located in the upper right-hand corner of the card. Press ↵.

Choosing the Mode: When the arrow flashes next to MODE, type the number 2 and press ↵.

Setting the Response Times: The arrow will flash next to SET TIME, 20 will show in the display, and the left player's GO LIGHT will shine. If the player presses ↵, the response time will be 20 seconds. To select a different response time, type in the new time and press ↵. Then the right player's GO LIGHT will shine. The right player can either press ↵ for the 20 second response time, or type in a new time and press ↵.

After the SET TIME has been entered, the left GO LIGHT will flash. The left player may start the game by pressing the left GO PAD, or can set bonus points at this time.

Setting Bonus Points: If the players decide that one player has more experience or expertise in the lesson subject than the other, they can assign bonus points to make the game more competitive. Bonus points may be entered when two players are playing in Modes 2 and 3. **GeoSafari** will accept numbers from 1 to 20, with a limit of 20 points per player.

After setting the response times, the left GO LIGHT flashes. The left player should press ↵ to set bonus points. The left GO LIGHT will stop flashing and remain on. The arrow next to BONUS POINTS will flash and 0 will appear in the display window. The player on the left will then enter the desired bonus points and press ↵.

The arrow next to BONUS POINTS will flash again, 0 will show in the display window, and the right GO LIGHT will shine. The player on the right can then enter the desired bonus points and press ↵. Either player can choose not to enter bonus points by simply pressing ↵. Once both players complete their entries, the left GO LIGHT will flash, signaling that the game can now be started.

Starting Play: Always read the directions near the top of the card before you start the game. When the light on the left GO PAD flashes, the left player presses the left GO PAD. The question lights will flash in random order, then stop at a question.

1. Read the question next to the flashing light.
2. Enter your answer by pressing the appropriate number key(s) and press ↵.

If you wish to change an answer at any time before pressing ↵, press the CLEAR key, re-enter your answer, and press ↵. **GeoSafari** will make a ticking sound when you have 5 seconds left to answer the question.

If your answer is correct you will hear a musical salute! If your answer is incorrect, you will hear an error tone. You then have two more chances to answer the question within the remainder of response time selected. If your answers are still incorrect after all three tries, the correct answer will appear in the display window.

3. Players' turns alternate with each question. The GO LIGHT always shows which player should answer the question. A special musical tone will indicate that it is the next player's turn.

Scoring a Game: Scores can be seen by pressing the SCORE key between questions. With two players, the left GO LIGHT will shine and the left player's score will show in the display window. Then the right player's GO LIGHT will shine, and the right player's score will appear in the display window. The scores will include bonus points, if bonus points have been entered at the beginning of the game. A flashing GO LIGHT will come on automatically after the SCORE display to indicate the next player's turn.

If you answer correctly on the first try, you receive 3 points. If you're correct on the second try, you receive 2 points, and if your third answer is correct, you receive 1 point. The total score that can be obtained by players depends on the number of questions on the card and whether or not bonus points have been entered.

Ending a Game: The game is over when all the questions in the lesson have been presented, and you have heard the ending musical salute. At the end of the game, **GeoSafari** displays the left player's score and flashing red lights by questions missed, and then the right player's score is displayed with flashing red lights by questions missed.

Starting a New Game: The same lesson can be replayed with the same programming by pressing CLEAR twice, then pressing the left GO PAD when the arrow flashes next to ENTER CODE.

To play a different lesson, remove the original card and place another lesson card on the machine. Press CLEAR twice, and enter the code. If the same number of players, response times, and bonus points are used, press the left GO PAD. Otherwise, enter a new player mode, response times, and bonus points at the arrow prompts. When the left GO LIGHT flashes, the left player will press the left GO PAD.

FOR TWO PLAYERS IN THE HEAD-TO-HEAD MODE (Mode 3)

The Head-to-Head mode adds excitement to the contest between two players because questions may be answered by either player.

Entering the Code: The arrow will flash next to ENTER CODE. Type in the lesson's four-digit code located in the upper right-hand corner of the card. Press ↵.

Choosing the Mode: To play a game in the Head-to-Head mode, press 3 at the prompt for MODE and ↵.

Setting Response Times: The arrow will flash next to SET TIME and 20 will show in the display. You can now set response times. In the Head-to-Head mode there are two response times. The **first** response time is the time allotted for either player to press his/her GO PAD in order to answer the question. When the arrow flashes next to SET TIME and 20 shows in the display, the machine will use the default time of 20 seconds, automatically, if ↵ is pressed. To select a different time setting, type in the new time and press ↵. **GeoSafari** will accept times from 1 to 99 seconds. The response time entered will apply to both players.

After entering the **first** response time, the GO LIGHTS will flash. You can now start the game or set the **second** response time. The **second** response time, or the answer time, is the time allotted after the GO PAD is pressed to type in the answer and press ↵. The default time is 5 seconds for both players and can only be changed by pressing the ? key **before** pressing a GO PAD and starting a game.

Once the ? key is pressed, 5 will appear in the display window and SET TIME will flash. At this time, players may enter a new answer time, which will apply to both players, by pressing the number and ↵. Both GO LIGHTS will flash. Either player may press either GO PAD to start play, or press ↵ to set bonus points.

Setting Bonus Points: Bonus points may be entered when two players are playing in Modes 2 and 3. **GeoSafari** will accept numbers from 1 to 20, with a limit of 20 points per player. After setting the response times, the left GO LIGHT flashes. The left player should press ↵ to set bonus points. The left GO LIGHT will stop flashing and will shine. The arrow next to BONUS POINTS will flash and 0 will appear in the display window. The player on the left will then enter the desired bonus points and press ↵.

The arrow next to BONUS POINTS will flash again, 0 will appear in the display window, and the right GO LIGHT will shine. The player

on the right can then enter the desired bonus points and press ↵. Either player can choose not to enter bonus points simply by pressing ↵. Once both players complete their entries, both GO LIGHTS will flash, indicating that the game can now be started.

Starting Play: Once all choices have been entered, both GO LIGHTS will flash. Press either GO PAD to start the game. When the question lights stop at a question, both players have the time set for the **first** response time to press his/her GO PAD. The first player to press his/her GO PAD gets to answer first. When the first player presses his/her GO PAD, a series of musical notes will sound and the GO LIGHT for that player will shine.

The first player then has the answer time, or **second** time limit that was set, to enter an answer and press ↵. **GeoSafari** will make a ticking sound when the player has 5 seconds left to answer the question. If the answer is correct, the first player earns 3 points. Both player lights then flash, and either player can press either GO PAD to go on to the next question.

Scoring a Game: If the first player's answer is wrong, a point is subtracted from the score of that player. **GeoSafari** will make a whooping sound, straight lines will flash in the display area, and the second player's GO LIGHT will shine. This alerts the second player that he/she now has a chance to answer the question. To answer the question, the second player will enter his/her answer and press ↵. If the question is answered correctly in the available time, the second player receives 2 points. If the second player answers incorrectly, that player also has a point subtracted from his/her score. If the second player decides not to answer the question, he/she should make no response, and his/her score will remain the same.

If neither GO PAD is pressed before the **first** response time is up, the machine will make a nonmusical sound, the answer will show on the screen, and both player lights will flash slowly. If a long **first** response time has been entered and neither player wants to answer a question, the game may be sped up by either player pressing the ? key. If neither player wants to answer the question, the score remains the same. The answer will show on the screen and both player lights will flash. This signals that either player may press either GO PAD to select another question.

Ending a Game: The game is over when all the questions in the lesson have been presented and you have heard the ending musical salute. At the end of the game, **GeoSafari** displays the left player's score and flashing red lights by questions missed, and then the right player's score is displayed with flashing red lights by questions missed. The

player's GO LIGHT shines when his/her score is being displayed.

Starting a New Game: The same lesson can be replayed with the same programming by pressing CLEAR twice, then the GO PAD when the arrow flashes next to ENTER CODE.

To play a different lesson, remove the original card and place another lesson card on the machine. Press CLEAR twice, and enter the code. If the same number of players, response times and bonus points are used, simply press either GO PAD. Otherwise, enter a new player mode, response times, and bonus points at the arrow prompts. When a player light flashes, press the related GO PAD.

PREVIEW MODES

Answer Preview: Some **GeoSafari** lessons are more difficult than others. Whenever you encounter a new or difficult lesson, you can preview the answers.

To preview the answers to any lesson, begin the game as usual by pressing the GO PAD, then simply press the ? key each time the machine asks a question. Take all the time you need to study each answer. You may move on to the next question by pressing the GO PAD. To return to normal play, press the CLEAR key twice and then press the GO PAD.

Quick Preview: To quickly preview all of the questions on a lesson card, turn **GeoSafari** off, then on. Type in the lesson code and hold down the ↵ key for three seconds. **GeoSafari** will automatically and randomly choose each question on the card. The answer will appear briefly in the display window before a new question is reviewed. To stop Quick Preview, turn the machine off, then on.

Sequential Preview: To preview the answers on a lesson card in order, turn **GeoSafari** off. Hold down the 7, 8, and 9 keys and press the ON/OFF key at the same time. The display will read HI, and the arrow will flash next to ENTER CODE. Type in the lesson's four-digit code located in the upper right-hand corner of the card and press ↵. The top left question light will shine, the correct answer will be in the display, and the right GO LIGHT will flash. Take all the time you need to study this answer. You may move on to the next question by pressing the right GO PAD.

Once you have previewed all the questions on the card, the arrow will flash next to ENTER CODE and the right GO LIGHT will flash. If you wish to continue using the Sequential Preview option, choose another lesson card, enter the lesson code, and press ↵. To leave Sequential Preview, turn the machine off, then on.

Making Your Own GeoSafari Cards

It's easy to make your own GeoSafari cards. Have fun experimenting. You will be amazed at the flexibility of your GeoSafari machine!

Use ready-made lessons as a guide, or be creative and try something completely different. As you get used to making your own lessons, you'll see that the possibilities are endless! Make your new set with as many or as few lessons as you wish, or add extra lessons to sets you already have.

Ideas for sets of your own might include:

| | |
|-------------------|-------------------------------|
| basic math skills | recognizing plants or animals |
| your community | history or art |
| the universe | religion |
| world culture | genealogy or family history |

Step-by-step method

1. Decide which skill you want to teach or review.
2. Draw or cut out an appropriate map, photo, or illustration and mount it onto the middle panel of a blank card. Include only relevant information on the middle panel.
3. Look at your **GeoSafari** machine. There are 13 lights down the left side and 13 lights down the right side of the machine. Each question on a card must line up with one of the lights on the machine. If you ask 26 questions, place a question beside every light. However, if you choose to ask fewer questions, some lights will simply not be used.
4. On page 17, look at the top left panel showing code 2158. This code has only ten questions. Small squares with numbers next to them represent the lights beside which you will place your questions. These numbers represent the correct answers for those questions.

Dashes beside the light symbols represent spaces that will not be used for that code. For code 2158, the answer for the top left-hand question is 1. The second light down has no question beside it . . . and so on.

Decide if you want the answers to your questions to follow a matching, two-choice, or four-choice format. See the following appropriate section for further instructions.

USING MATCHING ANSWER CODES

The matching answer codes are useful when you want to match related pieces of information, such as matching descriptions to names or to numbered pictures. For example, you could match the names of capitals to their locations on a map.

To make cards using a matching format:

1. Decide how many questions you want to ask. **GeoSafari's** built-in codes offer you a choice of 10, 12, 14, 16, 20, or 26 questions.
2. Divide your questions into two groups, one for the left-side panel and one for the right-side panel of the card. On a Make-Your-Own blank card, write each question beside its corresponding question light.
The card shown below has 20 questions, divided into two groups of ten. Notice that the last three lights on both the left and right sides have no questions beside them.
3. Number each illustration in the middle panel to match its question. If you have used code 5086 for example, the first question on the left side should match an illustration you have numbered 13 on the middle panel.

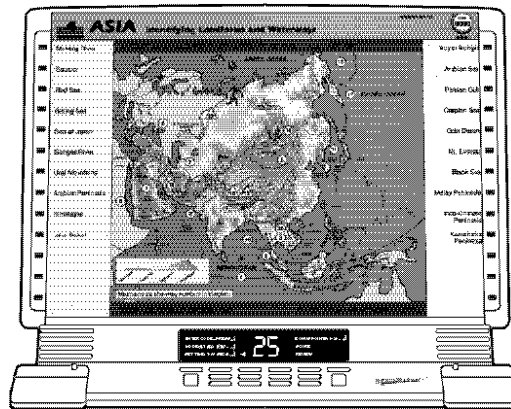

MATCHING ANSWER CODES

The answers for each of the matching answer codes (shown on the next page) are arranged in a pattern similar to the layout of the **GeoSafari** machine. Each small square down the sides represents a light on the machine. Each dash represents a position at which there is no question. Place the corresponding answer numbers on the correct part of the illustration in the middle panel.

Matching Answer Codes

| <p>Matching answers, 10 questions, 30 points</p> <p style="text-align: center;">Code: 2158</p> <table style="width: 100%; border-collapse: collapse;"> <thead> <tr> <th style="text-align: left;">LEFT SIDE LIGHTS</th> <th style="text-align: left;">RIGHT SIDE LIGHTS</th> </tr> </thead> <tbody> <tr><td><input type="checkbox"/> 1</td><td><input type="checkbox"/> 2</td></tr> <tr><td><input type="checkbox"/> -</td><td><input type="checkbox"/> -</td></tr> <tr><td><input type="checkbox"/> 8</td><td><input type="checkbox"/> 3</td></tr> <tr><td><input type="checkbox"/> -</td><td><input type="checkbox"/> -</td></tr> <tr><td><input type="checkbox"/> 7</td><td><input type="checkbox"/> 10</td></tr> <tr><td><input type="checkbox"/> -</td><td><input type="checkbox"/> -</td></tr> <tr><td><input type="checkbox"/> 5</td><td><input type="checkbox"/> 4</td></tr> <tr><td><input type="checkbox"/> -</td><td><input type="checkbox"/> -</td></tr> <tr><td><input type="checkbox"/> 6</td><td><input type="checkbox"/> 9</td></tr> <tr><td><input type="checkbox"/> -</td><td><input type="checkbox"/> -</td></tr> <tr><td><input type="checkbox"/> -</td><td><input type="checkbox"/> -</td></tr> <tr><td><input type="checkbox"/> -</td><td><input type="checkbox"/> -</td></tr> <tr><td><input type="checkbox"/> -</td><td><input type="checkbox"/> -</td></tr> </tbody> </table> | LEFT SIDE LIGHTS | RIGHT SIDE LIGHTS | <input type="checkbox"/> 1 | <input type="checkbox"/> 2 | <input type="checkbox"/> - | <input type="checkbox"/> - | <input type="checkbox"/> 8 | <input type="checkbox"/> 3 | <input type="checkbox"/> - | <input type="checkbox"/> - | <input type="checkbox"/> 7 | <input type="checkbox"/> 10 | <input type="checkbox"/> - | <input type="checkbox"/> - | <input type="checkbox"/> 5 | <input type="checkbox"/> 4 | <input type="checkbox"/> - | <input type="checkbox"/> - | <input type="checkbox"/> 6 | <input type="checkbox"/> 9 | <input type="checkbox"/> - | <input type="checkbox"/> - | <input type="checkbox"/> - | <input type="checkbox"/> - | <input type="checkbox"/> - | <input type="checkbox"/> - | <input type="checkbox"/> - | <input type="checkbox"/> - | <p>Matching answers, 10 questions, 30 points</p> <p style="text-align: center;">Code: 2012</p> <table style="width: 100%; border-collapse: collapse;"> <thead> <tr> <th style="text-align: left;">LEFT SIDE LIGHTS</th> <th style="text-align: left;">RIGHT SIDE LIGHTS</th> </tr> </thead> <tbody> <tr><td><input type="checkbox"/> 2</td><td><input type="checkbox"/> 10</td></tr> <tr><td><input type="checkbox"/> -</td><td><input type="checkbox"/> -</td></tr> <tr><td><input type="checkbox"/> 1</td><td><input type="checkbox"/> 8</td></tr> <tr><td><input type="checkbox"/> -</td><td><input type="checkbox"/> -</td></tr> <tr><td><input type="checkbox"/> 5</td><td><input type="checkbox"/> 4</td></tr> <tr><td><input type="checkbox"/> -</td><td><input type="checkbox"/> -</td></tr> <tr><td><input type="checkbox"/> 6</td><td><input type="checkbox"/> 3</td></tr> <tr><td><input type="checkbox"/> -</td><td><input type="checkbox"/> -</td></tr> <tr><td><input type="checkbox"/> 7</td><td><input type="checkbox"/> 9</td></tr> <tr><td><input type="checkbox"/> -</td><td><input type="checkbox"/> -</td></tr> <tr><td><input type="checkbox"/> -</td><td><input type="checkbox"/> -</td></tr> <tr><td><input type="checkbox"/> -</td><td><input type="checkbox"/> -</td></tr> <tr><td><input type="checkbox"/> -</td><td><input type="checkbox"/> -</td></tr> </tbody> </table> | LEFT SIDE LIGHTS | RIGHT SIDE LIGHTS | <input type="checkbox"/> 2 | <input type="checkbox"/> 10 | <input type="checkbox"/> - | <input type="checkbox"/> - | <input type="checkbox"/> 1 | <input type="checkbox"/> 8 | <input type="checkbox"/> - | <input type="checkbox"/> - | <input type="checkbox"/> 5 | <input type="checkbox"/> 4 | <input type="checkbox"/> - | <input type="checkbox"/> - | <input type="checkbox"/> 6 | <input type="checkbox"/> 3 | <input type="checkbox"/> - | <input type="checkbox"/> - | <input type="checkbox"/> 7 | <input type="checkbox"/> 9 | <input type="checkbox"/> - | <input type="checkbox"/> - | <input type="checkbox"/> - | <input type="checkbox"/> - | <input type="checkbox"/> - | <input type="checkbox"/> - | <input type="checkbox"/> - | <input type="checkbox"/> - | <p>Matching answers, 12 questions, 36 points</p> <p style="text-align: center;">Code: 3783</p> <table style="width: 100%; border-collapse: collapse;"> <thead> <tr> <th style="text-align: left;">LEFT SIDE LIGHTS</th> <th style="text-align: left;">RIGHT SIDE LIGHTS</th> </tr> </thead> <tbody> <tr><td><input type="checkbox"/> 1</td><td><input type="checkbox"/> 8</td></tr> <tr><td><input type="checkbox"/> -</td><td><input type="checkbox"/> -</td></tr> <tr><td><input type="checkbox"/> 2</td><td><input type="checkbox"/> 4</td></tr> <tr><td><input type="checkbox"/> -</td><td><input type="checkbox"/> -</td></tr> <tr><td><input type="checkbox"/> 10</td><td><input type="checkbox"/> 5</td></tr> <tr><td><input type="checkbox"/> -</td><td><input type="checkbox"/> -</td></tr> <tr><td><input type="checkbox"/> 11</td><td><input type="checkbox"/> 12</td></tr> <tr><td><input type="checkbox"/> -</td><td><input type="checkbox"/> -</td></tr> <tr><td><input type="checkbox"/> 3</td><td><input type="checkbox"/> 6</td></tr> <tr><td><input type="checkbox"/> -</td><td><input type="checkbox"/> -</td></tr> <tr><td><input type="checkbox"/> 7</td><td><input type="checkbox"/> 9</td></tr> <tr><td><input type="checkbox"/> -</td><td><input type="checkbox"/> -</td></tr> <tr><td><input type="checkbox"/> -</td><td><input type="checkbox"/> -</td></tr> </tbody> </table> | LEFT SIDE LIGHTS | RIGHT SIDE LIGHTS | <input type="checkbox"/> 1 | <input type="checkbox"/> 8 | <input type="checkbox"/> - | <input type="checkbox"/> - | <input type="checkbox"/> 2 | <input type="checkbox"/> 4 | <input type="checkbox"/> - | <input type="checkbox"/> - | <input type="checkbox"/> 10 | <input type="checkbox"/> 5 | <input type="checkbox"/> - | <input type="checkbox"/> - | <input type="checkbox"/> 11 | <input type="checkbox"/> 12 | <input type="checkbox"/> - | <input type="checkbox"/> - | <input type="checkbox"/> 3 | <input type="checkbox"/> 6 | <input type="checkbox"/> - | <input type="checkbox"/> - | <input type="checkbox"/> 7 | <input type="checkbox"/> 9 | <input type="checkbox"/> - | <input type="checkbox"/> - | <input type="checkbox"/> - | <input type="checkbox"/> - | <p>Matching answers, 12 questions, 36 points</p> <p style="text-align: center;">Code: 3505</p> <table style="width: 100%; border-collapse: collapse;"> <thead> <tr> <th style="text-align: left;">LEFT SIDE LIGHTS</th> <th style="text-align: left;">RIGHT SIDE LIGHTS</th> </tr> </thead> <tbody> <tr><td><input type="checkbox"/> 11</td><td><input type="checkbox"/> 12</td></tr> <tr><td><input type="checkbox"/> -</td><td><input type="checkbox"/> -</td></tr> <tr><td><input type="checkbox"/> 1</td><td><input type="checkbox"/> 9</td></tr> <tr><td><input type="checkbox"/> -</td><td><input type="checkbox"/> -</td></tr> <tr><td><input type="checkbox"/> 6</td><td><input type="checkbox"/> 3</td></tr> <tr><td><input type="checkbox"/> -</td><td><input type="checkbox"/> -</td></tr> <tr><td><input type="checkbox"/> 4</td><td><input type="checkbox"/> 7</td></tr> <tr><td><input type="checkbox"/> -</td><td><input type="checkbox"/> -</td></tr> <tr><td><input type="checkbox"/> 2</td><td><input type="checkbox"/> 10</td></tr> <tr><td><input type="checkbox"/> -</td><td><input type="checkbox"/> -</td></tr> <tr><td><input type="checkbox"/> 8</td><td><input type="checkbox"/> 5</td></tr> <tr><td><input type="checkbox"/> -</td><td><input type="checkbox"/> -</td></tr> <tr><td><input type="checkbox"/> -</td><td><input type="checkbox"/> -</td></tr> </tbody> </table> | LEFT SIDE LIGHTS | RIGHT SIDE LIGHTS | <input type="checkbox"/> 11 | <input type="checkbox"/> 12 | <input type="checkbox"/> - | <input type="checkbox"/> - | <input type="checkbox"/> 1 | <input type="checkbox"/> 9 | <input type="checkbox"/> - | <input type="checkbox"/> - | <input type="checkbox"/> 6 | <input type="checkbox"/> 3 | <input type="checkbox"/> - | <input type="checkbox"/> - | <input type="checkbox"/> 4 | <input type="checkbox"/> 7 | <input type="checkbox"/> - | <input type="checkbox"/> - | <input type="checkbox"/> 2 | <input type="checkbox"/> 10 | <input type="checkbox"/> - | <input type="checkbox"/> - | <input type="checkbox"/> 8 | <input type="checkbox"/> 5 | <input type="checkbox"/> - | <input type="checkbox"/> - | <input type="checkbox"/> - | <input type="checkbox"/> - | | | | |
|---|-----------------------------|-------------------------|-----------------------------|-----------------------------|-----------------------------|----------------------------|----------------------------|-----------------------------|-----------------------------|-----------------------------|-----------------------------|-----------------------------|----------------------------|----------------------------|-----------------------------|-----------------------------|-----------------------------|----------------------------|-----------------------------|-----------------------------|-----------------------------|----------------------------|----------------------------|-----------------------------|----------------------------|----------------------------|----------------------------|-----------------------------|---|------------------------|-------------------------|----------------------------|-----------------------------|-----------------------------|-----------------------------|-----------------------------|----------------------------|----------------------------|----------------------------|----------------------------|-----------------------------|-----------------------------|----------------------------|-----------------------------|-----------------------------|-----------------------------|----------------------------|-----------------------------|-----------------------------|-----------------------------|-----------------------------|-----------------------------|----------------------------|----------------------------|----------------------------|----------------------------|----------------------------|---|------------------------|-------------------------|----------------------------|-----------------------------|-----------------------------|----------------------------|----------------------------|-----------------------------|-----------------------------|-----------------------------|-----------------------------|-----------------------------|-----------------------------|-----------------------------|-----------------------------|-----------------------------|-----------------------------|-----------------------------|-----------------------------|-----------------------------|-----------------------------|-----------------------------|----------------------------|-----------------------------|-----------------------------|----------------------------|-----------------------------|-----------------------------|---|----------------------------|---|-----------------------------|-----------------------------|-----------------------------|-----------------------------|-----------------------------|-----------------------------|-----------------------------|-----------------------------|-----------------------------|-----------------------------|----------------------------|-----------------------------|----------------------------|----------------------------|-----------------------------|-----------------------------|-----------------------------|-----------------------------|-----------------------------|-----------------------------|-----------------------------|-----------------------------|----------------------------|-----------------------------|-----------------------------|-----------------------------|----------------------------|----------------------------|----------------------------|----------------------------|
| LEFT SIDE LIGHTS | RIGHT SIDE LIGHTS | | | | | | | | | | | | | | | | | | | | | | | | | | | | | | | | | | | | | | | | | | | | | | | | | | | | | | | | | | | | | | | | | | | | | | | | | | | | | | | | | | | | | | | | | | | | | | | | | | | | | | | | | | | | | | | | | | | | | | |
| <input type="checkbox"/> 1 | <input type="checkbox"/> 2 | | | | | | | | | | | | | | | | | | | | | | | | | | | | | | | | | | | | | | | | | | | | | | | | | | | | | | | | | | | | | | | | | | | | | | | | | | | | | | | | | | | | | | | | | | | | | | | | | | | | | | | | | | | | | | | | | | | | | | |
| <input type="checkbox"/> - | <input type="checkbox"/> - | | | | | | | | | | | | | | | | | | | | | | | | | | | | | | | | | | | | | | | | | | | | | | | | | | | | | | | | | | | | | | | | | | | | | | | | | | | | | | | | | | | | | | | | | | | | | | | | | | | | | | | | | | | | | | | | | | | | | | |
| <input type="checkbox"/> 8 | <input type="checkbox"/> 3 | | | | | | | | | | | | | | | | | | | | | | | | | | | | | | | | | | | | | | | | | | | | | | | | | | | | | | | | | | | | | | | | | | | | | | | | | | | | | | | | | | | | | | | | | | | | | | | | | | | | | | | | | | | | | | | | | | | | | | |
| <input type="checkbox"/> - | <input type="checkbox"/> - | | | | | | | | | | | | | | | | | | | | | | | | | | | | | | | | | | | | | | | | | | | | | | | | | | | | | | | | | | | | | | | | | | | | | | | | | | | | | | | | | | | | | | | | | | | | | | | | | | | | | | | | | | | | | | | | | | | | | | |
| <input type="checkbox"/> 7 | <input type="checkbox"/> 10 | | | | | | | | | | | | | | | | | | | | | | | | | | | | | | | | | | | | | | | | | | | | | | | | | | | | | | | | | | | | | | | | | | | | | | | | | | | | | | | | | | | | | | | | | | | | | | | | | | | | | | | | | | | | | | | | | | | | | | |
| <input type="checkbox"/> - | <input type="checkbox"/> - | | | | | | | | | | | | | | | | | | | | | | | | | | | | | | | | | | | | | | | | | | | | | | | | | | | | | | | | | | | | | | | | | | | | | | | | | | | | | | | | | | | | | | | | | | | | | | | | | | | | | | | | | | | | | | | | | | | | | | |
| <input type="checkbox"/> 5 | <input type="checkbox"/> 4 | | | | | | | | | | | | | | | | | | | | | | | | | | | | | | | | | | | | | | | | | | | | | | | | | | | | | | | | | | | | | | | | | | | | | | | | | | | | | | | | | | | | | | | | | | | | | | | | | | | | | | | | | | | | | | | | | | | | | | |
| <input type="checkbox"/> - | <input type="checkbox"/> - | | | | | | | | | | | | | | | | | | | | | | | | | | | | | | | | | | | | | | | | | | | | | | | | | | | | | | | | | | | | | | | | | | | | | | | | | | | | | | | | | | | | | | | | | | | | | | | | | | | | | | | | | | | | | | | | | | | | | | |
| <input type="checkbox"/> 6 | <input type="checkbox"/> 9 | | | | | | | | | | | | | | | | | | | | | | | | | | | | | | | | | | | | | | | | | | | | | | | | | | | | | | | | | | | | | | | | | | | | | | | | | | | | | | | | | | | | | | | | | | | | | | | | | | | | | | | | | | | | | | | | | | | | | | |
| <input type="checkbox"/> - | <input type="checkbox"/> - | | | | | | | | | | | | | | | | | | | | | | | | | | | | | | | | | | | | | | | | | | | | | | | | | | | | | | | | | | | | | | | | | | | | | | | | | | | | | | | | | | | | | | | | | | | | | | | | | | | | | | | | | | | | | | | | | | | | | | |
| <input type="checkbox"/> - | <input type="checkbox"/> - | | | | | | | | | | | | | | | | | | | | | | | | | | | | | | | | | | | | | | | | | | | | | | | | | | | | | | | | | | | | | | | | | | | | | | | | | | | | | | | | | | | | | | | | | | | | | | | | | | | | | | | | | | | | | | | | | | | | | | |
| <input type="checkbox"/> - | <input type="checkbox"/> - | | | | | | | | | | | | | | | | | | | | | | | | | | | | | | | | | | | | | | | | | | | | | | | | | | | | | | | | | | | | | | | | | | | | | | | | | | | | | | | | | | | | | | | | | | | | | | | | | | | | | | | | | | | | | | | | | | | | | | |
| <input type="checkbox"/> - | <input type="checkbox"/> - | | | | | | | | | | | | | | | | | | | | | | | | | | | | | | | | | | | | | | | | | | | | | | | | | | | | | | | | | | | | | | | | | | | | | | | | | | | | | | | | | | | | | | | | | | | | | | | | | | | | | | | | | | | | | | | | | | | | | | |
| LEFT SIDE LIGHTS | RIGHT SIDE LIGHTS | | | | | | | | | | | | | | | | | | | | | | | | | | | | | | | | | | | | | | | | | | | | | | | | | | | | | | | | | | | | | | | | | | | | | | | | | | | | | | | | | | | | | | | | | | | | | | | | | | | | | | | | | | | | | | | | | | | | | | |
| <input type="checkbox"/> 2 | <input type="checkbox"/> 10 | | | | | | | | | | | | | | | | | | | | | | | | | | | | | | | | | | | | | | | | | | | | | | | | | | | | | | | | | | | | | | | | | | | | | | | | | | | | | | | | | | | | | | | | | | | | | | | | | | | | | | | | | | | | | | | | | | | | | | |
| <input type="checkbox"/> - | <input type="checkbox"/> - | | | | | | | | | | | | | | | | | | | | | | | | | | | | | | | | | | | | | | | | | | | | | | | | | | | | | | | | | | | | | | | | | | | | | | | | | | | | | | | | | | | | | | | | | | | | | | | | | | | | | | | | | | | | | | | | | | | | | | |
| <input type="checkbox"/> 1 | <input type="checkbox"/> 8 | | | | | | | | | | | | | | | | | | | | | | | | | | | | | | | | | | | | | | | | | | | | | | | | | | | | | | | | | | | | | | | | | | | | | | | | | | | | | | | | | | | | | | | | | | | | | | | | | | | | | | | | | | | | | | | | | | | | | | |
| <input type="checkbox"/> - | <input type="checkbox"/> - | | | | | | | | | | | | | | | | | | | | | | | | | | | | | | | | | | | | | | | | | | | | | | | | | | | | | | | | | | | | | | | | | | | | | | | | | | | | | | | | | | | | | | | | | | | | | | | | | | | | | | | | | | | | | | | | | | | | | | |
| <input type="checkbox"/> 5 | <input type="checkbox"/> 4 | | | | | | | | | | | | | | | | | | | | | | | | | | | | | | | | | | | | | | | | | | | | | | | | | | | | | | | | | | | | | | | | | | | | | | | | | | | | | | | | | | | | | | | | | | | | | | | | | | | | | | | | | | | | | | | | | | | | | | |
| <input type="checkbox"/> - | <input type="checkbox"/> - | | | | | | | | | | | | | | | | | | | | | | | | | | | | | | | | | | | | | | | | | | | | | | | | | | | | | | | | | | | | | | | | | | | | | | | | | | | | | | | | | | | | | | | | | | | | | | | | | | | | | | | | | | | | | | | | | | | | | | |
| <input type="checkbox"/> 6 | <input type="checkbox"/> 3 | | | | | | | | | | | | | | | | | | | | | | | | | | | | | | | | | | | | | | | | | | | | | | | | | | | | | | | | | | | | | | | | | | | | | | | | | | | | | | | | | | | | | | | | | | | | | | | | | | | | | | | | | | | | | | | | | | | | | | |
| <input type="checkbox"/> - | <input type="checkbox"/> - | | | | | | | | | | | | | | | | | | | | | | | | | | | | | | | | | | | | | | | | | | | | | | | | | | | | | | | | | | | | | | | | | | | | | | | | | | | | | | | | | | | | | | | | | | | | | | | | | | | | | | | | | | | | | | | | | | | | | | |
| <input type="checkbox"/> 7 | <input type="checkbox"/> 9 | | | | | | | | | | | | | | | | | | | | | | | | | | | | | | | | | | | | | | | | | | | | | | | | | | | | | | | | | | | | | | | | | | | | | | | | | | | | | | | | | | | | | | | | | | | | | | | | | | | | | | | | | | | | | | | | | | | | | | |
| <input type="checkbox"/> - | <input type="checkbox"/> - | | | | | | | | | | | | | | | | | | | | | | | | | | | | | | | | | | | | | | | | | | | | | | | | | | | | | | | | | | | | | | | | | | | | | | | | | | | | | | | | | | | | | | | | | | | | | | | | | | | | | | | | | | | | | | | | | | | | | | |
| <input type="checkbox"/> - | <input type="checkbox"/> - | | | | | | | | | | | | | | | | | | | | | | | | | | | | | | | | | | | | | | | | | | | | | | | | | | | | | | | | | | | | | | | | | | | | | | | | | | | | | | | | | | | | | | | | | | | | | | | | | | | | | | | | | | | | | | | | | | | | | | |
| <input type="checkbox"/> - | <input type="checkbox"/> - | | | | | | | | | | | | | | | | | | | | | | | | | | | | | | | | | | | | | | | | | | | | | | | | | | | | | | | | | | | | | | | | | | | | | | | | | | | | | | | | | | | | | | | | | | | | | | | | | | | | | | | | | | | | | | | | | | | | | | |
| <input type="checkbox"/> - | <input type="checkbox"/> - | | | | | | | | | | | | | | | | | | | | | | | | | | | | | | | | | | | | | | | | | | | | | | | | | | | | | | | | | | | | | | | | | | | | | | | | | | | | | | | | | | | | | | | | | | | | | | | | | | | | | | | | | | | | | | | | | | | | | | |
| LEFT SIDE LIGHTS | RIGHT SIDE LIGHTS | | | | | | | | | | | | | | | | | | | | | | | | | | | | | | | | | | | | | | | | | | | | | | | | | | | | | | | | | | | | | | | | | | | | | | | | | | | | | | | | | | | | | | | | | | | | | | | | | | | | | | | | | | | | | | | | | | | | | | |
| <input type="checkbox"/> 1 | <input type="checkbox"/> 8 | | | | | | | | | | | | | | | | | | | | | | | | | | | | | | | | | | | | | | | | | | | | | | | | | | | | | | | | | | | | | | | | | | | | | | | | | | | | | | | | | | | | | | | | | | | | | | | | | | | | | | | | | | | | | | | | | | | | | | |
| <input type="checkbox"/> - | <input type="checkbox"/> - | | | | | | | | | | | | | | | | | | | | | | | | | | | | | | | | | | | | | | | | | | | | | | | | | | | | | | | | | | | | | | | | | | | | | | | | | | | | | | | | | | | | | | | | | | | | | | | | | | | | | | | | | | | | | | | | | | | | | | |
| <input type="checkbox"/> 2 | <input type="checkbox"/> 4 | | | | | | | | | | | | | | | | | | | | | | | | | | | | | | | | | | | | | | | | | | | | | | | | | | | | | | | | | | | | | | | | | | | | | | | | | | | | | | | | | | | | | | | | | | | | | | | | | | | | | | | | | | | | | | | | | | | | | | |
| <input type="checkbox"/> - | <input type="checkbox"/> - | | | | | | | | | | | | | | | | | | | | | | | | | | | | | | | | | | | | | | | | | | | | | | | | | | | | | | | | | | | | | | | | | | | | | | | | | | | | | | | | | | | | | | | | | | | | | | | | | | | | | | | | | | | | | | | | | | | | | | |
| <input type="checkbox"/> 10 | <input type="checkbox"/> 5 | | | | | | | | | | | | | | | | | | | | | | | | | | | | | | | | | | | | | | | | | | | | | | | | | | | | | | | | | | | | | | | | | | | | | | | | | | | | | | | | | | | | | | | | | | | | | | | | | | | | | | | | | | | | | | | | | | | | | | |
| <input type="checkbox"/> - | <input type="checkbox"/> - | | | | | | | | | | | | | | | | | | | | | | | | | | | | | | | | | | | | | | | | | | | | | | | | | | | | | | | | | | | | | | | | | | | | | | | | | | | | | | | | | | | | | | | | | | | | | | | | | | | | | | | | | | | | | | | | | | | | | | |
| <input type="checkbox"/> 11 | <input type="checkbox"/> 12 | | | | | | | | | | | | | | | | | | | | | | | | | | | | | | | | | | | | | | | | | | | | | | | | | | | | | | | | | | | | | | | | | | | | | | | | | | | | | | | | | | | | | | | | | | | | | | | | | | | | | | | | | | | | | | | | | | | | | | |
| <input type="checkbox"/> - | <input type="checkbox"/> - | | | | | | | | | | | | | | | | | | | | | | | | | | | | | | | | | | | | | | | | | | | | | | | | | | | | | | | | | | | | | | | | | | | | | | | | | | | | | | | | | | | | | | | | | | | | | | | | | | | | | | | | | | | | | | | | | | | | | | |
| <input type="checkbox"/> 3 | <input type="checkbox"/> 6 | | | | | | | | | | | | | | | | | | | | | | | | | | | | | | | | | | | | | | | | | | | | | | | | | | | | | | | | | | | | | | | | | | | | | | | | | | | | | | | | | | | | | | | | | | | | | | | | | | | | | | | | | | | | | | | | | | | | | | |
| <input type="checkbox"/> - | <input type="checkbox"/> - | | | | | | | | | | | | | | | | | | | | | | | | | | | | | | | | | | | | | | | | | | | | | | | | | | | | | | | | | | | | | | | | | | | | | | | | | | | | | | | | | | | | | | | | | | | | | | | | | | | | | | | | | | | | | | | | | | | | | | |
| <input type="checkbox"/> 7 | <input type="checkbox"/> 9 | | | | | | | | | | | | | | | | | | | | | | | | | | | | | | | | | | | | | | | | | | | | | | | | | | | | | | | | | | | | | | | | | | | | | | | | | | | | | | | | | | | | | | | | | | | | | | | | | | | | | | | | | | | | | | | | | | | | | | |
| <input type="checkbox"/> - | <input type="checkbox"/> - | | | | | | | | | | | | | | | | | | | | | | | | | | | | | | | | | | | | | | | | | | | | | | | | | | | | | | | | | | | | | | | | | | | | | | | | | | | | | | | | | | | | | | | | | | | | | | | | | | | | | | | | | | | | | | | | | | | | | | |
| <input type="checkbox"/> - | <input type="checkbox"/> - | | | | | | | | | | | | | | | | | | | | | | | | | | | | | | | | | | | | | | | | | | | | | | | | | | | | | | | | | | | | | | | | | | | | | | | | | | | | | | | | | | | | | | | | | | | | | | | | | | | | | | | | | | | | | | | | | | | | | | |
| LEFT SIDE LIGHTS | RIGHT SIDE LIGHTS | | | | | | | | | | | | | | | | | | | | | | | | | | | | | | | | | | | | | | | | | | | | | | | | | | | | | | | | | | | | | | | | | | | | | | | | | | | | | | | | | | | | | | | | | | | | | | | | | | | | | | | | | | | | | | | | | | | | | | |
| <input type="checkbox"/> 11 | <input type="checkbox"/> 12 | | | | | | | | | | | | | | | | | | | | | | | | | | | | | | | | | | | | | | | | | | | | | | | | | | | | | | | | | | | | | | | | | | | | | | | | | | | | | | | | | | | | | | | | | | | | | | | | | | | | | | | | | | | | | | | | | | | | | | |
| <input type="checkbox"/> - | <input type="checkbox"/> - | | | | | | | | | | | | | | | | | | | | | | | | | | | | | | | | | | | | | | | | | | | | | | | | | | | | | | | | | | | | | | | | | | | | | | | | | | | | | | | | | | | | | | | | | | | | | | | | | | | | | | | | | | | | | | | | | | | | | | |
| <input type="checkbox"/> 1 | <input type="checkbox"/> 9 | | | | | | | | | | | | | | | | | | | | | | | | | | | | | | | | | | | | | | | | | | | | | | | | | | | | | | | | | | | | | | | | | | | | | | | | | | | | | | | | | | | | | | | | | | | | | | | | | | | | | | | | | | | | | | | | | | | | | | |
| <input type="checkbox"/> - | <input type="checkbox"/> - | | | | | | | | | | | | | | | | | | | | | | | | | | | | | | | | | | | | | | | | | | | | | | | | | | | | | | | | | | | | | | | | | | | | | | | | | | | | | | | | | | | | | | | | | | | | | | | | | | | | | | | | | | | | | | | | | | | | | | |
| <input type="checkbox"/> 6 | <input type="checkbox"/> 3 | | | | | | | | | | | | | | | | | | | | | | | | | | | | | | | | | | | | | | | | | | | | | | | | | | | | | | | | | | | | | | | | | | | | | | | | | | | | | | | | | | | | | | | | | | | | | | | | | | | | | | | | | | | | | | | | | | | | | | |
| <input type="checkbox"/> - | <input type="checkbox"/> - | | | | | | | | | | | | | | | | | | | | | | | | | | | | | | | | | | | | | | | | | | | | | | | | | | | | | | | | | | | | | | | | | | | | | | | | | | | | | | | | | | | | | | | | | | | | | | | | | | | | | | | | | | | | | | | | | | | | | | |
| <input type="checkbox"/> 4 | <input type="checkbox"/> 7 | | | | | | | | | | | | | | | | | | | | | | | | | | | | | | | | | | | | | | | | | | | | | | | | | | | | | | | | | | | | | | | | | | | | | | | | | | | | | | | | | | | | | | | | | | | | | | | | | | | | | | | | | | | | | | | | | | | | | | |
| <input type="checkbox"/> - | <input type="checkbox"/> - | | | | | | | | | | | | | | | | | | | | | | | | | | | | | | | | | | | | | | | | | | | | | | | | | | | | | | | | | | | | | | | | | | | | | | | | | | | | | | | | | | | | | | | | | | | | | | | | | | | | | | | | | | | | | | | | | | | | | | |
| <input type="checkbox"/> 2 | <input type="checkbox"/> 10 | | | | | | | | | | | | | | | | | | | | | | | | | | | | | | | | | | | | | | | | | | | | | | | | | | | | | | | | | | | | | | | | | | | | | | | | | | | | | | | | | | | | | | | | | | | | | | | | | | | | | | | | | | | | | | | | | | | | | | |
| <input type="checkbox"/> - | <input type="checkbox"/> - | | | | | | | | | | | | | | | | | | | | | | | | | | | | | | | | | | | | | | | | | | | | | | | | | | | | | | | | | | | | | | | | | | | | | | | | | | | | | | | | | | | | | | | | | | | | | | | | | | | | | | | | | | | | | | | | | | | | | | |
| <input type="checkbox"/> 8 | <input type="checkbox"/> 5 | | | | | | | | | | | | | | | | | | | | | | | | | | | | | | | | | | | | | | | | | | | | | | | | | | | | | | | | | | | | | | | | | | | | | | | | | | | | | | | | | | | | | | | | | | | | | | | | | | | | | | | | | | | | | | | | | | | | | | |
| <input type="checkbox"/> - | <input type="checkbox"/> - | | | | | | | | | | | | | | | | | | | | | | | | | | | | | | | | | | | | | | | | | | | | | | | | | | | | | | | | | | | | | | | | | | | | | | | | | | | | | | | | | | | | | | | | | | | | | | | | | | | | | | | | | | | | | | | | | | | | | | |
| <input type="checkbox"/> - | <input type="checkbox"/> - | | | | | | | | | | | | | | | | | | | | | | | | | | | | | | | | | | | | | | | | | | | | | | | | | | | | | | | | | | | | | | | | | | | | | | | | | | | | | | | | | | | | | | | | | | | | | | | | | | | | | | | | | | | | | | | | | | | | | | |
| <p>Matching answers, 14 questions, 42 points</p> <p style="text-align: center;">Code: 5086</p> <table style="width: 100%; border-collapse: collapse;"> <thead> <tr> <th style="text-align: left;">LEFT SIDE LIGHTS</th> <th style="text-align: left;">RIGHT SIDE LIGHTS</th> </tr> </thead> <tbody> <tr><td><input type="checkbox"/> 13</td><td><input type="checkbox"/> 1</td></tr> <tr><td><input type="checkbox"/> -</td><td><input type="checkbox"/> -</td></tr> <tr><td><input type="checkbox"/> 5</td><td><input type="checkbox"/> 2</td></tr> <tr><td><input type="checkbox"/> -</td><td><input type="checkbox"/> -</td></tr> <tr><td><input type="checkbox"/> 11</td><td><input type="checkbox"/> 4</td></tr> <tr><td><input type="checkbox"/> -</td><td><input type="checkbox"/> -</td></tr> <tr><td><input type="checkbox"/> 9</td><td><input type="checkbox"/> 3</td></tr> <tr><td><input type="checkbox"/> -</td><td><input type="checkbox"/> -</td></tr> <tr><td><input type="checkbox"/> 14</td><td><input type="checkbox"/> 8</td></tr> <tr><td><input type="checkbox"/> -</td><td><input type="checkbox"/> -</td></tr> <tr><td><input type="checkbox"/> 6</td><td><input type="checkbox"/> 10</td></tr> <tr><td><input type="checkbox"/> -</td><td><input type="checkbox"/> -</td></tr> <tr><td><input type="checkbox"/> 7</td><td><input type="checkbox"/> 12</td></tr> </tbody> </table> | LEFT SIDE LIGHTS | RIGHT SIDE LIGHTS | <input type="checkbox"/> 13 | <input type="checkbox"/> 1 | <input type="checkbox"/> - | <input type="checkbox"/> - | <input type="checkbox"/> 5 | <input type="checkbox"/> 2 | <input type="checkbox"/> - | <input type="checkbox"/> - | <input type="checkbox"/> 11 | <input type="checkbox"/> 4 | <input type="checkbox"/> - | <input type="checkbox"/> - | <input type="checkbox"/> 9 | <input type="checkbox"/> 3 | <input type="checkbox"/> - | <input type="checkbox"/> - | <input type="checkbox"/> 14 | <input type="checkbox"/> 8 | <input type="checkbox"/> - | <input type="checkbox"/> - | <input type="checkbox"/> 6 | <input type="checkbox"/> 10 | <input type="checkbox"/> - | <input type="checkbox"/> - | <input type="checkbox"/> 7 | <input type="checkbox"/> 12 | <p>Matching answers, 14 questions, 42 points</p> <p style="text-align: center;">Code: 5126</p> <table style="width: 100%; border-collapse: collapse;"> <thead> <tr> <th style="text-align: left;">LEFT SIDE LIGHTS</th> <th style="text-align: left;">RIGHT SIDE LIGHTS</th> </tr> </thead> <tbody> <tr><td><input type="checkbox"/> 6</td><td><input type="checkbox"/> 10</td></tr> <tr><td><input type="checkbox"/> -</td><td><input type="checkbox"/> -</td></tr> <tr><td><input type="checkbox"/> 12</td><td><input type="checkbox"/> 3</td></tr> <tr><td><input type="checkbox"/> -</td><td><input type="checkbox"/> -</td></tr> <tr><td><input type="checkbox"/> 7</td><td><input type="checkbox"/> 8</td></tr> <tr><td><input type="checkbox"/> -</td><td><input type="checkbox"/> -</td></tr> <tr><td><input type="checkbox"/> 5</td><td><input type="checkbox"/> 9</td></tr> <tr><td><input type="checkbox"/> -</td><td><input type="checkbox"/> -</td></tr> <tr><td><input type="checkbox"/> 11</td><td><input type="checkbox"/> 13</td></tr> <tr><td><input type="checkbox"/> -</td><td><input type="checkbox"/> -</td></tr> <tr><td><input type="checkbox"/> 14</td><td><input type="checkbox"/> 4</td></tr> <tr><td><input type="checkbox"/> -</td><td><input type="checkbox"/> -</td></tr> <tr><td><input type="checkbox"/> 1</td><td><input type="checkbox"/> 2</td></tr> </tbody> </table> | LEFT SIDE LIGHTS | RIGHT SIDE LIGHTS | <input type="checkbox"/> 6 | <input type="checkbox"/> 10 | <input type="checkbox"/> - | <input type="checkbox"/> - | <input type="checkbox"/> 12 | <input type="checkbox"/> 3 | <input type="checkbox"/> - | <input type="checkbox"/> - | <input type="checkbox"/> 7 | <input type="checkbox"/> 8 | <input type="checkbox"/> - | <input type="checkbox"/> - | <input type="checkbox"/> 5 | <input type="checkbox"/> 9 | <input type="checkbox"/> - | <input type="checkbox"/> - | <input type="checkbox"/> 11 | <input type="checkbox"/> 13 | <input type="checkbox"/> - | <input type="checkbox"/> - | <input type="checkbox"/> 14 | <input type="checkbox"/> 4 | <input type="checkbox"/> - | <input type="checkbox"/> - | <input type="checkbox"/> 1 | <input type="checkbox"/> 2 | <p>Matching answers, 16 questions, 48 points</p> <p style="text-align: center;">Code: 6982</p> <table style="width: 100%; border-collapse: collapse;"> <thead> <tr> <th style="text-align: left;">LEFT SIDE LIGHTS</th> <th style="text-align: left;">RIGHT SIDE LIGHTS</th> </tr> </thead> <tbody> <tr><td><input type="checkbox"/> 8</td><td><input type="checkbox"/> 11</td></tr> <tr><td><input type="checkbox"/> 2</td><td><input type="checkbox"/> 1</td></tr> <tr><td><input type="checkbox"/> 3</td><td><input type="checkbox"/> 15</td></tr> <tr><td><input type="checkbox"/> 7</td><td><input type="checkbox"/> 14</td></tr> <tr><td><input type="checkbox"/> 5</td><td><input type="checkbox"/> 4</td></tr> <tr><td><input type="checkbox"/> 10</td><td><input type="checkbox"/> 12</td></tr> <tr><td><input type="checkbox"/> 16</td><td><input type="checkbox"/> 6</td></tr> <tr><td><input type="checkbox"/> 9</td><td><input type="checkbox"/> 13</td></tr> <tr><td><input type="checkbox"/> -</td><td><input type="checkbox"/> -</td></tr> <tr><td><input type="checkbox"/> -</td><td><input type="checkbox"/> -</td></tr> <tr><td><input type="checkbox"/> -</td><td><input type="checkbox"/> -</td></tr> <tr><td><input type="checkbox"/> -</td><td><input type="checkbox"/> -</td></tr> <tr><td><input type="checkbox"/> -</td><td><input type="checkbox"/> -</td></tr> <tr><td><input type="checkbox"/> -</td><td><input type="checkbox"/> -</td></tr> </tbody> </table> | LEFT SIDE LIGHTS | RIGHT SIDE LIGHTS | <input type="checkbox"/> 8 | <input type="checkbox"/> 11 | <input type="checkbox"/> 2 | <input type="checkbox"/> 1 | <input type="checkbox"/> 3 | <input type="checkbox"/> 15 | <input type="checkbox"/> 7 | <input type="checkbox"/> 14 | <input type="checkbox"/> 5 | <input type="checkbox"/> 4 | <input type="checkbox"/> 10 | <input type="checkbox"/> 12 | <input type="checkbox"/> 16 | <input type="checkbox"/> 6 | <input type="checkbox"/> 9 | <input type="checkbox"/> 13 | <input type="checkbox"/> - | <input type="checkbox"/> - | <input type="checkbox"/> - | <input type="checkbox"/> - | <input type="checkbox"/> - | <input type="checkbox"/> - | <input type="checkbox"/> - | <input type="checkbox"/> - | <input type="checkbox"/> - | <input type="checkbox"/> - | <input type="checkbox"/> - | <input type="checkbox"/> - | <p>Matching answers, 16 questions, 48 points</p> <p style="text-align: center;">Code: 6892</p> <table style="width: 100%; border-collapse: collapse;"> <thead> <tr> <th style="text-align: left;">LEFT SIDE LIGHTS</th> <th style="text-align: left;">RIGHT SIDE LIGHTS</th> </tr> </thead> <tbody> <tr><td><input type="checkbox"/> 8</td><td><input type="checkbox"/> 7</td></tr> <tr><td><input type="checkbox"/> 16</td><td><input type="checkbox"/> 11</td></tr> <tr><td><input type="checkbox"/> 6</td><td><input type="checkbox"/> 13</td></tr> <tr><td><input type="checkbox"/> 4</td><td><input type="checkbox"/> 15</td></tr> <tr><td><input type="checkbox"/> 2</td><td><input type="checkbox"/> 12</td></tr> <tr><td><input type="checkbox"/> 5</td><td><input type="checkbox"/> 1</td></tr> <tr><td><input type="checkbox"/> 3</td><td><input type="checkbox"/> 14</td></tr> <tr><td><input type="checkbox"/> 9</td><td><input type="checkbox"/> 10</td></tr> <tr><td><input type="checkbox"/> -</td><td><input type="checkbox"/> -</td></tr> <tr><td><input type="checkbox"/> -</td><td><input type="checkbox"/> -</td></tr> <tr><td><input type="checkbox"/> -</td><td><input type="checkbox"/> -</td></tr> <tr><td><input type="checkbox"/> -</td><td><input type="checkbox"/> -</td></tr> <tr><td><input type="checkbox"/> -</td><td><input type="checkbox"/> -</td></tr> <tr><td><input type="checkbox"/> -</td><td><input type="checkbox"/> -</td></tr> </tbody> </table> | LEFT SIDE LIGHTS | RIGHT SIDE LIGHTS | <input type="checkbox"/> 8 | <input type="checkbox"/> 7 | <input type="checkbox"/> 16 | <input type="checkbox"/> 11 | <input type="checkbox"/> 6 | <input type="checkbox"/> 13 | <input type="checkbox"/> 4 | <input type="checkbox"/> 15 | <input type="checkbox"/> 2 | <input type="checkbox"/> 12 | <input type="checkbox"/> 5 | <input type="checkbox"/> 1 | <input type="checkbox"/> 3 | <input type="checkbox"/> 14 | <input type="checkbox"/> 9 | <input type="checkbox"/> 10 | <input type="checkbox"/> - | <input type="checkbox"/> - | <input type="checkbox"/> - | <input type="checkbox"/> - | <input type="checkbox"/> - | <input type="checkbox"/> - | <input type="checkbox"/> - | <input type="checkbox"/> - | <input type="checkbox"/> - | <input type="checkbox"/> - | <input type="checkbox"/> - | <input type="checkbox"/> - |
| LEFT SIDE LIGHTS | RIGHT SIDE LIGHTS | | | | | | | | | | | | | | | | | | | | | | | | | | | | | | | | | | | | | | | | | | | | | | | | | | | | | | | | | | | | | | | | | | | | | | | | | | | | | | | | | | | | | | | | | | | | | | | | | | | | | | | | | | | | | | | | | | | | | | |
| <input type="checkbox"/> 13 | <input type="checkbox"/> 1 | | | | | | | | | | | | | | | | | | | | | | | | | | | | | | | | | | | | | | | | | | | | | | | | | | | | | | | | | | | | | | | | | | | | | | | | | | | | | | | | | | | | | | | | | | | | | | | | | | | | | | | | | | | | | | | | | | | | | | |
| <input type="checkbox"/> - | <input type="checkbox"/> - | | | | | | | | | | | | | | | | | | | | | | | | | | | | | | | | | | | | | | | | | | | | | | | | | | | | | | | | | | | | | | | | | | | | | | | | | | | | | | | | | | | | | | | | | | | | | | | | | | | | | | | | | | | | | | | | | | | | | | |
| <input type="checkbox"/> 5 | <input type="checkbox"/> 2 | | | | | | | | | | | | | | | | | | | | | | | | | | | | | | | | | | | | | | | | | | | | | | | | | | | | | | | | | | | | | | | | | | | | | | | | | | | | | | | | | | | | | | | | | | | | | | | | | | | | | | | | | | | | | | | | | | | | | | |
| <input type="checkbox"/> - | <input type="checkbox"/> - | | | | | | | | | | | | | | | | | | | | | | | | | | | | | | | | | | | | | | | | | | | | | | | | | | | | | | | | | | | | | | | | | | | | | | | | | | | | | | | | | | | | | | | | | | | | | | | | | | | | | | | | | | | | | | | | | | | | | | |
| <input type="checkbox"/> 11 | <input type="checkbox"/> 4 | | | | | | | | | | | | | | | | | | | | | | | | | | | | | | | | | | | | | | | | | | | | | | | | | | | | | | | | | | | | | | | | | | | | | | | | | | | | | | | | | | | | | | | | | | | | | | | | | | | | | | | | | | | | | | | | | | | | | | |
| <input type="checkbox"/> - | <input type="checkbox"/> - | | | | | | | | | | | | | | | | | | | | | | | | | | | | | | | | | | | | | | | | | | | | | | | | | | | | | | | | | | | | | | | | | | | | | | | | | | | | | | | | | | | | | | | | | | | | | | | | | | | | | | | | | | | | | | | | | | | | | | |
| <input type="checkbox"/> 9 | <input type="checkbox"/> 3 | | | | | | | | | | | | | | | | | | | | | | | | | | | | | | | | | | | | | | | | | | | | | | | | | | | | | | | | | | | | | | | | | | | | | | | | | | | | | | | | | | | | | | | | | | | | | | | | | | | | | | | | | | | | | | | | | | | | | | |
| <input type="checkbox"/> - | <input type="checkbox"/> - | | | | | | | | | | | | | | | | | | | | | | | | | | | | | | | | | | | | | | | | | | | | | | | | | | | | | | | | | | | | | | | | | | | | | | | | | | | | | | | | | | | | | | | | | | | | | | | | | | | | | | | | | | | | | | | | | | | | | | |
| <input type="checkbox"/> 14 | <input type="checkbox"/> 8 | | | | | | | | | | | | | | | | | | | | | | | | | | | | | | | | | | | | | | | | | | | | | | | | | | | | | | | | | | | | | | | | | | | | | | | | | | | | | | | | | | | | | | | | | | | | | | | | | | | | | | | | | | | | | | | | | | | | | | |
| <input type="checkbox"/> - | <input type="checkbox"/> - | | | | | | | | | | | | | | | | | | | | | | | | | | | | | | | | | | | | | | | | | | | | | | | | | | | | | | | | | | | | | | | | | | | | | | | | | | | | | | | | | | | | | | | | | | | | | | | | | | | | | | | | | | | | | | | | | | | | | | |
| <input type="checkbox"/> 6 | <input type="checkbox"/> 10 | | | | | | | | | | | | | | | | | | | | | | | | | | | | | | | | | | | | | | | | | | | | | | | | | | | | | | | | | | | | | | | | | | | | | | | | | | | | | | | | | | | | | | | | | | | | | | | | | | | | | | | | | | | | | | | | | | | | | | |
| <input type="checkbox"/> - | <input type="checkbox"/> - | | | | | | | | | | | | | | | | | | | | | | | | | | | | | | | | | | | | | | | | | | | | | | | | | | | | | | | | | | | | | | | | | | | | | | | | | | | | | | | | | | | | | | | | | | | | | | | | | | | | | | | | | | | | | | | | | | | | | | |
| <input type="checkbox"/> 7 | <input type="checkbox"/> 12 | | | | | | | | | | | | | | | | | | | | | | | | | | | | | | | | | | | | | | | | | | | | | | | | | | | | | | | | | | | | | | | | | | | | | | | | | | | | | | | | | | | | | | | | | | | | | | | | | | | | | | | | | | | | | | | | | | | | | | |
| LEFT SIDE LIGHTS | RIGHT SIDE LIGHTS | | | | | | | | | | | | | | | | | | | | | | | | | | | | | | | | | | | | | | | | | | | | | | | | | | | | | | | | | | | | | | | | | | | | | | | | | | | | | | | | | | | | | | | | | | | | | | | | | | | | | | | | | | | | | | | | | | | | | | |
| <input type="checkbox"/> 6 | <input type="checkbox"/> 10 | | | | | | | | | | | | | | | | | | | | | | | | | | | | | | | | | | | | | | | | | | | | | | | | | | | | | | | | | | | | | | | | | | | | | | | | | | | | | | | | | | | | | | | | | | | | | | | | | | | | | | | | | | | | | | | | | | | | | | |
| <input type="checkbox"/> - | <input type="checkbox"/> - | | | | | | | | | | | | | | | | | | | | | | | | | | | | | | | | | | | | | | | | | | | | | | | | | | | | | | | | | | | | | | | | | | | | | | | | | | | | | | | | | | | | | | | | | | | | | | | | | | | | | | | | | | | | | | | | | | | | | | |
| <input type="checkbox"/> 12 | <input type="checkbox"/> 3 | | | | | | | | | | | | | | | | | | | | | | | | | | | | | | | | | | | | | | | | | | | | | | | | | | | | | | | | | | | | | | | | | | | | | | | | | | | | | | | | | | | | | | | | | | | | | | | | | | | | | | | | | | | | | | | | | | | | | | |
| <input type="checkbox"/> - | <input type="checkbox"/> - | | | | | | | | | | | | | | | | | | | | | | | | | | | | | | | | | | | | | | | | | | | | | | | | | | | | | | | | | | | | | | | | | | | | | | | | | | | | | | | | | | | | | | | | | | | | | | | | | | | | | | | | | | | | | | | | | | | | | | |
| <input type="checkbox"/> 7 | <input type="checkbox"/> 8 | | | | | | | | | | | | | | | | | | | | | | | | | | | | | | | | | | | | | | | | | | | | | | | | | | | | | | | | | | | | | | | | | | | | | | | | | | | | | | | | | | | | | | | | | | | | | | | | | | | | | | | | | | | | | | | | | | | | | | |
| <input type="checkbox"/> - | <input type="checkbox"/> - | | | | | | | | | | | | | | | | | | | | | | | | | | | | | | | | | | | | | | | | | | | | | | | | | | | | | | | | | | | | | | | | | | | | | | | | | | | | | | | | | | | | | | | | | | | | | | | | | | | | | | | | | | | | | | | | | | | | | | |
| <input type="checkbox"/> 5 | <input type="checkbox"/> 9 | | | | | | | | | | | | | | | | | | | | | | | | | | | | | | | | | | | | | | | | | | | | | | | | | | | | | | | | | | | | | | | | | | | | | | | | | | | | | | | | | | | | | | | | | | | | | | | | | | | | | | | | | | | | | | | | | | | | | | |
| <input type="checkbox"/> - | <input type="checkbox"/> - | | | | | | | | | | | | | | | | | | | | | | | | | | | | | | | | | | | | | | | | | | | | | | | | | | | | | | | | | | | | | | | | | | | | | | | | | | | | | | | | | | | | | | | | | | | | | | | | | | | | | | | | | | | | | | | | | | | | | | |
| <input type="checkbox"/> 11 | <input type="checkbox"/> 13 | | | | | | | | | | | | | | | | | | | | | | | | | | | | | | | | | | | | | | | | | | | | | | | | | | | | | | | | | | | | | | | | | | | | | | | | | | | | | | | | | | | | | | | | | | | | | | | | | | | | | | | | | | | | | | | | | | | | | | |
| <input type="checkbox"/> - | <input type="checkbox"/> - | | | | | | | | | | | | | | | | | | | | | | | | | | | | | | | | | | | | | | | | | | | | | | | | | | | | | | | | | | | | | | | | | | | | | | | | | | | | | | | | | | | | | | | | | | | | | | | | | | | | | | | | | | | | | | | | | | | | | | |
| <input type="checkbox"/> 14 | <input type="checkbox"/> 4 | | | | | | | | | | | | | | | | | | | | | | | | | | | | | | | | | | | | | | | | | | | | | | | | | | | | | | | | | | | | | | | | | | | | | | | | | | | | | | | | | | | | | | | | | | | | | | | | | | | | | | | | | | | | | | | | | | | | | | |
| <input type="checkbox"/> - | <input type="checkbox"/> - | | | | | | | | | | | | | | | | | | | | | | | | | | | | | | | | | | | | | | | | | | | | | | | | | | | | | | | | | | | | | | | | | | | | | | | | | | | | | | | | | | | | | | | | | | | | | | | | | | | | | | | | | | | | | | | | | | | | | | |
| <input type="checkbox"/> 1 | <input type="checkbox"/> 2 | | | | | | | | | | | | | | | | | | | | | | | | | | | | | | | | | | | | | | | | | | | | | | | | | | | | | | | | | | | | | | | | | | | | | | | | | | | | | | | | | | | | | | | | | | | | | | | | | | | | | | | | | | | | | | | | | | | | | | |
| LEFT SIDE LIGHTS | RIGHT SIDE LIGHTS | | | | | | | | | | | | | | | | | | | | | | | | | | | | | | | | | | | | | | | | | | | | | | | | | | | | | | | | | | | | | | | | | | | | | | | | | | | | | | | | | | | | | | | | | | | | | | | | | | | | | | | | | | | | | | | | | | | | | | |
| <input type="checkbox"/> 8 | <input type="checkbox"/> 11 | | | | | | | | | | | | | | | | | | | | | | | | | | | | | | | | | | | | | | | | | | | | | | | | | | | | | | | | | | | | | | | | | | | | | | | | | | | | | | | | | | | | | | | | | | | | | | | | | | | | | | | | | | | | | | | | | | | | | | |
| <input type="checkbox"/> 2 | <input type="checkbox"/> 1 | | | | | | | | | | | | | | | | | | | | | | | | | | | | | | | | | | | | | | | | | | | | | | | | | | | | | | | | | | | | | | | | | | | | | | | | | | | | | | | | | | | | | | | | | | | | | | | | | | | | | | | | | | | | | | | | | | | | | | |
| <input type="checkbox"/> 3 | <input type="checkbox"/> 15 | | | | | | | | | | | | | | | | | | | | | | | | | | | | | | | | | | | | | | | | | | | | | | | | | | | | | | | | | | | | | | | | | | | | | | | | | | | | | | | | | | | | | | | | | | | | | | | | | | | | | | | | | | | | | | | | | | | | | | |
| <input type="checkbox"/> 7 | <input type="checkbox"/> 14 | | | | | | | | | | | | | | | | | | | | | | | | | | | | | | | | | | | | | | | | | | | | | | | | | | | | | | | | | | | | | | | | | | | | | | | | | | | | | | | | | | | | | | | | | | | | | | | | | | | | | | | | | | | | | | | | | | | | | | |
| <input type="checkbox"/> 5 | <input type="checkbox"/> 4 | | | | | | | | | | | | | | | | | | | | | | | | | | | | | | | | | | | | | | | | | | | | | | | | | | | | | | | | | | | | | | | | | | | | | | | | | | | | | | | | | | | | | | | | | | | | | | | | | | | | | | | | | | | | | | | | | | | | | | |
| <input type="checkbox"/> 10 | <input type="checkbox"/> 12 | | | | | | | | | | | | | | | | | | | | | | | | | | | | | | | | | | | | | | | | | | | | | | | | | | | | | | | | | | | | | | | | | | | | | | | | | | | | | | | | | | | | | | | | | | | | | | | | | | | | | | | | | | | | | | | | | | | | | | |
| <input type="checkbox"/> 16 | <input type="checkbox"/> 6 | | | | | | | | | | | | | | | | | | | | | | | | | | | | | | | | | | | | | | | | | | | | | | | | | | | | | | | | | | | | | | | | | | | | | | | | | | | | | | | | | | | | | | | | | | | | | | | | | | | | | | | | | | | | | | | | | | | | | | |
| <input type="checkbox"/> 9 | <input type="checkbox"/> 13 | | | | | | | | | | | | | | | | | | | | | | | | | | | | | | | | | | | | | | | | | | | | | | | | | | | | | | | | | | | | | | | | | | | | | | | | | | | | | | | | | | | | | | | | | | | | | | | | | | | | | | | | | | | | | | | | | | | | | | |
| <input type="checkbox"/> - | <input type="checkbox"/> - | | | | | | | | | | | | | | | | | | | | | | | | | | | | | | | | | | | | | | | | | | | | | | | | | | | | | | | | | | | | | | | | | | | | | | | | | | | | | | | | | | | | | | | | | | | | | | | | | | | | | | | | | | | | | | | | | | | | | | |
| <input type="checkbox"/> - | <input type="checkbox"/> - | | | | | | | | | | | | | | | | | | | | | | | | | | | | | | | | | | | | | | | | | | | | | | | | | | | | | | | | | | | | | | | | | | | | | | | | | | | | | | | | | | | | | | | | | | | | | | | | | | | | | | | | | | | | | | | | | | | | | | |
| <input type="checkbox"/> - | <input type="checkbox"/> - | | | | | | | | | | | | | | | | | | | | | | | | | | | | | | | | | | | | | | | | | | | | | | | | | | | | | | | | | | | | | | | | | | | | | | | | | | | | | | | | | | | | | | | | | | | | | | | | | | | | | | | | | | | | | | | | | | | | | | |
| <input type="checkbox"/> - | <input type="checkbox"/> - | | | | | | | | | | | | | | | | | | | | | | | | | | | | | | | | | | | | | | | | | | | | | | | | | | | | | | | | | | | | | | | | | | | | | | | | | | | | | | | | | | | | | | | | | | | | | | | | | | | | | | | | | | | | | | | | | | | | | | |
| <input type="checkbox"/> - | <input type="checkbox"/> - | | | | | | | | | | | | | | | | | | | | | | | | | | | | | | | | | | | | | | | | | | | | | | | | | | | | | | | | | | | | | | | | | | | | | | | | | | | | | | | | | | | | | | | | | | | | | | | | | | | | | | | | | | | | | | | | | | | | | | |
| <input type="checkbox"/> - | <input type="checkbox"/> - | | | | | | | | | | | | | | | | | | | | | | | | | | | | | | | | | | | | | | | | | | | | | | | | | | | | | | | | | | | | | | | | | | | | | | | | | | | | | | | | | | | | | | | | | | | | | | | | | | | | | | | | | | | | | | | | | | | | | | |
| LEFT SIDE LIGHTS | RIGHT SIDE LIGHTS | | | | | | | | | | | | | | | | | | | | | | | | | | | | | | | | | | | | | | | | | | | | | | | | | | | | | | | | | | | | | | | | | | | | | | | | | | | | | | | | | | | | | | | | | | | | | | | | | | | | | | | | | | | | | | | | | | | | | | |
| <input type="checkbox"/> 8 | <input type="checkbox"/> 7 | | | | | | | | | | | | | | | | | | | | | | | | | | | | | | | | | | | | | | | | | | | | | | | | | | | | | | | | | | | | | | | | | | | | | | | | | | | | | | | | | | | | | | | | | | | | | | | | | | | | | | | | | | | | | | | | | | | | | | |
| <input type="checkbox"/> 16 | <input type="checkbox"/> 11 | | | | | | | | | | | | | | | | | | | | | | | | | | | | | | | | | | | | | | | | | | | | | | | | | | | | | | | | | | | | | | | | | | | | | | | | | | | | | | | | | | | | | | | | | | | | | | | | | | | | | | | | | | | | | | | | | | | | | | |
| <input type="checkbox"/> 6 | <input type="checkbox"/> 13 | | | | | | | | | | | | | | | | | | | | | | | | | | | | | | | | | | | | | | | | | | | | | | | | | | | | | | | | | | | | | | | | | | | | | | | | | | | | | | | | | | | | | | | | | | | | | | | | | | | | | | | | | | | | | | | | | | | | | | |
| <input type="checkbox"/> 4 | <input type="checkbox"/> 15 | | | | | | | | | | | | | | | | | | | | | | | | | | | | | | | | | | | | | | | | | | | | | | | | | | | | | | | | | | | | | | | | | | | | | | | | | | | | | | | | | | | | | | | | | | | | | | | | | | | | | | | | | | | | | | | | | | | | | | |
| <input type="checkbox"/> 2 | <input type="checkbox"/> 12 | | | | | | | | | | | | | | | | | | | | | | | | | | | | | | | | | | | | | | | | | | | | | | | | | | | | | | | | | | | | | | | | | | | | | | | | | | | | | | | | | | | | | | | | | | | | | | | | | | | | | | | | | | | | | | | | | | | | | | |
| <input type="checkbox"/> 5 | <input type="checkbox"/> 1 | | | | | | | | | | | | | | | | | | | | | | | | | | | | | | | | | | | | | | | | | | | | | | | | | | | | | | | | | | | | | | | | | | | | | | | | | | | | | | | | | | | | | | | | | | | | | | | | | | | | | | | | | | | | | | | | | | | | | | |
| <input type="checkbox"/> 3 | <input type="checkbox"/> 14 | | | | | | | | | | | | | | | | | | | | | | | | | | | | | | | | | | | | | | | | | | | | | | | | | | | | | | | | | | | | | | | | | | | | | | | | | | | | | | | | | | | | | | | | | | | | | | | | | | | | | | | | | | | | | | | | | | | | | | |
| <input type="checkbox"/> 9 | <input type="checkbox"/> 10 | | | | | | | | | | | | | | | | | | | | | | | | | | | | | | | | | | | | | | | | | | | | | | | | | | | | | | | | | | | | | | | | | | | | | | | | | | | | | | | | | | | | | | | | | | | | | | | | | | | | | | | | | | | | | | | | | | | | | | |
| <input type="checkbox"/> - | <input type="checkbox"/> - | | | | | | | | | | | | | | | | | | | | | | | | | | | | | | | | | | | | | | | | | | | | | | | | | | | | | | | | | | | | | | | | | | | | | | | | | | | | | | | | | | | | | | | | | | | | | | | | | | | | | | | | | | | | | | | | | | | | | | |
| <input type="checkbox"/> - | <input type="checkbox"/> - | | | | | | | | | | | | | | | | | | | | | | | | | | | | | | | | | | | | | | | | | | | | | | | | | | | | | | | | | | | | | | | | | | | | | | | | | | | | | | | | | | | | | | | | | | | | | | | | | | | | | | | | | | | | | | | | | | | | | | |
| <input type="checkbox"/> - | <input type="checkbox"/> - | | | | | | | | | | | | | | | | | | | | | | | | | | | | | | | | | | | | | | | | | | | | | | | | | | | | | | | | | | | | | | | | | | | | | | | | | | | | | | | | | | | | | | | | | | | | | | | | | | | | | | | | | | | | | | | | | | | | | | |
| <input type="checkbox"/> - | <input type="checkbox"/> - | | | | | | | | | | | | | | | | | | | | | | | | | | | | | | | | | | | | | | | | | | | | | | | | | | | | | | | | | | | | | | | | | | | | | | | | | | | | | | | | | | | | | | | | | | | | | | | | | | | | | | | | | | | | | | | | | | | | | | |
| <input type="checkbox"/> - | <input type="checkbox"/> - | | | | | | | | | | | | | | | | | | | | | | | | | | | | | | | | | | | | | | | | | | | | | | | | | | | | | | | | | | | | | | | | | | | | | | | | | | | | | | | | | | | | | | | | | | | | | | | | | | | | | | | | | | | | | | | | | | | | | | |
| <input type="checkbox"/> - | <input type="checkbox"/> - | | | | | | | | | | | | | | | | | | | | | | | | | | | | | | | | | | | | | | | | | | | | | | | | | | | | | | | | | | | | | | | | | | | | | | | | | | | | | | | | | | | | | | | | | | | | | | | | | | | | | | | | | | | | | | | | | | | | | | |
| <p>Matching answers, 20 questions, 60 points</p> <p style="text-align: center;">Code: 8452</p> <table style="width: 100%; border-collapse: collapse;"> <thead> <tr> <th style="text-align: left;">LEFT SIDE LIGHTS</th> <th style="text-align: left;">RIGHT SIDE LIGHTS</th> </tr> </thead> <tbody> <tr><td><input type="checkbox"/> 3</td><td><input type="checkbox"/> 18</td></tr> <tr><td><input type="checkbox"/> 14</td><td><input type="checkbox"/> 2</td></tr> <tr><td><input type="checkbox"/> 8</td><td><input type="checkbox"/> 10</td></tr> <tr><td><input type="checkbox"/> 12</td><td><input type="checkbox"/> 19</td></tr> <tr><td><input type="checkbox"/> 6</td><td><input type="checkbox"/> 1</td></tr> <tr><td><input type="checkbox"/> 5</td><td><input type="checkbox"/> 7</td></tr> <tr><td><input type="checkbox"/> 15</td><td><input type="checkbox"/> 11</td></tr> <tr><td><input type="checkbox"/> 20</td><td><input type="checkbox"/> 9</td></tr> <tr><td><input type="checkbox"/> 16</td><td><input type="checkbox"/> 13</td></tr> <tr><td><input type="checkbox"/> 17</td><td><input type="checkbox"/> 4</td></tr> <tr><td><input type="checkbox"/> -</td><td><input type="checkbox"/> -</td></tr> <tr><td><input type="checkbox"/> -</td><td><input type="checkbox"/> -</td></tr> <tr><td><input type="checkbox"/> -</td><td><input type="checkbox"/> -</td></tr> </tbody> </table> | LEFT SIDE LIGHTS | RIGHT SIDE LIGHTS | <input type="checkbox"/> 3 | <input type="checkbox"/> 18 | <input type="checkbox"/> 14 | <input type="checkbox"/> 2 | <input type="checkbox"/> 8 | <input type="checkbox"/> 10 | <input type="checkbox"/> 12 | <input type="checkbox"/> 19 | <input type="checkbox"/> 6 | <input type="checkbox"/> 1 | <input type="checkbox"/> 5 | <input type="checkbox"/> 7 | <input type="checkbox"/> 15 | <input type="checkbox"/> 11 | <input type="checkbox"/> 20 | <input type="checkbox"/> 9 | <input type="checkbox"/> 16 | <input type="checkbox"/> 13 | <input type="checkbox"/> 17 | <input type="checkbox"/> 4 | <input type="checkbox"/> - | <input type="checkbox"/> - | <input type="checkbox"/> - | <input type="checkbox"/> - | <input type="checkbox"/> - | <input type="checkbox"/> - | <p>Matching answers, 20 questions, 60 points</p> <p style="text-align: center;">Code: 8018</p> <table style="width: 100%; border-collapse: collapse;"> <thead> <tr> <th style="text-align: left;">LEFT SIDE LIGHTS</th> <th style="text-align: left;">RIGHT SIDE LIGHTS</th> </tr> </thead> <tbody> <tr><td><input type="checkbox"/> 3</td><td><input type="checkbox"/> 8</td></tr> <tr><td><input type="checkbox"/> 14</td><td><input type="checkbox"/> 12</td></tr> <tr><td><input type="checkbox"/> 17</td><td><input type="checkbox"/> 2</td></tr> <tr><td><input type="checkbox"/> 4</td><td><input type="checkbox"/> 5</td></tr> <tr><td><input type="checkbox"/> 1</td><td><input type="checkbox"/> 13</td></tr> <tr><td><input type="checkbox"/> 20</td><td><input type="checkbox"/> 7</td></tr> <tr><td><input type="checkbox"/> 11</td><td><input type="checkbox"/> 19</td></tr> <tr><td><input type="checkbox"/> 18</td><td><input type="checkbox"/> 6</td></tr> <tr><td><input type="checkbox"/> 15</td><td><input type="checkbox"/> 9</td></tr> <tr><td><input type="checkbox"/> 16</td><td><input type="checkbox"/> 10</td></tr> <tr><td><input type="checkbox"/> -</td><td><input type="checkbox"/> -</td></tr> <tr><td><input type="checkbox"/> -</td><td><input type="checkbox"/> -</td></tr> <tr><td><input type="checkbox"/> -</td><td><input type="checkbox"/> -</td></tr> </tbody> </table> | LEFT SIDE LIGHTS | RIGHT SIDE LIGHTS | <input type="checkbox"/> 3 | <input type="checkbox"/> 8 | <input type="checkbox"/> 14 | <input type="checkbox"/> 12 | <input type="checkbox"/> 17 | <input type="checkbox"/> 2 | <input type="checkbox"/> 4 | <input type="checkbox"/> 5 | <input type="checkbox"/> 1 | <input type="checkbox"/> 13 | <input type="checkbox"/> 20 | <input type="checkbox"/> 7 | <input type="checkbox"/> 11 | <input type="checkbox"/> 19 | <input type="checkbox"/> 18 | <input type="checkbox"/> 6 | <input type="checkbox"/> 15 | <input type="checkbox"/> 9 | <input type="checkbox"/> 16 | <input type="checkbox"/> 10 | <input type="checkbox"/> - | <input type="checkbox"/> - | <input type="checkbox"/> - | <input type="checkbox"/> - | <input type="checkbox"/> - | <input type="checkbox"/> - | <p>Matching answers, 26 questions, 78 points</p> <p style="text-align: center;">Code: 9506</p> <table style="width: 100%; border-collapse: collapse;"> <thead> <tr> <th style="text-align: left;">LEFT SIDE LIGHTS</th> <th style="text-align: left;">RIGHT SIDE LIGHTS</th> </tr> </thead> <tbody> <tr><td><input type="checkbox"/> 9</td><td><input type="checkbox"/> 5</td></tr> <tr><td><input type="checkbox"/> 26</td><td><input type="checkbox"/> 2</td></tr> <tr><td><input type="checkbox"/> 1</td><td><input type="checkbox"/> 25</td></tr> <tr><td><input type="checkbox"/> 23</td><td><input type="checkbox"/> 7</td></tr> <tr><td><input type="checkbox"/> 17</td><td><input type="checkbox"/> 18</td></tr> <tr><td><input type="checkbox"/> 3</td><td><input type="checkbox"/> 16</td></tr> <tr><td><input type="checkbox"/> 19</td><td><input type="checkbox"/> 8</td></tr> <tr><td><input type="checkbox"/> 12</td><td><input type="checkbox"/> 14</td></tr> <tr><td><input type="checkbox"/> 10</td><td><input type="checkbox"/> 20</td></tr> <tr><td><input type="checkbox"/> 21</td><td><input type="checkbox"/> 13</td></tr> <tr><td><input type="checkbox"/> 6</td><td><input type="checkbox"/> 22</td></tr> <tr><td><input type="checkbox"/> 24</td><td><input type="checkbox"/> 4</td></tr> <tr><td><input type="checkbox"/> 15</td><td><input type="checkbox"/> 11</td></tr> </tbody> </table> | LEFT SIDE LIGHTS | RIGHT SIDE LIGHTS | <input type="checkbox"/> 9 | <input type="checkbox"/> 5 | <input type="checkbox"/> 26 | <input type="checkbox"/> 2 | <input type="checkbox"/> 1 | <input type="checkbox"/> 25 | <input type="checkbox"/> 23 | <input type="checkbox"/> 7 | <input type="checkbox"/> 17 | <input type="checkbox"/> 18 | <input type="checkbox"/> 3 | <input type="checkbox"/> 16 | <input type="checkbox"/> 19 | <input type="checkbox"/> 8 | <input type="checkbox"/> 12 | <input type="checkbox"/> 14 | <input type="checkbox"/> 10 | <input type="checkbox"/> 20 | <input type="checkbox"/> 21 | <input type="checkbox"/> 13 | <input type="checkbox"/> 6 | <input type="checkbox"/> 22 | <input type="checkbox"/> 24 | <input type="checkbox"/> 4 | <input type="checkbox"/> 15 | <input type="checkbox"/> 11 | <p>Matching answers, 26 questions, 78 points</p> <p style="text-align: center;">Code: 9537</p> <table style="width: 100%; border-collapse: collapse;"> <thead> <tr> <th style="text-align: left;">LEFT SIDE LIGHTS</th> <th style="text-align: left;">RIGHT SIDE LIGHTS</th> </tr> </thead> <tbody> <tr><td><input type="checkbox"/> 24</td><td><input type="checkbox"/> 7</td></tr> <tr><td><input type="checkbox"/> 18</td><td><input type="checkbox"/> 12</td></tr> <tr><td><input type="checkbox"/> 20</td><td><input type="checkbox"/> 11</td></tr> <tr><td><input type="checkbox"/> 21</td><td><input type="checkbox"/> 3</td></tr> <tr><td><input type="checkbox"/> 15</td><td><input type="checkbox"/> 23</td></tr> <tr><td><input type="checkbox"/> 8</td><td><input type="checkbox"/> 9</td></tr> <tr><td><input type="checkbox"/> 1</td><td><input type="checkbox"/> 4</td></tr> <tr><td><input type="checkbox"/> 10</td><td><input type="checkbox"/> 2</td></tr> <tr><td><input type="checkbox"/> 25</td><td><input type="checkbox"/> 5</td></tr> <tr><td><input type="checkbox"/> 13</td><td><input type="checkbox"/> 26</td></tr> <tr><td><input type="checkbox"/> 19</td><td><input type="checkbox"/> 22</td></tr> <tr><td><input type="checkbox"/> 6</td><td><input type="checkbox"/> 16</td></tr> <tr><td><input type="checkbox"/> 17</td><td><input type="checkbox"/> 14</td></tr> </tbody> </table> | LEFT SIDE LIGHTS | RIGHT SIDE LIGHTS | <input type="checkbox"/> 24 | <input type="checkbox"/> 7 | <input type="checkbox"/> 18 | <input type="checkbox"/> 12 | <input type="checkbox"/> 20 | <input type="checkbox"/> 11 | <input type="checkbox"/> 21 | <input type="checkbox"/> 3 | <input type="checkbox"/> 15 | <input type="checkbox"/> 23 | <input type="checkbox"/> 8 | <input type="checkbox"/> 9 | <input type="checkbox"/> 1 | <input type="checkbox"/> 4 | <input type="checkbox"/> 10 | <input type="checkbox"/> 2 | <input type="checkbox"/> 25 | <input type="checkbox"/> 5 | <input type="checkbox"/> 13 | <input type="checkbox"/> 26 | <input type="checkbox"/> 19 | <input type="checkbox"/> 22 | <input type="checkbox"/> 6 | <input type="checkbox"/> 16 | <input type="checkbox"/> 17 | <input type="checkbox"/> 14 | | | | |
| LEFT SIDE LIGHTS | RIGHT SIDE LIGHTS | | | | | | | | | | | | | | | | | | | | | | | | | | | | | | | | | | | | | | | | | | | | | | | | | | | | | | | | | | | | | | | | | | | | | | | | | | | | | | | | | | | | | | | | | | | | | | | | | | | | | | | | | | | | | | | | | | | | | | |
| <input type="checkbox"/> 3 | <input type="checkbox"/> 18 | | | | | | | | | | | | | | | | | | | | | | | | | | | | | | | | | | | | | | | | | | | | | | | | | | | | | | | | | | | | | | | | | | | | | | | | | | | | | | | | | | | | | | | | | | | | | | | | | | | | | | | | | | | | | | | | | | | | | | |
| <input type="checkbox"/> 14 | <input type="checkbox"/> 2 | | | | | | | | | | | | | | | | | | | | | | | | | | | | | | | | | | | | | | | | | | | | | | | | | | | | | | | | | | | | | | | | | | | | | | | | | | | | | | | | | | | | | | | | | | | | | | | | | | | | | | | | | | | | | | | | | | | | | | |
| <input type="checkbox"/> 8 | <input type="checkbox"/> 10 | | | | | | | | | | | | | | | | | | | | | | | | | | | | | | | | | | | | | | | | | | | | | | | | | | | | | | | | | | | | | | | | | | | | | | | | | | | | | | | | | | | | | | | | | | | | | | | | | | | | | | | | | | | | | | | | | | | | | | |
| <input type="checkbox"/> 12 | <input type="checkbox"/> 19 | | | | | | | | | | | | | | | | | | | | | | | | | | | | | | | | | | | | | | | | | | | | | | | | | | | | | | | | | | | | | | | | | | | | | | | | | | | | | | | | | | | | | | | | | | | | | | | | | | | | | | | | | | | | | | | | | | | | | | |
| <input type="checkbox"/> 6 | <input type="checkbox"/> 1 | | | | | | | | | | | | | | | | | | | | | | | | | | | | | | | | | | | | | | | | | | | | | | | | | | | | | | | | | | | | | | | | | | | | | | | | | | | | | | | | | | | | | | | | | | | | | | | | | | | | | | | | | | | | | | | | | | | | | | |
| <input type="checkbox"/> 5 | <input type="checkbox"/> 7 | | | | | | | | | | | | | | | | | | | | | | | | | | | | | | | | | | | | | | | | | | | | | | | | | | | | | | | | | | | | | | | | | | | | | | | | | | | | | | | | | | | | | | | | | | | | | | | | | | | | | | | | | | | | | | | | | | | | | | |
| <input type="checkbox"/> 15 | <input type="checkbox"/> 11 | | | | | | | | | | | | | | | | | | | | | | | | | | | | | | | | | | | | | | | | | | | | | | | | | | | | | | | | | | | | | | | | | | | | | | | | | | | | | | | | | | | | | | | | | | | | | | | | | | | | | | | | | | | | | | | | | | | | | | |
| <input type="checkbox"/> 20 | <input type="checkbox"/> 9 | | | | | | | | | | | | | | | | | | | | | | | | | | | | | | | | | | | | | | | | | | | | | | | | | | | | | | | | | | | | | | | | | | | | | | | | | | | | | | | | | | | | | | | | | | | | | | | | | | | | | | | | | | | | | | | | | | | | | | |
| <input type="checkbox"/> 16 | <input type="checkbox"/> 13 | | | | | | | | | | | | | | | | | | | | | | | | | | | | | | | | | | | | | | | | | | | | | | | | | | | | | | | | | | | | | | | | | | | | | | | | | | | | | | | | | | | | | | | | | | | | | | | | | | | | | | | | | | | | | | | | | | | | | | |
| <input type="checkbox"/> 17 | <input type="checkbox"/> 4 | | | | | | | | | | | | | | | | | | | | | | | | | | | | | | | | | | | | | | | | | | | | | | | | | | | | | | | | | | | | | | | | | | | | | | | | | | | | | | | | | | | | | | | | | | | | | | | | | | | | | | | | | | | | | | | | | | | | | | |
| <input type="checkbox"/> - | <input type="checkbox"/> - | | | | | | | | | | | | | | | | | | | | | | | | | | | | | | | | | | | | | | | | | | | | | | | | | | | | | | | | | | | | | | | | | | | | | | | | | | | | | | | | | | | | | | | | | | | | | | | | | | | | | | | | | | | | | | | | | | | | | | |
| <input type="checkbox"/> - | <input type="checkbox"/> - | | | | | | | | | | | | | | | | | | | | | | | | | | | | | | | | | | | | | | | | | | | | | | | | | | | | | | | | | | | | | | | | | | | | | | | | | | | | | | | | | | | | | | | | | | | | | | | | | | | | | | | | | | | | | | | | | | | | | | |
| <input type="checkbox"/> - | <input type="checkbox"/> - | | | | | | | | | | | | | | | | | | | | | | | | | | | | | | | | | | | | | | | | | | | | | | | | | | | | | | | | | | | | | | | | | | | | | | | | | | | | | | | | | | | | | | | | | | | | | | | | | | | | | | | | | | | | | | | | | | | | | | |
| LEFT SIDE LIGHTS | RIGHT SIDE LIGHTS | | | | | | | | | | | | | | | | | | | | | | | | | | | | | | | | | | | | | | | | | | | | | | | | | | | | | | | | | | | | | | | | | | | | | | | | | | | | | | | | | | | | | | | | | | | | | | | | | | | | | | | | | | | | | | | | | | | | | | |
| <input type="checkbox"/> 3 | <input type="checkbox"/> 8 | | | | | | | | | | | | | | | | | | | | | | | | | | | | | | | | | | | | | | | | | | | | | | | | | | | | | | | | | | | | | | | | | | | | | | | | | | | | | | | | | | | | | | | | | | | | | | | | | | | | | | | | | | | | | | | | | | | | | | |
| <input type="checkbox"/> 14 | <input type="checkbox"/> 12 | | | | | | | | | | | | | | | | | | | | | | | | | | | | | | | | | | | | | | | | | | | | | | | | | | | | | | | | | | | | | | | | | | | | | | | | | | | | | | | | | | | | | | | | | | | | | | | | | | | | | | | | | | | | | | | | | | | | | | |
| <input type="checkbox"/> 17 | <input type="checkbox"/> 2 | | | | | | | | | | | | | | | | | | | | | | | | | | | | | | | | | | | | | | | | | | | | | | | | | | | | | | | | | | | | | | | | | | | | | | | | | | | | | | | | | | | | | | | | | | | | | | | | | | | | | | | | | | | | | | | | | | | | | | |
| <input type="checkbox"/> 4 | <input type="checkbox"/> 5 | | | | | | | | | | | | | | | | | | | | | | | | | | | | | | | | | | | | | | | | | | | | | | | | | | | | | | | | | | | | | | | | | | | | | | | | | | | | | | | | | | | | | | | | | | | | | | | | | | | | | | | | | | | | | | | | | | | | | | |
| <input type="checkbox"/> 1 | <input type="checkbox"/> 13 | | | | | | | | | | | | | | | | | | | | | | | | | | | | | | | | | | | | | | | | | | | | | | | | | | | | | | | | | | | | | | | | | | | | | | | | | | | | | | | | | | | | | | | | | | | | | | | | | | | | | | | | | | | | | | | | | | | | | | |
| <input type="checkbox"/> 20 | <input type="checkbox"/> 7 | | | | | | | | | | | | | | | | | | | | | | | | | | | | | | | | | | | | | | | | | | | | | | | | | | | | | | | | | | | | | | | | | | | | | | | | | | | | | | | | | | | | | | | | | | | | | | | | | | | | | | | | | | | | | | | | | | | | | | |
| <input type="checkbox"/> 11 | <input type="checkbox"/> 19 | | | | | | | | | | | | | | | | | | | | | | | | | | | | | | | | | | | | | | | | | | | | | | | | | | | | | | | | | | | | | | | | | | | | | | | | | | | | | | | | | | | | | | | | | | | | | | | | | | | | | | | | | | | | | | | | | | | | | | |
| <input type="checkbox"/> 18 | <input type="checkbox"/> 6 | | | | | | | | | | | | | | | | | | | | | | | | | | | | | | | | | | | | | | | | | | | | | | | | | | | | | | | | | | | | | | | | | | | | | | | | | | | | | | | | | | | | | | | | | | | | | | | | | | | | | | | | | | | | | | | | | | | | | | |
| <input type="checkbox"/> 15 | <input type="checkbox"/> 9 | | | | | | | | | | | | | | | | | | | | | | | | | | | | | | | | | | | | | | | | | | | | | | | | | | | | | | | | | | | | | | | | | | | | | | | | | | | | | | | | | | | | | | | | | | | | | | | | | | | | | | | | | | | | | | | | | | | | | | |
| <input type="checkbox"/> 16 | <input type="checkbox"/> 10 | | | | | | | | | | | | | | | | | | | | | | | | | | | | | | | | | | | | | | | | | | | | | | | | | | | | | | | | | | | | | | | | | | | | | | | | | | | | | | | | | | | | | | | | | | | | | | | | | | | | | | | | | | | | | | | | | | | | | | |
| <input type="checkbox"/> - | <input type="checkbox"/> - | | | | | | | | | | | | | | | | | | | | | | | | | | | | | | | | | | | | | | | | | | | | | | | | | | | | | | | | | | | | | | | | | | | | | | | | | | | | | | | | | | | | | | | | | | | | | | | | | | | | | | | | | | | | | | | | | | | | | | |
| <input type="checkbox"/> - | <input type="checkbox"/> - | | | | | | | | | | | | | | | | | | | | | | | | | | | | | | | | | | | | | | | | | | | | | | | | | | | | | | | | | | | | | | | | | | | | | | | | | | | | | | | | | | | | | | | | | | | | | | | | | | | | | | | | | | | | | | | | | | | | | | |
| <input type="checkbox"/> - | <input type="checkbox"/> - | | | | | | | | | | | | | | | | | | | | | | | | | | | | | | | | | | | | | | | | | | | | | | | | | | | | | | | | | | | | | | | | | | | | | | | | | | | | | | | | | | | | | | | | | | | | | | | | | | | | | | | | | | | | | | | | | | | | | | |
| LEFT SIDE LIGHTS | RIGHT SIDE LIGHTS | | | | | | | | | | | | | | | | | | | | | | | | | | | | | | | | | | | | | | | | | | | | | | | | | | | | | | | | | | | | | | | | | | | | | | | | | | | | | | | | | | | | | | | | | | | | | | | | | | | | | | | | | | | | | | | | | | | | | | |
| <input type="checkbox"/> 9 | <input type="checkbox"/> 5 | | | | | | | | | | | | | | | | | | | | | | | | | | | | | | | | | | | | | | | | | | | | | | | | | | | | | | | | | | | | | | | | | | | | | | | | | | | | | | | | | | | | | | | | | | | | | | | | | | | | | | | | | | | | | | | | | | | | | | |
| <input type="checkbox"/> 26 | <input type="checkbox"/> 2 | | | | | | | | | | | | | | | | | | | | | | | | | | | | | | | | | | | | | | | | | | | | | | | | | | | | | | | | | | | | | | | | | | | | | | | | | | | | | | | | | | | | | | | | | | | | | | | | | | | | | | | | | | | | | | | | | | | | | | |
| <input type="checkbox"/> 1 | <input type="checkbox"/> 25 | | | | | | | | | | | | | | | | | | | | | | | | | | | | | | | | | | | | | | | | | | | | | | | | | | | | | | | | | | | | | | | | | | | | | | | | | | | | | | | | | | | | | | | | | | | | | | | | | | | | | | | | | | | | | | | | | | | | | | |
| <input type="checkbox"/> 23 | <input type="checkbox"/> 7 | | | | | | | | | | | | | | | | | | | | | | | | | | | | | | | | | | | | | | | | | | | | | | | | | | | | | | | | | | | | | | | | | | | | | | | | | | | | | | | | | | | | | | | | | | | | | | | | | | | | | | | | | | | | | | | | | | | | | | |
| <input type="checkbox"/> 17 | <input type="checkbox"/> 18 | | | | | | | | | | | | | | | | | | | | | | | | | | | | | | | | | | | | | | | | | | | | | | | | | | | | | | | | | | | | | | | | | | | | | | | | | | | | | | | | | | | | | | | | | | | | | | | | | | | | | | | | | | | | | | | | | | | | | | |
| <input type="checkbox"/> 3 | <input type="checkbox"/> 16 | | | | | | | | | | | | | | | | | | | | | | | | | | | | | | | | | | | | | | | | | | | | | | | | | | | | | | | | | | | | | | | | | | | | | | | | | | | | | | | | | | | | | | | | | | | | | | | | | | | | | | | | | | | | | | | | | | | | | | |
| <input type="checkbox"/> 19 | <input type="checkbox"/> 8 | | | | | | | | | | | | | | | | | | | | | | | | | | | | | | | | | | | | | | | | | | | | | | | | | | | | | | | | | | | | | | | | | | | | | | | | | | | | | | | | | | | | | | | | | | | | | | | | | | | | | | | | | | | | | | | | | | | | | | |
| <input type="checkbox"/> 12 | <input type="checkbox"/> 14 | | | | | | | | | | | | | | | | | | | | | | | | | | | | | | | | | | | | | | | | | | | | | | | | | | | | | | | | | | | | | | | | | | | | | | | | | | | | | | | | | | | | | | | | | | | | | | | | | | | | | | | | | | | | | | | | | | | | | | |
| <input type="checkbox"/> 10 | <input type="checkbox"/> 20 | | | | | | | | | | | | | | | | | | | | | | | | | | | | | | | | | | | | | | | | | | | | | | | | | | | | | | | | | | | | | | | | | | | | | | | | | | | | | | | | | | | | | | | | | | | | | | | | | | | | | | | | | | | | | | | | | | | | | | |
| <input type="checkbox"/> 21 | <input type="checkbox"/> 13 | | | | | | | | | | | | | | | | | | | | | | | | | | | | | | | | | | | | | | | | | | | | | | | | | | | | | | | | | | | | | | | | | | | | | | | | | | | | | | | | | | | | | | | | | | | | | | | | | | | | | | | | | | | | | | | | | | | | | | |
| <input type="checkbox"/> 6 | <input type="checkbox"/> 22 | | | | | | | | | | | | | | | | | | | | | | | | | | | | | | | | | | | | | | | | | | | | | | | | | | | | | | | | | | | | | | | | | | | | | | | | | | | | | | | | | | | | | | | | | | | | | | | | | | | | | | | | | | | | | | | | | | | | | | |
| <input type="checkbox"/> 24 | <input type="checkbox"/> 4 | | | | | | | | | | | | | | | | | | | | | | | | | | | | | | | | | | | | | | | | | | | | | | | | | | | | | | | | | | | | | | | | | | | | | | | | | | | | | | | | | | | | | | | | | | | | | | | | | | | | | | | | | | | | | | | | | | | | | | |
| <input type="checkbox"/> 15 | <input type="checkbox"/> 11 | | | | | | | | | | | | | | | | | | | | | | | | | | | | | | | | | | | | | | | | | | | | | | | | | | | | | | | | | | | | | | | | | | | | | | | | | | | | | | | | | | | | | | | | | | | | | | | | | | | | | | | | | | | | | | | | | | | | | | |
| LEFT SIDE LIGHTS | RIGHT SIDE LIGHTS | | | | | | | | | | | | | | | | | | | | | | | | | | | | | | | | | | | | | | | | | | | | | | | | | | | | | | | | | | | | | | | | | | | | | | | | | | | | | | | | | | | | | | | | | | | | | | | | | | | | | | | | | | | | | | | | | | | | | | |
| <input type="checkbox"/> 24 | <input type="checkbox"/> 7 | | | | | | | | | | | | | | | | | | | | | | | | | | | | | | | | | | | | | | | | | | | | | | | | | | | | | | | | | | | | | | | | | | | | | | | | | | | | | | | | | | | | | | | | | | | | | | | | | | | | | | | | | | | | | | | | | | | | | | |
| <input type="checkbox"/> 18 | <input type="checkbox"/> 12 | | | | | | | | | | | | | | | | | | | | | | | | | | | | | | | | | | | | | | | | | | | | | | | | | | | | | | | | | | | | | | | | | | | | | | | | | | | | | | | | | | | | | | | | | | | | | | | | | | | | | | | | | | | | | | | | | | | | | | |
| <input type="checkbox"/> 20 | <input type="checkbox"/> 11 | | | | | | | | | | | | | | | | | | | | | | | | | | | | | | | | | | | | | | | | | | | | | | | | | | | | | | | | | | | | | | | | | | | | | | | | | | | | | | | | | | | | | | | | | | | | | | | | | | | | | | | | | | | | | | | | | | | | | | |
| <input type="checkbox"/> 21 | <input type="checkbox"/> 3 | | | | | | | | | | | | | | | | | | | | | | | | | | | | | | | | | | | | | | | | | | | | | | | | | | | | | | | | | | | | | | | | | | | | | | | | | | | | | | | | | | | | | | | | | | | | | | | | | | | | | | | | | | | | | | | | | | | | | | |
| <input type="checkbox"/> 15 | <input type="checkbox"/> 23 | | | | | | | | | | | | | | | | | | | | | | | | | | | | | | | | | | | | | | | | | | | | | | | | | | | | | | | | | | | | | | | | | | | | | | | | | | | | | | | | | | | | | | | | | | | | | | | | | | | | | | | | | | | | | | | | | | | | | | |
| <input type="checkbox"/> 8 | <input type="checkbox"/> 9 | | | | | | | | | | | | | | | | | | | | | | | | | | | | | | | | | | | | | | | | | | | | | | | | | | | | | | | | | | | | | | | | | | | | | | | | | | | | | | | | | | | | | | | | | | | | | | | | | | | | | | | | | | | | | | | | | | | | | | |
| <input type="checkbox"/> 1 | <input type="checkbox"/> 4 | | | | | | | | | | | | | | | | | | | | | | | | | | | | | | | | | | | | | | | | | | | | | | | | | | | | | | | | | | | | | | | | | | | | | | | | | | | | | | | | | | | | | | | | | | | | | | | | | | | | | | | | | | | | | | | | | | | | | | |
| <input type="checkbox"/> 10 | <input type="checkbox"/> 2 | | | | | | | | | | | | | | | | | | | | | | | | | | | | | | | | | | | | | | | | | | | | | | | | | | | | | | | | | | | | | | | | | | | | | | | | | | | | | | | | | | | | | | | | | | | | | | | | | | | | | | | | | | | | | | | | | | | | | | |
| <input type="checkbox"/> 25 | <input type="checkbox"/> 5 | | | | | | | | | | | | | | | | | | | | | | | | | | | | | | | | | | | | | | | | | | | | | | | | | | | | | | | | | | | | | | | | | | | | | | | | | | | | | | | | | | | | | | | | | | | | | | | | | | | | | | | | | | | | | | | | | | | | | | |
| <input type="checkbox"/> 13 | <input type="checkbox"/> 26 | | | | | | | | | | | | | | | | | | | | | | | | | | | | | | | | | | | | | | | | | | | | | | | | | | | | | | | | | | | | | | | | | | | | | | | | | | | | | | | | | | | | | | | | | | | | | | | | | | | | | | | | | | | | | | | | | | | | | | |
| <input type="checkbox"/> 19 | <input type="checkbox"/> 22 | | | | | | | | | | | | | | | | | | | | | | | | | | | | | | | | | | | | | | | | | | | | | | | | | | | | | | | | | | | | | | | | | | | | | | | | | | | | | | | | | | | | | | | | | | | | | | | | | | | | | | | | | | | | | | | | | | | | | | |
| <input type="checkbox"/> 6 | <input type="checkbox"/> 16 | | | | | | | | | | | | | | | | | | | | | | | | | | | | | | | | | | | | | | | | | | | | | | | | | | | | | | | | | | | | | | | | | | | | | | | | | | | | | | | | | | | | | | | | | | | | | | | | | | | | | | | | | | | | | | | | | | | | | | |
| <input type="checkbox"/> 17 | <input type="checkbox"/> 14 | | | | | | | | | | | | | | | | | | | | | | | | | | | | | | | | | | | | | | | | | | | | | | | | | | | | | | | | | | | | | | | | | | | | | | | | | | | | | | | | | | | | | | | | | | | | | | | | | | | | | | | | | | | | | | | | | | | | | | |

USING TWO-CHOICE ANSWER CODES

Two-choice answer codes are useful when you want answers to fall into one of two categories or would like to ask true (yes) or false (no) questions. Answers on these cards will be number keys 1 or 2 on the keyboard.

1. When writing two-choice cards, remember that not all codes allow an equal number of 1 and 2 or true and false answers. For example, a ten-question code may allow six questions for which the answer is 2 and four questions for which the answer is 1. To pick your code, note the answer for each question, and then select appropriate questions to fit that code.

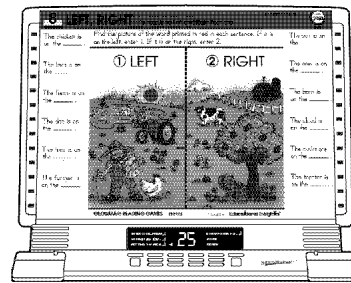

2. The middle panel of a two-answer card might have a key identifying two answers as either 1 or 2 (true/yes or false/no). Or, you may divide the middle into two panels identified as 1 and 2, as a basis for answers.
3. Divide your questions into two groups to place on the left and right sides of each card. Write each question beside its corresponding question light. The card shown above has 12 questions, divided into two groups of six. Notice how the questions are evenly spaced.

4. On a card with no numbers in the middle panel, the player would refer to the middle panel only for information and would choose one of two possible answers written below each question or as part of the instruction line. See the card on the right for an example.

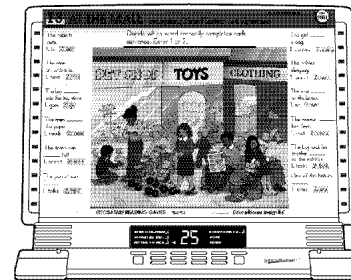

TWO-CHOICE ANSWER CODES

The answers for each of the two-choice answer codes (shown on the next page) are arranged in a pattern similar to the layout of the **GeoSafari** machine. Each dash represents a position at which there is no question. Place the corresponding answer numbers on the correct part of the illustration in the middle panel.

Two-Choice Answer Codes

| <p>Two-choice answers, 10 questions, 30 points</p> <p style="text-align: center;">Code: 1012</p> <table style="width: 100%; border-collapse: collapse;"> <thead> <tr> <th style="text-align: left;">LEFT SIDE LIGHTS</th> <th style="text-align: center;">1</th> <th style="text-align: center;">2</th> <th style="text-align: right;">RIGHT SIDE LIGHTS</th> </tr> </thead> <tbody> <tr><td><input type="checkbox"/></td><td>1</td><td>2</td><td><input type="checkbox"/></td></tr> <tr><td><input type="checkbox"/></td><td>-</td><td>-</td><td><input type="checkbox"/></td></tr> <tr><td><input type="checkbox"/></td><td>1</td><td>1</td><td><input type="checkbox"/></td></tr> <tr><td><input type="checkbox"/></td><td>-</td><td>-</td><td><input type="checkbox"/></td></tr> <tr><td><input type="checkbox"/></td><td>1</td><td>1</td><td><input type="checkbox"/></td></tr> <tr><td><input type="checkbox"/></td><td>-</td><td>-</td><td><input type="checkbox"/></td></tr> <tr><td><input type="checkbox"/></td><td>2</td><td>2</td><td><input type="checkbox"/></td></tr> <tr><td><input type="checkbox"/></td><td>-</td><td>-</td><td><input type="checkbox"/></td></tr> <tr><td><input type="checkbox"/></td><td>2</td><td>1</td><td><input type="checkbox"/></td></tr> <tr><td><input type="checkbox"/></td><td>-</td><td>-</td><td><input type="checkbox"/></td></tr> <tr><td><input type="checkbox"/></td><td>-</td><td>-</td><td><input type="checkbox"/></td></tr> <tr><td><input type="checkbox"/></td><td>-</td><td>-</td><td><input type="checkbox"/></td></tr> <tr><td><input type="checkbox"/></td><td>-</td><td>-</td><td><input type="checkbox"/></td></tr> <tr><td><input type="checkbox"/></td><td>-</td><td>-</td><td><input type="checkbox"/></td></tr> </tbody> </table> | LEFT SIDE LIGHTS | 1 | 2 | RIGHT SIDE LIGHTS | <input type="checkbox"/> | 1 | 2 | <input type="checkbox"/> | <input type="checkbox"/> | - | - | <input type="checkbox"/> | <input type="checkbox"/> | 1 | 1 | <input type="checkbox"/> | <input type="checkbox"/> | - | - | <input type="checkbox"/> | <input type="checkbox"/> | 1 | 1 | <input type="checkbox"/> | <input type="checkbox"/> | - | - | <input type="checkbox"/> | <input type="checkbox"/> | 2 | 2 | <input type="checkbox"/> | <input type="checkbox"/> | - | - | <input type="checkbox"/> | <input type="checkbox"/> | 2 | 1 | <input type="checkbox"/> | <input type="checkbox"/> | - | - | <input type="checkbox"/> | <input type="checkbox"/> | - | - | <input type="checkbox"/> | <input type="checkbox"/> | - | - | <input type="checkbox"/> | <input type="checkbox"/> | - | - | <input type="checkbox"/> | <input type="checkbox"/> | - | - | <input type="checkbox"/> | <p>Two-choice answers, 10 questions, 30 points</p> <p style="text-align: center;">Code: 1487</p> <table style="width: 100%; border-collapse: collapse;"> <thead> <tr> <th style="text-align: left;">LEFT SIDE LIGHTS</th> <th style="text-align: center;">1</th> <th style="text-align: center;">2</th> <th style="text-align: right;">RIGHT SIDE LIGHTS</th> </tr> </thead> <tbody> <tr><td><input type="checkbox"/></td><td>1</td><td>2</td><td><input type="checkbox"/></td></tr> <tr><td><input type="checkbox"/></td><td>-</td><td>-</td><td><input type="checkbox"/></td></tr> <tr><td><input type="checkbox"/></td><td>1</td><td>1</td><td><input type="checkbox"/></td></tr> <tr><td><input type="checkbox"/></td><td>-</td><td>-</td><td><input type="checkbox"/></td></tr> <tr><td><input type="checkbox"/></td><td>1</td><td>1</td><td><input type="checkbox"/></td></tr> <tr><td><input type="checkbox"/></td><td>-</td><td>-</td><td><input type="checkbox"/></td></tr> <tr><td><input type="checkbox"/></td><td>2</td><td>2</td><td><input type="checkbox"/></td></tr> <tr><td><input type="checkbox"/></td><td>-</td><td>-</td><td><input type="checkbox"/></td></tr> <tr><td><input type="checkbox"/></td><td>2</td><td>2</td><td><input type="checkbox"/></td></tr> <tr><td><input type="checkbox"/></td><td>-</td><td>-</td><td><input type="checkbox"/></td></tr> <tr><td><input type="checkbox"/></td><td>-</td><td>-</td><td><input type="checkbox"/></td></tr> <tr><td><input type="checkbox"/></td><td>-</td><td>-</td><td><input type="checkbox"/></td></tr> <tr><td><input type="checkbox"/></td><td>-</td><td>-</td><td><input type="checkbox"/></td></tr> <tr><td><input type="checkbox"/></td><td>-</td><td>-</td><td><input type="checkbox"/></td></tr> </tbody> </table> | LEFT SIDE LIGHTS | 1 | 2 | RIGHT SIDE LIGHTS | <input type="checkbox"/> | 1 | 2 | <input type="checkbox"/> | <input type="checkbox"/> | - | - | <input type="checkbox"/> | <input type="checkbox"/> | 1 | 1 | <input type="checkbox"/> | <input type="checkbox"/> | - | - | <input type="checkbox"/> | <input type="checkbox"/> | 1 | 1 | <input type="checkbox"/> | <input type="checkbox"/> | - | - | <input type="checkbox"/> | <input type="checkbox"/> | 2 | 2 | <input type="checkbox"/> | <input type="checkbox"/> | - | - | <input type="checkbox"/> | <input type="checkbox"/> | 2 | 2 | <input type="checkbox"/> | <input type="checkbox"/> | - | - | <input type="checkbox"/> | <input type="checkbox"/> | - | - | <input type="checkbox"/> | <input type="checkbox"/> | - | - | <input type="checkbox"/> | <input type="checkbox"/> | - | - | <input type="checkbox"/> | <input type="checkbox"/> | - | - | <input type="checkbox"/> | <p>Two-choice answers, 12 questions, 36 points</p> <p style="text-align: center;">Code: 2501</p> <table style="width: 100%; border-collapse: collapse;"> <thead> <tr> <th style="text-align: left;">LEFT SIDE LIGHTS</th> <th style="text-align: center;">2</th> <th style="text-align: center;">1</th> <th style="text-align: right;">RIGHT SIDE LIGHTS</th> </tr> </thead> <tbody> <tr><td><input type="checkbox"/></td><td>2</td><td>1</td><td><input type="checkbox"/></td></tr> <tr><td><input type="checkbox"/></td><td>-</td><td>-</td><td><input type="checkbox"/></td></tr> <tr><td><input type="checkbox"/></td><td>2</td><td>1</td><td><input type="checkbox"/></td></tr> <tr><td><input type="checkbox"/></td><td>-</td><td>-</td><td><input type="checkbox"/></td></tr> <tr><td><input type="checkbox"/></td><td>1</td><td>2</td><td><input type="checkbox"/></td></tr> <tr><td><input type="checkbox"/></td><td>-</td><td>-</td><td><input type="checkbox"/></td></tr> <tr><td><input type="checkbox"/></td><td>1</td><td>2</td><td><input type="checkbox"/></td></tr> <tr><td><input type="checkbox"/></td><td>-</td><td>-</td><td><input type="checkbox"/></td></tr> <tr><td><input type="checkbox"/></td><td>2</td><td>2</td><td><input type="checkbox"/></td></tr> <tr><td><input type="checkbox"/></td><td>-</td><td>-</td><td><input type="checkbox"/></td></tr> <tr><td><input type="checkbox"/></td><td>2</td><td>1</td><td><input type="checkbox"/></td></tr> <tr><td><input type="checkbox"/></td><td>-</td><td>-</td><td><input type="checkbox"/></td></tr> <tr><td><input type="checkbox"/></td><td>2</td><td>1</td><td><input type="checkbox"/></td></tr> <tr><td><input type="checkbox"/></td><td>-</td><td>-</td><td><input type="checkbox"/></td></tr> <tr><td><input type="checkbox"/></td><td>-</td><td>-</td><td><input type="checkbox"/></td></tr> </tbody> </table> | LEFT SIDE LIGHTS | 2 | 1 | RIGHT SIDE LIGHTS | <input type="checkbox"/> | 2 | 1 | <input type="checkbox"/> | <input type="checkbox"/> | - | - | <input type="checkbox"/> | <input type="checkbox"/> | 2 | 1 | <input type="checkbox"/> | <input type="checkbox"/> | - | - | <input type="checkbox"/> | <input type="checkbox"/> | 1 | 2 | <input type="checkbox"/> | <input type="checkbox"/> | - | - | <input type="checkbox"/> | <input type="checkbox"/> | 1 | 2 | <input type="checkbox"/> | <input type="checkbox"/> | - | - | <input type="checkbox"/> | <input type="checkbox"/> | 2 | 2 | <input type="checkbox"/> | <input type="checkbox"/> | - | - | <input type="checkbox"/> | <input type="checkbox"/> | 2 | 1 | <input type="checkbox"/> | <input type="checkbox"/> | - | - | <input type="checkbox"/> | <input type="checkbox"/> | 2 | 1 | <input type="checkbox"/> | <input type="checkbox"/> | - | - | <input type="checkbox"/> | <input type="checkbox"/> | - | - | <input type="checkbox"/> | <p>Two-choice answers, 12 questions, 36 points</p> <p style="text-align: center;">Code: 2950</p> <table style="width: 100%; border-collapse: collapse;"> <thead> <tr> <th style="text-align: left;">LEFT SIDE LIGHTS</th> <th style="text-align: center;">1</th> <th style="text-align: center;">1</th> <th style="text-align: right;">RIGHT SIDE LIGHTS</th> </tr> </thead> <tbody> <tr><td><input type="checkbox"/></td><td>1</td><td>1</td><td><input type="checkbox"/></td></tr> <tr><td><input type="checkbox"/></td><td>-</td><td>-</td><td><input type="checkbox"/></td></tr> <tr><td><input type="checkbox"/></td><td>1</td><td>2</td><td><input type="checkbox"/></td></tr> <tr><td><input type="checkbox"/></td><td>-</td><td>-</td><td><input type="checkbox"/></td></tr> <tr><td><input type="checkbox"/></td><td>2</td><td>2</td><td><input type="checkbox"/></td></tr> <tr><td><input type="checkbox"/></td><td>-</td><td>-</td><td><input type="checkbox"/></td></tr> <tr><td><input type="checkbox"/></td><td>2</td><td>2</td><td><input type="checkbox"/></td></tr> <tr><td><input type="checkbox"/></td><td>-</td><td>-</td><td><input type="checkbox"/></td></tr> <tr><td><input type="checkbox"/></td><td>2</td><td>1</td><td><input type="checkbox"/></td></tr> <tr><td><input type="checkbox"/></td><td>-</td><td>-</td><td><input type="checkbox"/></td></tr> <tr><td><input type="checkbox"/></td><td>1</td><td>1</td><td><input type="checkbox"/></td></tr> <tr><td><input type="checkbox"/></td><td>-</td><td>-</td><td><input type="checkbox"/></td></tr> <tr><td><input type="checkbox"/></td><td>-</td><td>-</td><td><input type="checkbox"/></td></tr> <tr><td><input type="checkbox"/></td><td>-</td><td>-</td><td><input type="checkbox"/></td></tr> </tbody> </table> | LEFT SIDE LIGHTS | 1 | 1 | RIGHT SIDE LIGHTS | <input type="checkbox"/> | 1 | 1 | <input type="checkbox"/> | <input type="checkbox"/> | - | - | <input type="checkbox"/> | <input type="checkbox"/> | 1 | 2 | <input type="checkbox"/> | <input type="checkbox"/> | - | - | <input type="checkbox"/> | <input type="checkbox"/> | 2 | 2 | <input type="checkbox"/> | <input type="checkbox"/> | - | - | <input type="checkbox"/> | <input type="checkbox"/> | 2 | 2 | <input type="checkbox"/> | <input type="checkbox"/> | - | - | <input type="checkbox"/> | <input type="checkbox"/> | 2 | 1 | <input type="checkbox"/> | <input type="checkbox"/> | - | - | <input type="checkbox"/> | <input type="checkbox"/> | 1 | 1 | <input type="checkbox"/> | <input type="checkbox"/> | - | - | <input type="checkbox"/> | <input type="checkbox"/> | - | - | <input type="checkbox"/> | <input type="checkbox"/> | - | - | <input type="checkbox"/> | | | | |
|---|------------------------|---|--------------------------|-------------------------|--------------------------|---|---|--------------------------|--------------------------|---|---|--------------------------|--------------------------|---|---|--------------------------|--------------------------|---|---|--------------------------|--------------------------|---|---|--------------------------|--------------------------|---|---|--------------------------|--------------------------|---|---|--------------------------|--------------------------|---|---|--------------------------|--------------------------|---|---|--------------------------|--------------------------|---|---|--------------------------|--------------------------|---|---|--------------------------|--------------------------|---|---|--------------------------|--------------------------|---|---|--------------------------|--------------------------|---|---|--------------------------|---|------------------------|---|--------------------------|---|--------------------------|---|---|--------------------------|--------------------------|---|---|--------------------------|--------------------------|---|---|--------------------------|--------------------------|---|---|--------------------------|--------------------------|---|---|--------------------------|--------------------------|---|---|--------------------------|--------------------------|---|---|--------------------------|--------------------------|---|---|--------------------------|--------------------------|---|---|--------------------------|--------------------------|---|---|--------------------------|--------------------------|---|---|--------------------------|--------------------------|---|---|--------------------------|--------------------------|---|---|--------------------------|--------------------------|---|---|--------------------------|---|------------------------|---|---|-------------------------|--------------------------|---|---|--------------------------|--------------------------|---|---|--------------------------|--------------------------|---|---|--------------------------|--------------------------|---|---|--------------------------|--------------------------|---|---|--------------------------|--------------------------|---|---|--------------------------|--------------------------|---|---|--------------------------|--------------------------|---|---|--------------------------|--------------------------|---|---|--------------------------|--------------------------|---|---|--------------------------|--------------------------|---|---|--------------------------|--------------------------|---|---|--------------------------|--------------------------|---|---|--------------------------|--------------------------|---|---|--------------------------|---|------------------------|---|--------------------------|---|--------------------------|---|---|--------------------------|--------------------------|---|---|--------------------------|--------------------------|---|---|--------------------------|--------------------------|---|---|--------------------------|--------------------------|---|---|--------------------------|--------------------------|---|---|--------------------------|--------------------------|---|---|--------------------------|--------------------------|---|---|--------------------------|--------------------------|---|---|--------------------------|--------------------------|---|---|--------------------------|--------------------------|---|---|--------------------------|--------------------------|---|---|--------------------------|--------------------------|---|---|--------------------------|--------------------------|---|---|--------------------------|--------------------------|---|---|--------------------------|--------------------------|---|---|--------------------------|
| LEFT SIDE LIGHTS | 1 | 2 | RIGHT SIDE LIGHTS | | | | | | | | | | | | | | | | | | | | | | | | | | | | | | | | | | | | | | | | | | | | | | | | | | | | | | | | | | | | | | | | | | | | | | | | | | | | | | | | | | | | | | | | | | | | | | | | | | | | | | | | | | | | | | | | | | | | | | | | | | | | | | | | | | | | | | | | | | | | | | | | | | | | | | | | | | | | | | | | | | | | | | | | | | | | | | | | | | | | | | | | | | | | | | | | | | | | | | | | | | | | | | | | | | | | | | | | | | | | | | | | | | | | | | | | | | | | | | | | | | | | | | | | |
| <input type="checkbox"/> | 1 | 2 | <input type="checkbox"/> | | | | | | | | | | | | | | | | | | | | | | | | | | | | | | | | | | | | | | | | | | | | | | | | | | | | | | | | | | | | | | | | | | | | | | | | | | | | | | | | | | | | | | | | | | | | | | | | | | | | | | | | | | | | | | | | | | | | | | | | | | | | | | | | | | | | | | | | | | | | | | | | | | | | | | | | | | | | | | | | | | | | | | | | | | | | | | | | | | | | | | | | | | | | | | | | | | | | | | | | | | | | | | | | | | | | | | | | | | | | | | | | | | | | | | | | | | | | | | | | | | | | | | | | |
| <input type="checkbox"/> | - | - | <input type="checkbox"/> | | | | | | | | | | | | | | | | | | | | | | | | | | | | | | | | | | | | | | | | | | | | | | | | | | | | | | | | | | | | | | | | | | | | | | | | | | | | | | | | | | | | | | | | | | | | | | | | | | | | | | | | | | | | | | | | | | | | | | | | | | | | | | | | | | | | | | | | | | | | | | | | | | | | | | | | | | | | | | | | | | | | | | | | | | | | | | | | | | | | | | | | | | | | | | | | | | | | | | | | | | | | | | | | | | | | | | | | | | | | | | | | | | | | | | | | | | | | | | | | | | | | | | | | |
| <input type="checkbox"/> | 1 | 1 | <input type="checkbox"/> | | | | | | | | | | | | | | | | | | | | | | | | | | | | | | | | | | | | | | | | | | | | | | | | | | | | | | | | | | | | | | | | | | | | | | | | | | | | | | | | | | | | | | | | | | | | | | | | | | | | | | | | | | | | | | | | | | | | | | | | | | | | | | | | | | | | | | | | | | | | | | | | | | | | | | | | | | | | | | | | | | | | | | | | | | | | | | | | | | | | | | | | | | | | | | | | | | | | | | | | | | | | | | | | | | | | | | | | | | | | | | | | | | | | | | | | | | | | | | | | | | | | | | | | |
| <input type="checkbox"/> | - | - | <input type="checkbox"/> | | | | | | | | | | | | | | | | | | | | | | | | | | | | | | | | | | | | | | | | | | | | | | | | | | | | | | | | | | | | | | | | | | | | | | | | | | | | | | | | | | | | | | | | | | | | | | | | | | | | | | | | | | | | | | | | | | | | | | | | | | | | | | | | | | | | | | | | | | | | | | | | | | | | | | | | | | | | | | | | | | | | | | | | | | | | | | | | | | | | | | | | | | | | | | | | | | | | | | | | | | | | | | | | | | | | | | | | | | | | | | | | | | | | | | | | | | | | | | | | | | | | | | | | |
| <input type="checkbox"/> | 1 | 1 | <input type="checkbox"/> | | | | | | | | | | | | | | | | | | | | | | | | | | | | | | | | | | | | | | | | | | | | | | | | | | | | | | | | | | | | | | | | | | | | | | | | | | | | | | | | | | | | | | | | | | | | | | | | | | | | | | | | | | | | | | | | | | | | | | | | | | | | | | | | | | | | | | | | | | | | | | | | | | | | | | | | | | | | | | | | | | | | | | | | | | | | | | | | | | | | | | | | | | | | | | | | | | | | | | | | | | | | | | | | | | | | | | | | | | | | | | | | | | | | | | | | | | | | | | | | | | | | | | | | |
| <input type="checkbox"/> | - | - | <input type="checkbox"/> | | | | | | | | | | | | | | | | | | | | | | | | | | | | | | | | | | | | | | | | | | | | | | | | | | | | | | | | | | | | | | | | | | | | | | | | | | | | | | | | | | | | | | | | | | | | | | | | | | | | | | | | | | | | | | | | | | | | | | | | | | | | | | | | | | | | | | | | | | | | | | | | | | | | | | | | | | | | | | | | | | | | | | | | | | | | | | | | | | | | | | | | | | | | | | | | | | | | | | | | | | | | | | | | | | | | | | | | | | | | | | | | | | | | | | | | | | | | | | | | | | | | | | | | |
| <input type="checkbox"/> | 2 | 2 | <input type="checkbox"/> | | | | | | | | | | | | | | | | | | | | | | | | | | | | | | | | | | | | | | | | | | | | | | | | | | | | | | | | | | | | | | | | | | | | | | | | | | | | | | | | | | | | | | | | | | | | | | | | | | | | | | | | | | | | | | | | | | | | | | | | | | | | | | | | | | | | | | | | | | | | | | | | | | | | | | | | | | | | | | | | | | | | | | | | | | | | | | | | | | | | | | | | | | | | | | | | | | | | | | | | | | | | | | | | | | | | | | | | | | | | | | | | | | | | | | | | | | | | | | | | | | | | | | | | |
| <input type="checkbox"/> | - | - | <input type="checkbox"/> | | | | | | | | | | | | | | | | | | | | | | | | | | | | | | | | | | | | | | | | | | | | | | | | | | | | | | | | | | | | | | | | | | | | | | | | | | | | | | | | | | | | | | | | | | | | | | | | | | | | | | | | | | | | | | | | | | | | | | | | | | | | | | | | | | | | | | | | | | | | | | | | | | | | | | | | | | | | | | | | | | | | | | | | | | | | | | | | | | | | | | | | | | | | | | | | | | | | | | | | | | | | | | | | | | | | | | | | | | | | | | | | | | | | | | | | | | | | | | | | | | | | | | | | |
| <input type="checkbox"/> | 2 | 1 | <input type="checkbox"/> | | | | | | | | | | | | | | | | | | | | | | | | | | | | | | | | | | | | | | | | | | | | | | | | | | | | | | | | | | | | | | | | | | | | | | | | | | | | | | | | | | | | | | | | | | | | | | | | | | | | | | | | | | | | | | | | | | | | | | | | | | | | | | | | | | | | | | | | | | | | | | | | | | | | | | | | | | | | | | | | | | | | | | | | | | | | | | | | | | | | | | | | | | | | | | | | | | | | | | | | | | | | | | | | | | | | | | | | | | | | | | | | | | | | | | | | | | | | | | | | | | | | | | | | |
| <input type="checkbox"/> | - | - | <input type="checkbox"/> | | | | | | | | | | | | | | | | | | | | | | | | | | | | | | | | | | | | | | | | | | | | | | | | | | | | | | | | | | | | | | | | | | | | | | | | | | | | | | | | | | | | | | | | | | | | | | | | | | | | | | | | | | | | | | | | | | | | | | | | | | | | | | | | | | | | | | | | | | | | | | | | | | | | | | | | | | | | | | | | | | | | | | | | | | | | | | | | | | | | | | | | | | | | | | | | | | | | | | | | | | | | | | | | | | | | | | | | | | | | | | | | | | | | | | | | | | | | | | | | | | | | | | | | |
| <input type="checkbox"/> | - | - | <input type="checkbox"/> | | | | | | | | | | | | | | | | | | | | | | | | | | | | | | | | | | | | | | | | | | | | | | | | | | | | | | | | | | | | | | | | | | | | | | | | | | | | | | | | | | | | | | | | | | | | | | | | | | | | | | | | | | | | | | | | | | | | | | | | | | | | | | | | | | | | | | | | | | | | | | | | | | | | | | | | | | | | | | | | | | | | | | | | | | | | | | | | | | | | | | | | | | | | | | | | | | | | | | | | | | | | | | | | | | | | | | | | | | | | | | | | | | | | | | | | | | | | | | | | | | | | | | | | |
| <input type="checkbox"/> | - | - | <input type="checkbox"/> | | | | | | | | | | | | | | | | | | | | | | | | | | | | | | | | | | | | | | | | | | | | | | | | | | | | | | | | | | | | | | | | | | | | | | | | | | | | | | | | | | | | | | | | | | | | | | | | | | | | | | | | | | | | | | | | | | | | | | | | | | | | | | | | | | | | | | | | | | | | | | | | | | | | | | | | | | | | | | | | | | | | | | | | | | | | | | | | | | | | | | | | | | | | | | | | | | | | | | | | | | | | | | | | | | | | | | | | | | | | | | | | | | | | | | | | | | | | | | | | | | | | | | | | |
| <input type="checkbox"/> | - | - | <input type="checkbox"/> | | | | | | | | | | | | | | | | | | | | | | | | | | | | | | | | | | | | | | | | | | | | | | | | | | | | | | | | | | | | | | | | | | | | | | | | | | | | | | | | | | | | | | | | | | | | | | | | | | | | | | | | | | | | | | | | | | | | | | | | | | | | | | | | | | | | | | | | | | | | | | | | | | | | | | | | | | | | | | | | | | | | | | | | | | | | | | | | | | | | | | | | | | | | | | | | | | | | | | | | | | | | | | | | | | | | | | | | | | | | | | | | | | | | | | | | | | | | | | | | | | | | | | | | |
| <input type="checkbox"/> | - | - | <input type="checkbox"/> | | | | | | | | | | | | | | | | | | | | | | | | | | | | | | | | | | | | | | | | | | | | | | | | | | | | | | | | | | | | | | | | | | | | | | | | | | | | | | | | | | | | | | | | | | | | | | | | | | | | | | | | | | | | | | | | | | | | | | | | | | | | | | | | | | | | | | | | | | | | | | | | | | | | | | | | | | | | | | | | | | | | | | | | | | | | | | | | | | | | | | | | | | | | | | | | | | | | | | | | | | | | | | | | | | | | | | | | | | | | | | | | | | | | | | | | | | | | | | | | | | | | | | | | |
| LEFT SIDE LIGHTS | 1 | 2 | RIGHT SIDE LIGHTS | | | | | | | | | | | | | | | | | | | | | | | | | | | | | | | | | | | | | | | | | | | | | | | | | | | | | | | | | | | | | | | | | | | | | | | | | | | | | | | | | | | | | | | | | | | | | | | | | | | | | | | | | | | | | | | | | | | | | | | | | | | | | | | | | | | | | | | | | | | | | | | | | | | | | | | | | | | | | | | | | | | | | | | | | | | | | | | | | | | | | | | | | | | | | | | | | | | | | | | | | | | | | | | | | | | | | | | | | | | | | | | | | | | | | | | | | | | | | | | | | | | | | | | | |
| <input type="checkbox"/> | 1 | 2 | <input type="checkbox"/> | | | | | | | | | | | | | | | | | | | | | | | | | | | | | | | | | | | | | | | | | | | | | | | | | | | | | | | | | | | | | | | | | | | | | | | | | | | | | | | | | | | | | | | | | | | | | | | | | | | | | | | | | | | | | | | | | | | | | | | | | | | | | | | | | | | | | | | | | | | | | | | | | | | | | | | | | | | | | | | | | | | | | | | | | | | | | | | | | | | | | | | | | | | | | | | | | | | | | | | | | | | | | | | | | | | | | | | | | | | | | | | | | | | | | | | | | | | | | | | | | | | | | | | | |
| <input type="checkbox"/> | - | - | <input type="checkbox"/> | | | | | | | | | | | | | | | | | | | | | | | | | | | | | | | | | | | | | | | | | | | | | | | | | | | | | | | | | | | | | | | | | | | | | | | | | | | | | | | | | | | | | | | | | | | | | | | | | | | | | | | | | | | | | | | | | | | | | | | | | | | | | | | | | | | | | | | | | | | | | | | | | | | | | | | | | | | | | | | | | | | | | | | | | | | | | | | | | | | | | | | | | | | | | | | | | | | | | | | | | | | | | | | | | | | | | | | | | | | | | | | | | | | | | | | | | | | | | | | | | | | | | | | | |
| <input type="checkbox"/> | 1 | 1 | <input type="checkbox"/> | | | | | | | | | | | | | | | | | | | | | | | | | | | | | | | | | | | | | | | | | | | | | | | | | | | | | | | | | | | | | | | | | | | | | | | | | | | | | | | | | | | | | | | | | | | | | | | | | | | | | | | | | | | | | | | | | | | | | | | | | | | | | | | | | | | | | | | | | | | | | | | | | | | | | | | | | | | | | | | | | | | | | | | | | | | | | | | | | | | | | | | | | | | | | | | | | | | | | | | | | | | | | | | | | | | | | | | | | | | | | | | | | | | | | | | | | | | | | | | | | | | | | | | | |
| <input type="checkbox"/> | - | - | <input type="checkbox"/> | | | | | | | | | | | | | | | | | | | | | | | | | | | | | | | | | | | | | | | | | | | | | | | | | | | | | | | | | | | | | | | | | | | | | | | | | | | | | | | | | | | | | | | | | | | | | | | | | | | | | | | | | | | | | | | | | | | | | | | | | | | | | | | | | | | | | | | | | | | | | | | | | | | | | | | | | | | | | | | | | | | | | | | | | | | | | | | | | | | | | | | | | | | | | | | | | | | | | | | | | | | | | | | | | | | | | | | | | | | | | | | | | | | | | | | | | | | | | | | | | | | | | | | | |
| <input type="checkbox"/> | 1 | 1 | <input type="checkbox"/> | | | | | | | | | | | | | | | | | | | | | | | | | | | | | | | | | | | | | | | | | | | | | | | | | | | | | | | | | | | | | | | | | | | | | | | | | | | | | | | | | | | | | | | | | | | | | | | | | | | | | | | | | | | | | | | | | | | | | | | | | | | | | | | | | | | | | | | | | | | | | | | | | | | | | | | | | | | | | | | | | | | | | | | | | | | | | | | | | | | | | | | | | | | | | | | | | | | | | | | | | | | | | | | | | | | | | | | | | | | | | | | | | | | | | | | | | | | | | | | | | | | | | | | | |
| <input type="checkbox"/> | - | - | <input type="checkbox"/> | | | | | | | | | | | | | | | | | | | | | | | | | | | | | | | | | | | | | | | | | | | | | | | | | | | | | | | | | | | | | | | | | | | | | | | | | | | | | | | | | | | | | | | | | | | | | | | | | | | | | | | | | | | | | | | | | | | | | | | | | | | | | | | | | | | | | | | | | | | | | | | | | | | | | | | | | | | | | | | | | | | | | | | | | | | | | | | | | | | | | | | | | | | | | | | | | | | | | | | | | | | | | | | | | | | | | | | | | | | | | | | | | | | | | | | | | | | | | | | | | | | | | | | | |
| <input type="checkbox"/> | 2 | 2 | <input type="checkbox"/> | | | | | | | | | | | | | | | | | | | | | | | | | | | | | | | | | | | | | | | | | | | | | | | | | | | | | | | | | | | | | | | | | | | | | | | | | | | | | | | | | | | | | | | | | | | | | | | | | | | | | | | | | | | | | | | | | | | | | | | | | | | | | | | | | | | | | | | | | | | | | | | | | | | | | | | | | | | | | | | | | | | | | | | | | | | | | | | | | | | | | | | | | | | | | | | | | | | | | | | | | | | | | | | | | | | | | | | | | | | | | | | | | | | | | | | | | | | | | | | | | | | | | | | | |
| <input type="checkbox"/> | - | - | <input type="checkbox"/> | | | | | | | | | | | | | | | | | | | | | | | | | | | | | | | | | | | | | | | | | | | | | | | | | | | | | | | | | | | | | | | | | | | | | | | | | | | | | | | | | | | | | | | | | | | | | | | | | | | | | | | | | | | | | | | | | | | | | | | | | | | | | | | | | | | | | | | | | | | | | | | | | | | | | | | | | | | | | | | | | | | | | | | | | | | | | | | | | | | | | | | | | | | | | | | | | | | | | | | | | | | | | | | | | | | | | | | | | | | | | | | | | | | | | | | | | | | | | | | | | | | | | | | | |
| <input type="checkbox"/> | 2 | 2 | <input type="checkbox"/> | | | | | | | | | | | | | | | | | | | | | | | | | | | | | | | | | | | | | | | | | | | | | | | | | | | | | | | | | | | | | | | | | | | | | | | | | | | | | | | | | | | | | | | | | | | | | | | | | | | | | | | | | | | | | | | | | | | | | | | | | | | | | | | | | | | | | | | | | | | | | | | | | | | | | | | | | | | | | | | | | | | | | | | | | | | | | | | | | | | | | | | | | | | | | | | | | | | | | | | | | | | | | | | | | | | | | | | | | | | | | | | | | | | | | | | | | | | | | | | | | | | | | | | | |
| <input type="checkbox"/> | - | - | <input type="checkbox"/> | | | | | | | | | | | | | | | | | | | | | | | | | | | | | | | | | | | | | | | | | | | | | | | | | | | | | | | | | | | | | | | | | | | | | | | | | | | | | | | | | | | | | | | | | | | | | | | | | | | | | | | | | | | | | | | | | | | | | | | | | | | | | | | | | | | | | | | | | | | | | | | | | | | | | | | | | | | | | | | | | | | | | | | | | | | | | | | | | | | | | | | | | | | | | | | | | | | | | | | | | | | | | | | | | | | | | | | | | | | | | | | | | | | | | | | | | | | | | | | | | | | | | | | | |
| <input type="checkbox"/> | - | - | <input type="checkbox"/> | | | | | | | | | | | | | | | | | | | | | | | | | | | | | | | | | | | | | | | | | | | | | | | | | | | | | | | | | | | | | | | | | | | | | | | | | | | | | | | | | | | | | | | | | | | | | | | | | | | | | | | | | | | | | | | | | | | | | | | | | | | | | | | | | | | | | | | | | | | | | | | | | | | | | | | | | | | | | | | | | | | | | | | | | | | | | | | | | | | | | | | | | | | | | | | | | | | | | | | | | | | | | | | | | | | | | | | | | | | | | | | | | | | | | | | | | | | | | | | | | | | | | | | | |
| <input type="checkbox"/> | - | - | <input type="checkbox"/> | | | | | | | | | | | | | | | | | | | | | | | | | | | | | | | | | | | | | | | | | | | | | | | | | | | | | | | | | | | | | | | | | | | | | | | | | | | | | | | | | | | | | | | | | | | | | | | | | | | | | | | | | | | | | | | | | | | | | | | | | | | | | | | | | | | | | | | | | | | | | | | | | | | | | | | | | | | | | | | | | | | | | | | | | | | | | | | | | | | | | | | | | | | | | | | | | | | | | | | | | | | | | | | | | | | | | | | | | | | | | | | | | | | | | | | | | | | | | | | | | | | | | | | | |
| <input type="checkbox"/> | - | - | <input type="checkbox"/> | | | | | | | | | | | | | | | | | | | | | | | | | | | | | | | | | | | | | | | | | | | | | | | | | | | | | | | | | | | | | | | | | | | | | | | | | | | | | | | | | | | | | | | | | | | | | | | | | | | | | | | | | | | | | | | | | | | | | | | | | | | | | | | | | | | | | | | | | | | | | | | | | | | | | | | | | | | | | | | | | | | | | | | | | | | | | | | | | | | | | | | | | | | | | | | | | | | | | | | | | | | | | | | | | | | | | | | | | | | | | | | | | | | | | | | | | | | | | | | | | | | | | | | | |
| <input type="checkbox"/> | - | - | <input type="checkbox"/> | | | | | | | | | | | | | | | | | | | | | | | | | | | | | | | | | | | | | | | | | | | | | | | | | | | | | | | | | | | | | | | | | | | | | | | | | | | | | | | | | | | | | | | | | | | | | | | | | | | | | | | | | | | | | | | | | | | | | | | | | | | | | | | | | | | | | | | | | | | | | | | | | | | | | | | | | | | | | | | | | | | | | | | | | | | | | | | | | | | | | | | | | | | | | | | | | | | | | | | | | | | | | | | | | | | | | | | | | | | | | | | | | | | | | | | | | | | | | | | | | | | | | | | | |
| LEFT SIDE LIGHTS | 2 | 1 | RIGHT SIDE LIGHTS | | | | | | | | | | | | | | | | | | | | | | | | | | | | | | | | | | | | | | | | | | | | | | | | | | | | | | | | | | | | | | | | | | | | | | | | | | | | | | | | | | | | | | | | | | | | | | | | | | | | | | | | | | | | | | | | | | | | | | | | | | | | | | | | | | | | | | | | | | | | | | | | | | | | | | | | | | | | | | | | | | | | | | | | | | | | | | | | | | | | | | | | | | | | | | | | | | | | | | | | | | | | | | | | | | | | | | | | | | | | | | | | | | | | | | | | | | | | | | | | | | | | | | | | |
| <input type="checkbox"/> | 2 | 1 | <input type="checkbox"/> | | | | | | | | | | | | | | | | | | | | | | | | | | | | | | | | | | | | | | | | | | | | | | | | | | | | | | | | | | | | | | | | | | | | | | | | | | | | | | | | | | | | | | | | | | | | | | | | | | | | | | | | | | | | | | | | | | | | | | | | | | | | | | | | | | | | | | | | | | | | | | | | | | | | | | | | | | | | | | | | | | | | | | | | | | | | | | | | | | | | | | | | | | | | | | | | | | | | | | | | | | | | | | | | | | | | | | | | | | | | | | | | | | | | | | | | | | | | | | | | | | | | | | | | |
| <input type="checkbox"/> | - | - | <input type="checkbox"/> | | | | | | | | | | | | | | | | | | | | | | | | | | | | | | | | | | | | | | | | | | | | | | | | | | | | | | | | | | | | | | | | | | | | | | | | | | | | | | | | | | | | | | | | | | | | | | | | | | | | | | | | | | | | | | | | | | | | | | | | | | | | | | | | | | | | | | | | | | | | | | | | | | | | | | | | | | | | | | | | | | | | | | | | | | | | | | | | | | | | | | | | | | | | | | | | | | | | | | | | | | | | | | | | | | | | | | | | | | | | | | | | | | | | | | | | | | | | | | | | | | | | | | | | |
| <input type="checkbox"/> | 2 | 1 | <input type="checkbox"/> | | | | | | | | | | | | | | | | | | | | | | | | | | | | | | | | | | | | | | | | | | | | | | | | | | | | | | | | | | | | | | | | | | | | | | | | | | | | | | | | | | | | | | | | | | | | | | | | | | | | | | | | | | | | | | | | | | | | | | | | | | | | | | | | | | | | | | | | | | | | | | | | | | | | | | | | | | | | | | | | | | | | | | | | | | | | | | | | | | | | | | | | | | | | | | | | | | | | | | | | | | | | | | | | | | | | | | | | | | | | | | | | | | | | | | | | | | | | | | | | | | | | | | | | |
| <input type="checkbox"/> | - | - | <input type="checkbox"/> | | | | | | | | | | | | | | | | | | | | | | | | | | | | | | | | | | | | | | | | | | | | | | | | | | | | | | | | | | | | | | | | | | | | | | | | | | | | | | | | | | | | | | | | | | | | | | | | | | | | | | | | | | | | | | | | | | | | | | | | | | | | | | | | | | | | | | | | | | | | | | | | | | | | | | | | | | | | | | | | | | | | | | | | | | | | | | | | | | | | | | | | | | | | | | | | | | | | | | | | | | | | | | | | | | | | | | | | | | | | | | | | | | | | | | | | | | | | | | | | | | | | | | | | |
| <input type="checkbox"/> | 1 | 2 | <input type="checkbox"/> | | | | | | | | | | | | | | | | | | | | | | | | | | | | | | | | | | | | | | | | | | | | | | | | | | | | | | | | | | | | | | | | | | | | | | | | | | | | | | | | | | | | | | | | | | | | | | | | | | | | | | | | | | | | | | | | | | | | | | | | | | | | | | | | | | | | | | | | | | | | | | | | | | | | | | | | | | | | | | | | | | | | | | | | | | | | | | | | | | | | | | | | | | | | | | | | | | | | | | | | | | | | | | | | | | | | | | | | | | | | | | | | | | | | | | | | | | | | | | | | | | | | | | | | |
| <input type="checkbox"/> | - | - | <input type="checkbox"/> | | | | | | | | | | | | | | | | | | | | | | | | | | | | | | | | | | | | | | | | | | | | | | | | | | | | | | | | | | | | | | | | | | | | | | | | | | | | | | | | | | | | | | | | | | | | | | | | | | | | | | | | | | | | | | | | | | | | | | | | | | | | | | | | | | | | | | | | | | | | | | | | | | | | | | | | | | | | | | | | | | | | | | | | | | | | | | | | | | | | | | | | | | | | | | | | | | | | | | | | | | | | | | | | | | | | | | | | | | | | | | | | | | | | | | | | | | | | | | | | | | | | | | | | |
| <input type="checkbox"/> | 1 | 2 | <input type="checkbox"/> | | | | | | | | | | | | | | | | | | | | | | | | | | | | | | | | | | | | | | | | | | | | | | | | | | | | | | | | | | | | | | | | | | | | | | | | | | | | | | | | | | | | | | | | | | | | | | | | | | | | | | | | | | | | | | | | | | | | | | | | | | | | | | | | | | | | | | | | | | | | | | | | | | | | | | | | | | | | | | | | | | | | | | | | | | | | | | | | | | | | | | | | | | | | | | | | | | | | | | | | | | | | | | | | | | | | | | | | | | | | | | | | | | | | | | | | | | | | | | | | | | | | | | | | |
| <input type="checkbox"/> | - | - | <input type="checkbox"/> | | | | | | | | | | | | | | | | | | | | | | | | | | | | | | | | | | | | | | | | | | | | | | | | | | | | | | | | | | | | | | | | | | | | | | | | | | | | | | | | | | | | | | | | | | | | | | | | | | | | | | | | | | | | | | | | | | | | | | | | | | | | | | | | | | | | | | | | | | | | | | | | | | | | | | | | | | | | | | | | | | | | | | | | | | | | | | | | | | | | | | | | | | | | | | | | | | | | | | | | | | | | | | | | | | | | | | | | | | | | | | | | | | | | | | | | | | | | | | | | | | | | | | | | |
| <input type="checkbox"/> | 2 | 2 | <input type="checkbox"/> | | | | | | | | | | | | | | | | | | | | | | | | | | | | | | | | | | | | | | | | | | | | | | | | | | | | | | | | | | | | | | | | | | | | | | | | | | | | | | | | | | | | | | | | | | | | | | | | | | | | | | | | | | | | | | | | | | | | | | | | | | | | | | | | | | | | | | | | | | | | | | | | | | | | | | | | | | | | | | | | | | | | | | | | | | | | | | | | | | | | | | | | | | | | | | | | | | | | | | | | | | | | | | | | | | | | | | | | | | | | | | | | | | | | | | | | | | | | | | | | | | | | | | | | |
| <input type="checkbox"/> | - | - | <input type="checkbox"/> | | | | | | | | | | | | | | | | | | | | | | | | | | | | | | | | | | | | | | | | | | | | | | | | | | | | | | | | | | | | | | | | | | | | | | | | | | | | | | | | | | | | | | | | | | | | | | | | | | | | | | | | | | | | | | | | | | | | | | | | | | | | | | | | | | | | | | | | | | | | | | | | | | | | | | | | | | | | | | | | | | | | | | | | | | | | | | | | | | | | | | | | | | | | | | | | | | | | | | | | | | | | | | | | | | | | | | | | | | | | | | | | | | | | | | | | | | | | | | | | | | | | | | | | |
| <input type="checkbox"/> | 2 | 1 | <input type="checkbox"/> | | | | | | | | | | | | | | | | | | | | | | | | | | | | | | | | | | | | | | | | | | | | | | | | | | | | | | | | | | | | | | | | | | | | | | | | | | | | | | | | | | | | | | | | | | | | | | | | | | | | | | | | | | | | | | | | | | | | | | | | | | | | | | | | | | | | | | | | | | | | | | | | | | | | | | | | | | | | | | | | | | | | | | | | | | | | | | | | | | | | | | | | | | | | | | | | | | | | | | | | | | | | | | | | | | | | | | | | | | | | | | | | | | | | | | | | | | | | | | | | | | | | | | | | |
| <input type="checkbox"/> | - | - | <input type="checkbox"/> | | | | | | | | | | | | | | | | | | | | | | | | | | | | | | | | | | | | | | | | | | | | | | | | | | | | | | | | | | | | | | | | | | | | | | | | | | | | | | | | | | | | | | | | | | | | | | | | | | | | | | | | | | | | | | | | | | | | | | | | | | | | | | | | | | | | | | | | | | | | | | | | | | | | | | | | | | | | | | | | | | | | | | | | | | | | | | | | | | | | | | | | | | | | | | | | | | | | | | | | | | | | | | | | | | | | | | | | | | | | | | | | | | | | | | | | | | | | | | | | | | | | | | | | |
| <input type="checkbox"/> | 2 | 1 | <input type="checkbox"/> | | | | | | | | | | | | | | | | | | | | | | | | | | | | | | | | | | | | | | | | | | | | | | | | | | | | | | | | | | | | | | | | | | | | | | | | | | | | | | | | | | | | | | | | | | | | | | | | | | | | | | | | | | | | | | | | | | | | | | | | | | | | | | | | | | | | | | | | | | | | | | | | | | | | | | | | | | | | | | | | | | | | | | | | | | | | | | | | | | | | | | | | | | | | | | | | | | | | | | | | | | | | | | | | | | | | | | | | | | | | | | | | | | | | | | | | | | | | | | | | | | | | | | | | |
| <input type="checkbox"/> | - | - | <input type="checkbox"/> | | | | | | | | | | | | | | | | | | | | | | | | | | | | | | | | | | | | | | | | | | | | | | | | | | | | | | | | | | | | | | | | | | | | | | | | | | | | | | | | | | | | | | | | | | | | | | | | | | | | | | | | | | | | | | | | | | | | | | | | | | | | | | | | | | | | | | | | | | | | | | | | | | | | | | | | | | | | | | | | | | | | | | | | | | | | | | | | | | | | | | | | | | | | | | | | | | | | | | | | | | | | | | | | | | | | | | | | | | | | | | | | | | | | | | | | | | | | | | | | | | | | | | | | |
| <input type="checkbox"/> | - | - | <input type="checkbox"/> | | | | | | | | | | | | | | | | | | | | | | | | | | | | | | | | | | | | | | | | | | | | | | | | | | | | | | | | | | | | | | | | | | | | | | | | | | | | | | | | | | | | | | | | | | | | | | | | | | | | | | | | | | | | | | | | | | | | | | | | | | | | | | | | | | | | | | | | | | | | | | | | | | | | | | | | | | | | | | | | | | | | | | | | | | | | | | | | | | | | | | | | | | | | | | | | | | | | | | | | | | | | | | | | | | | | | | | | | | | | | | | | | | | | | | | | | | | | | | | | | | | | | | | | |
| LEFT SIDE LIGHTS | 1 | 1 | RIGHT SIDE LIGHTS | | | | | | | | | | | | | | | | | | | | | | | | | | | | | | | | | | | | | | | | | | | | | | | | | | | | | | | | | | | | | | | | | | | | | | | | | | | | | | | | | | | | | | | | | | | | | | | | | | | | | | | | | | | | | | | | | | | | | | | | | | | | | | | | | | | | | | | | | | | | | | | | | | | | | | | | | | | | | | | | | | | | | | | | | | | | | | | | | | | | | | | | | | | | | | | | | | | | | | | | | | | | | | | | | | | | | | | | | | | | | | | | | | | | | | | | | | | | | | | | | | | | | | | | |
| <input type="checkbox"/> | 1 | 1 | <input type="checkbox"/> | | | | | | | | | | | | | | | | | | | | | | | | | | | | | | | | | | | | | | | | | | | | | | | | | | | | | | | | | | | | | | | | | | | | | | | | | | | | | | | | | | | | | | | | | | | | | | | | | | | | | | | | | | | | | | | | | | | | | | | | | | | | | | | | | | | | | | | | | | | | | | | | | | | | | | | | | | | | | | | | | | | | | | | | | | | | | | | | | | | | | | | | | | | | | | | | | | | | | | | | | | | | | | | | | | | | | | | | | | | | | | | | | | | | | | | | | | | | | | | | | | | | | | | | |
| <input type="checkbox"/> | - | - | <input type="checkbox"/> | | | | | | | | | | | | | | | | | | | | | | | | | | | | | | | | | | | | | | | | | | | | | | | | | | | | | | | | | | | | | | | | | | | | | | | | | | | | | | | | | | | | | | | | | | | | | | | | | | | | | | | | | | | | | | | | | | | | | | | | | | | | | | | | | | | | | | | | | | | | | | | | | | | | | | | | | | | | | | | | | | | | | | | | | | | | | | | | | | | | | | | | | | | | | | | | | | | | | | | | | | | | | | | | | | | | | | | | | | | | | | | | | | | | | | | | | | | | | | | | | | | | | | | | |
| <input type="checkbox"/> | 1 | 2 | <input type="checkbox"/> | | | | | | | | | | | | | | | | | | | | | | | | | | | | | | | | | | | | | | | | | | | | | | | | | | | | | | | | | | | | | | | | | | | | | | | | | | | | | | | | | | | | | | | | | | | | | | | | | | | | | | | | | | | | | | | | | | | | | | | | | | | | | | | | | | | | | | | | | | | | | | | | | | | | | | | | | | | | | | | | | | | | | | | | | | | | | | | | | | | | | | | | | | | | | | | | | | | | | | | | | | | | | | | | | | | | | | | | | | | | | | | | | | | | | | | | | | | | | | | | | | | | | | | | |
| <input type="checkbox"/> | - | - | <input type="checkbox"/> | | | | | | | | | | | | | | | | | | | | | | | | | | | | | | | | | | | | | | | | | | | | | | | | | | | | | | | | | | | | | | | | | | | | | | | | | | | | | | | | | | | | | | | | | | | | | | | | | | | | | | | | | | | | | | | | | | | | | | | | | | | | | | | | | | | | | | | | | | | | | | | | | | | | | | | | | | | | | | | | | | | | | | | | | | | | | | | | | | | | | | | | | | | | | | | | | | | | | | | | | | | | | | | | | | | | | | | | | | | | | | | | | | | | | | | | | | | | | | | | | | | | | | | | |
| <input type="checkbox"/> | 2 | 2 | <input type="checkbox"/> | | | | | | | | | | | | | | | | | | | | | | | | | | | | | | | | | | | | | | | | | | | | | | | | | | | | | | | | | | | | | | | | | | | | | | | | | | | | | | | | | | | | | | | | | | | | | | | | | | | | | | | | | | | | | | | | | | | | | | | | | | | | | | | | | | | | | | | | | | | | | | | | | | | | | | | | | | | | | | | | | | | | | | | | | | | | | | | | | | | | | | | | | | | | | | | | | | | | | | | | | | | | | | | | | | | | | | | | | | | | | | | | | | | | | | | | | | | | | | | | | | | | | | | | |
| <input type="checkbox"/> | - | - | <input type="checkbox"/> | | | | | | | | | | | | | | | | | | | | | | | | | | | | | | | | | | | | | | | | | | | | | | | | | | | | | | | | | | | | | | | | | | | | | | | | | | | | | | | | | | | | | | | | | | | | | | | | | | | | | | | | | | | | | | | | | | | | | | | | | | | | | | | | | | | | | | | | | | | | | | | | | | | | | | | | | | | | | | | | | | | | | | | | | | | | | | | | | | | | | | | | | | | | | | | | | | | | | | | | | | | | | | | | | | | | | | | | | | | | | | | | | | | | | | | | | | | | | | | | | | | | | | | | |
| <input type="checkbox"/> | 2 | 2 | <input type="checkbox"/> | | | | | | | | | | | | | | | | | | | | | | | | | | | | | | | | | | | | | | | | | | | | | | | | | | | | | | | | | | | | | | | | | | | | | | | | | | | | | | | | | | | | | | | | | | | | | | | | | | | | | | | | | | | | | | | | | | | | | | | | | | | | | | | | | | | | | | | | | | | | | | | | | | | | | | | | | | | | | | | | | | | | | | | | | | | | | | | | | | | | | | | | | | | | | | | | | | | | | | | | | | | | | | | | | | | | | | | | | | | | | | | | | | | | | | | | | | | | | | | | | | | | | | | | |
| <input type="checkbox"/> | - | - | <input type="checkbox"/> | | | | | | | | | | | | | | | | | | | | | | | | | | | | | | | | | | | | | | | | | | | | | | | | | | | | | | | | | | | | | | | | | | | | | | | | | | | | | | | | | | | | | | | | | | | | | | | | | | | | | | | | | | | | | | | | | | | | | | | | | | | | | | | | | | | | | | | | | | | | | | | | | | | | | | | | | | | | | | | | | | | | | | | | | | | | | | | | | | | | | | | | | | | | | | | | | | | | | | | | | | | | | | | | | | | | | | | | | | | | | | | | | | | | | | | | | | | | | | | | | | | | | | | | |
| <input type="checkbox"/> | 2 | 1 | <input type="checkbox"/> | | | | | | | | | | | | | | | | | | | | | | | | | | | | | | | | | | | | | | | | | | | | | | | | | | | | | | | | | | | | | | | | | | | | | | | | | | | | | | | | | | | | | | | | | | | | | | | | | | | | | | | | | | | | | | | | | | | | | | | | | | | | | | | | | | | | | | | | | | | | | | | | | | | | | | | | | | | | | | | | | | | | | | | | | | | | | | | | | | | | | | | | | | | | | | | | | | | | | | | | | | | | | | | | | | | | | | | | | | | | | | | | | | | | | | | | | | | | | | | | | | | | | | | | |
| <input type="checkbox"/> | - | - | <input type="checkbox"/> | | | | | | | | | | | | | | | | | | | | | | | | | | | | | | | | | | | | | | | | | | | | | | | | | | | | | | | | | | | | | | | | | | | | | | | | | | | | | | | | | | | | | | | | | | | | | | | | | | | | | | | | | | | | | | | | | | | | | | | | | | | | | | | | | | | | | | | | | | | | | | | | | | | | | | | | | | | | | | | | | | | | | | | | | | | | | | | | | | | | | | | | | | | | | | | | | | | | | | | | | | | | | | | | | | | | | | | | | | | | | | | | | | | | | | | | | | | | | | | | | | | | | | | | |
| <input type="checkbox"/> | 1 | 1 | <input type="checkbox"/> | | | | | | | | | | | | | | | | | | | | | | | | | | | | | | | | | | | | | | | | | | | | | | | | | | | | | | | | | | | | | | | | | | | | | | | | | | | | | | | | | | | | | | | | | | | | | | | | | | | | | | | | | | | | | | | | | | | | | | | | | | | | | | | | | | | | | | | | | | | | | | | | | | | | | | | | | | | | | | | | | | | | | | | | | | | | | | | | | | | | | | | | | | | | | | | | | | | | | | | | | | | | | | | | | | | | | | | | | | | | | | | | | | | | | | | | | | | | | | | | | | | | | | | | |
| <input type="checkbox"/> | - | - | <input type="checkbox"/> | | | | | | | | | | | | | | | | | | | | | | | | | | | | | | | | | | | | | | | | | | | | | | | | | | | | | | | | | | | | | | | | | | | | | | | | | | | | | | | | | | | | | | | | | | | | | | | | | | | | | | | | | | | | | | | | | | | | | | | | | | | | | | | | | | | | | | | | | | | | | | | | | | | | | | | | | | | | | | | | | | | | | | | | | | | | | | | | | | | | | | | | | | | | | | | | | | | | | | | | | | | | | | | | | | | | | | | | | | | | | | | | | | | | | | | | | | | | | | | | | | | | | | | | |
| <input type="checkbox"/> | - | - | <input type="checkbox"/> | | | | | | | | | | | | | | | | | | | | | | | | | | | | | | | | | | | | | | | | | | | | | | | | | | | | | | | | | | | | | | | | | | | | | | | | | | | | | | | | | | | | | | | | | | | | | | | | | | | | | | | | | | | | | | | | | | | | | | | | | | | | | | | | | | | | | | | | | | | | | | | | | | | | | | | | | | | | | | | | | | | | | | | | | | | | | | | | | | | | | | | | | | | | | | | | | | | | | | | | | | | | | | | | | | | | | | | | | | | | | | | | | | | | | | | | | | | | | | | | | | | | | | | | |
| <input type="checkbox"/> | - | - | <input type="checkbox"/> | | | | | | | | | | | | | | | | | | | | | | | | | | | | | | | | | | | | | | | | | | | | | | | | | | | | | | | | | | | | | | | | | | | | | | | | | | | | | | | | | | | | | | | | | | | | | | | | | | | | | | | | | | | | | | | | | | | | | | | | | | | | | | | | | | | | | | | | | | | | | | | | | | | | | | | | | | | | | | | | | | | | | | | | | | | | | | | | | | | | | | | | | | | | | | | | | | | | | | | | | | | | | | | | | | | | | | | | | | | | | | | | | | | | | | | | | | | | | | | | | | | | | | | | |
| <p>Two-choice answers, 14 questions, 42 points</p> <p style="text-align: center;">Code: 4016</p> <table style="width: 100%; border-collapse: collapse;"> <thead> <tr> <th style="text-align: left;">LEFT SIDE LIGHTS</th> <th style="text-align: center;">1</th> <th style="text-align: center;">1</th> <th style="text-align: right;">RIGHT SIDE LIGHTS</th> </tr> </thead> <tbody> <tr><td><input type="checkbox"/></td><td>1</td><td>1</td><td><input type="checkbox"/></td></tr> <tr><td><input type="checkbox"/></td><td>-</td><td>-</td><td><input type="checkbox"/></td></tr> <tr><td><input type="checkbox"/></td><td>2</td><td>1</td><td><input type="checkbox"/></td></tr> <tr><td><input type="checkbox"/></td><td>-</td><td>-</td><td><input type="checkbox"/></td></tr> <tr><td><input type="checkbox"/></td><td>2</td><td>1</td><td><input type="checkbox"/></td></tr> <tr><td><input type="checkbox"/></td><td>-</td><td>-</td><td><input type="checkbox"/></td></tr> <tr><td><input type="checkbox"/></td><td>2</td><td>2</td><td><input type="checkbox"/></td></tr> <tr><td><input type="checkbox"/></td><td>-</td><td>-</td><td><input type="checkbox"/></td></tr> <tr><td><input type="checkbox"/></td><td>2</td><td>1</td><td><input type="checkbox"/></td></tr> <tr><td><input type="checkbox"/></td><td>-</td><td>-</td><td><input type="checkbox"/></td></tr> <tr><td><input type="checkbox"/></td><td>2</td><td>1</td><td><input type="checkbox"/></td></tr> <tr><td><input type="checkbox"/></td><td>-</td><td>-</td><td><input type="checkbox"/></td></tr> <tr><td><input type="checkbox"/></td><td>1</td><td>1</td><td><input type="checkbox"/></td></tr> <tr><td><input type="checkbox"/></td><td>-</td><td>-</td><td><input type="checkbox"/></td></tr> <tr><td><input type="checkbox"/></td><td>1</td><td>1</td><td><input type="checkbox"/></td></tr> </tbody> </table> | LEFT SIDE LIGHTS | 1 | 1 | RIGHT SIDE LIGHTS | <input type="checkbox"/> | 1 | 1 | <input type="checkbox"/> | <input type="checkbox"/> | - | - | <input type="checkbox"/> | <input type="checkbox"/> | 2 | 1 | <input type="checkbox"/> | <input type="checkbox"/> | - | - | <input type="checkbox"/> | <input type="checkbox"/> | 2 | 1 | <input type="checkbox"/> | <input type="checkbox"/> | - | - | <input type="checkbox"/> | <input type="checkbox"/> | 2 | 2 | <input type="checkbox"/> | <input type="checkbox"/> | - | - | <input type="checkbox"/> | <input type="checkbox"/> | 2 | 1 | <input type="checkbox"/> | <input type="checkbox"/> | - | - | <input type="checkbox"/> | <input type="checkbox"/> | 2 | 1 | <input type="checkbox"/> | <input type="checkbox"/> | - | - | <input type="checkbox"/> | <input type="checkbox"/> | 1 | 1 | <input type="checkbox"/> | <input type="checkbox"/> | - | - | <input type="checkbox"/> | <input type="checkbox"/> | 1 | 1 | <input type="checkbox"/> | <p>Two-choice answers, 14 questions, 42 points</p> <p style="text-align: center;">Code: 4298</p> <table style="width: 100%; border-collapse: collapse;"> <thead> <tr> <th style="text-align: left;">LEFT SIDE LIGHTS</th> <th style="text-align: center;">1</th> <th style="text-align: center;">2</th> <th style="text-align: right;">RIGHT SIDE LIGHTS</th> </tr> </thead> <tbody> <tr><td><input type="checkbox"/></td><td>1</td><td>2</td><td><input type="checkbox"/></td></tr> <tr><td><input type="checkbox"/></td><td>-</td><td>-</td><td><input type="checkbox"/></td></tr> <tr><td><input type="checkbox"/></td><td>1</td><td>2</td><td><input type="checkbox"/></td></tr> <tr><td><input type="checkbox"/></td><td>-</td><td>-</td><td><input type="checkbox"/></td></tr> <tr><td><input type="checkbox"/></td><td>1</td><td>1</td><td><input type="checkbox"/></td></tr> <tr><td><input type="checkbox"/></td><td>-</td><td>-</td><td><input type="checkbox"/></td></tr> <tr><td><input type="checkbox"/></td><td>2</td><td>1</td><td><input type="checkbox"/></td></tr> <tr><td><input type="checkbox"/></td><td>-</td><td>-</td><td><input type="checkbox"/></td></tr> <tr><td><input type="checkbox"/></td><td>1</td><td>2</td><td><input type="checkbox"/></td></tr> <tr><td><input type="checkbox"/></td><td>-</td><td>-</td><td><input type="checkbox"/></td></tr> <tr><td><input type="checkbox"/></td><td>1</td><td>1</td><td><input type="checkbox"/></td></tr> <tr><td><input type="checkbox"/></td><td>-</td><td>-</td><td><input type="checkbox"/></td></tr> <tr><td><input type="checkbox"/></td><td>2</td><td>1</td><td><input type="checkbox"/></td></tr> </tbody> </table> | LEFT SIDE LIGHTS | 1 | 2 | RIGHT SIDE LIGHTS | <input type="checkbox"/> | 1 | 2 | <input type="checkbox"/> | <input type="checkbox"/> | - | - | <input type="checkbox"/> | <input type="checkbox"/> | 1 | 2 | <input type="checkbox"/> | <input type="checkbox"/> | - | - | <input type="checkbox"/> | <input type="checkbox"/> | 1 | 1 | <input type="checkbox"/> | <input type="checkbox"/> | - | - | <input type="checkbox"/> | <input type="checkbox"/> | 2 | 1 | <input type="checkbox"/> | <input type="checkbox"/> | - | - | <input type="checkbox"/> | <input type="checkbox"/> | 1 | 2 | <input type="checkbox"/> | <input type="checkbox"/> | - | - | <input type="checkbox"/> | <input type="checkbox"/> | 1 | 1 | <input type="checkbox"/> | <input type="checkbox"/> | - | - | <input type="checkbox"/> | <input type="checkbox"/> | 2 | 1 | <input type="checkbox"/> | <p>Two-choice answers, 16 questions, 48 points</p> <p style="text-align: center;">Code: 5973</p> <table style="width: 100%; border-collapse: collapse;"> <thead> <tr> <th style="text-align: left;">LEFT SIDE LIGHTS</th> <th style="text-align: center;">2</th> <th style="text-align: center;">1</th> <th style="text-align: right;">RIGHT SIDE LIGHTS</th> </tr> </thead> <tbody> <tr><td><input type="checkbox"/></td><td>2</td><td>1</td><td><input type="checkbox"/></td></tr> <tr><td><input type="checkbox"/></td><td>2</td><td>2</td><td><input type="checkbox"/></td></tr> <tr><td><input type="checkbox"/></td><td>1</td><td>1</td><td><input type="checkbox"/></td></tr> <tr><td><input type="checkbox"/></td><td>2</td><td>1</td><td><input type="checkbox"/></td></tr> <tr><td><input type="checkbox"/></td><td>1</td><td>2</td><td><input type="checkbox"/></td></tr> <tr><td><input type="checkbox"/></td><td>1</td><td>2</td><td><input type="checkbox"/></td></tr> <tr><td><input type="checkbox"/></td><td>2</td><td>1</td><td><input type="checkbox"/></td></tr> <tr><td><input type="checkbox"/></td><td>2</td><td>2</td><td><input type="checkbox"/></td></tr> <tr><td><input type="checkbox"/></td><td>-</td><td>-</td><td><input type="checkbox"/></td></tr> <tr><td><input type="checkbox"/></td><td>-</td><td>-</td><td><input type="checkbox"/></td></tr> <tr><td><input type="checkbox"/></td><td>-</td><td>-</td><td><input type="checkbox"/></td></tr> <tr><td><input type="checkbox"/></td><td>-</td><td>-</td><td><input type="checkbox"/></td></tr> <tr><td><input type="checkbox"/></td><td>-</td><td>-</td><td><input type="checkbox"/></td></tr> <tr><td><input type="checkbox"/></td><td>-</td><td>-</td><td><input type="checkbox"/></td></tr> <tr><td><input type="checkbox"/></td><td>-</td><td>-</td><td><input type="checkbox"/></td></tr> </tbody> </table> | LEFT SIDE LIGHTS | 2 | 1 | RIGHT SIDE LIGHTS | <input type="checkbox"/> | 2 | 1 | <input type="checkbox"/> | <input type="checkbox"/> | 2 | 2 | <input type="checkbox"/> | <input type="checkbox"/> | 1 | 1 | <input type="checkbox"/> | <input type="checkbox"/> | 2 | 1 | <input type="checkbox"/> | <input type="checkbox"/> | 1 | 2 | <input type="checkbox"/> | <input type="checkbox"/> | 1 | 2 | <input type="checkbox"/> | <input type="checkbox"/> | 2 | 1 | <input type="checkbox"/> | <input type="checkbox"/> | 2 | 2 | <input type="checkbox"/> | <input type="checkbox"/> | - | - | <input type="checkbox"/> | <input type="checkbox"/> | - | - | <input type="checkbox"/> | <input type="checkbox"/> | - | - | <input type="checkbox"/> | <input type="checkbox"/> | - | - | <input type="checkbox"/> | <input type="checkbox"/> | - | - | <input type="checkbox"/> | <input type="checkbox"/> | - | - | <input type="checkbox"/> | <input type="checkbox"/> | - | - | <input type="checkbox"/> | <p>Two-choice answers, 16 questions, 48 points</p> <p style="text-align: center;">Code: 5909</p> <table style="width: 100%; border-collapse: collapse;"> <thead> <tr> <th style="text-align: left;">LEFT SIDE LIGHTS</th> <th style="text-align: center;">2</th> <th style="text-align: center;">2</th> <th style="text-align: right;">RIGHT SIDE LIGHTS</th> </tr> </thead> <tbody> <tr><td><input type="checkbox"/></td><td>2</td><td>2</td><td><input type="checkbox"/></td></tr> <tr><td><input type="checkbox"/></td><td>2</td><td>2</td><td><input type="checkbox"/></td></tr> <tr><td><input type="checkbox"/></td><td>2</td><td>2</td><td><input type="checkbox"/></td></tr> <tr><td><input type="checkbox"/></td><td>1</td><td>1</td><td><input type="checkbox"/></td></tr> <tr><td><input type="checkbox"/></td><td>2</td><td>2</td><td><input type="checkbox"/></td></tr> <tr><td><input type="checkbox"/></td><td>1</td><td>1</td><td><input type="checkbox"/></td></tr> <tr><td><input type="checkbox"/></td><td>2</td><td>1</td><td><input type="checkbox"/></td></tr> <tr><td><input type="checkbox"/></td><td>1</td><td>1</td><td><input type="checkbox"/></td></tr> <tr><td><input type="checkbox"/></td><td>-</td><td>-</td><td><input type="checkbox"/></td></tr> <tr><td><input type="checkbox"/></td><td>-</td><td>-</td><td><input type="checkbox"/></td></tr> <tr><td><input type="checkbox"/></td><td>-</td><td>-</td><td><input type="checkbox"/></td></tr> <tr><td><input type="checkbox"/></td><td>-</td><td>-</td><td><input type="checkbox"/></td></tr> <tr><td><input type="checkbox"/></td><td>-</td><td>-</td><td><input type="checkbox"/></td></tr> <tr><td><input type="checkbox"/></td><td>-</td><td>-</td><td><input type="checkbox"/></td></tr> <tr><td><input type="checkbox"/></td><td>-</td><td>-</td><td><input type="checkbox"/></td></tr> </tbody> </table> | LEFT SIDE LIGHTS | 2 | 2 | RIGHT SIDE LIGHTS | <input type="checkbox"/> | 2 | 2 | <input type="checkbox"/> | <input type="checkbox"/> | 2 | 2 | <input type="checkbox"/> | <input type="checkbox"/> | 2 | 2 | <input type="checkbox"/> | <input type="checkbox"/> | 1 | 1 | <input type="checkbox"/> | <input type="checkbox"/> | 2 | 2 | <input type="checkbox"/> | <input type="checkbox"/> | 1 | 1 | <input type="checkbox"/> | <input type="checkbox"/> | 2 | 1 | <input type="checkbox"/> | <input type="checkbox"/> | 1 | 1 | <input type="checkbox"/> | <input type="checkbox"/> | - | - | <input type="checkbox"/> | <input type="checkbox"/> | - | - | <input type="checkbox"/> | <input type="checkbox"/> | - | - | <input type="checkbox"/> | <input type="checkbox"/> | - | - | <input type="checkbox"/> | <input type="checkbox"/> | - | - | <input type="checkbox"/> | <input type="checkbox"/> | - | - | <input type="checkbox"/> | <input type="checkbox"/> | - | - | <input type="checkbox"/> |
| LEFT SIDE LIGHTS | 1 | 1 | RIGHT SIDE LIGHTS | | | | | | | | | | | | | | | | | | | | | | | | | | | | | | | | | | | | | | | | | | | | | | | | | | | | | | | | | | | | | | | | | | | | | | | | | | | | | | | | | | | | | | | | | | | | | | | | | | | | | | | | | | | | | | | | | | | | | | | | | | | | | | | | | | | | | | | | | | | | | | | | | | | | | | | | | | | | | | | | | | | | | | | | | | | | | | | | | | | | | | | | | | | | | | | | | | | | | | | | | | | | | | | | | | | | | | | | | | | | | | | | | | | | | | | | | | | | | | | | | | | | | | | | |
| <input type="checkbox"/> | 1 | 1 | <input type="checkbox"/> | | | | | | | | | | | | | | | | | | | | | | | | | | | | | | | | | | | | | | | | | | | | | | | | | | | | | | | | | | | | | | | | | | | | | | | | | | | | | | | | | | | | | | | | | | | | | | | | | | | | | | | | | | | | | | | | | | | | | | | | | | | | | | | | | | | | | | | | | | | | | | | | | | | | | | | | | | | | | | | | | | | | | | | | | | | | | | | | | | | | | | | | | | | | | | | | | | | | | | | | | | | | | | | | | | | | | | | | | | | | | | | | | | | | | | | | | | | | | | | | | | | | | | | | |
| <input type="checkbox"/> | - | - | <input type="checkbox"/> | | | | | | | | | | | | | | | | | | | | | | | | | | | | | | | | | | | | | | | | | | | | | | | | | | | | | | | | | | | | | | | | | | | | | | | | | | | | | | | | | | | | | | | | | | | | | | | | | | | | | | | | | | | | | | | | | | | | | | | | | | | | | | | | | | | | | | | | | | | | | | | | | | | | | | | | | | | | | | | | | | | | | | | | | | | | | | | | | | | | | | | | | | | | | | | | | | | | | | | | | | | | | | | | | | | | | | | | | | | | | | | | | | | | | | | | | | | | | | | | | | | | | | | | |
| <input type="checkbox"/> | 2 | 1 | <input type="checkbox"/> | | | | | | | | | | | | | | | | | | | | | | | | | | | | | | | | | | | | | | | | | | | | | | | | | | | | | | | | | | | | | | | | | | | | | | | | | | | | | | | | | | | | | | | | | | | | | | | | | | | | | | | | | | | | | | | | | | | | | | | | | | | | | | | | | | | | | | | | | | | | | | | | | | | | | | | | | | | | | | | | | | | | | | | | | | | | | | | | | | | | | | | | | | | | | | | | | | | | | | | | | | | | | | | | | | | | | | | | | | | | | | | | | | | | | | | | | | | | | | | | | | | | | | | | |
| <input type="checkbox"/> | - | - | <input type="checkbox"/> | | | | | | | | | | | | | | | | | | | | | | | | | | | | | | | | | | | | | | | | | | | | | | | | | | | | | | | | | | | | | | | | | | | | | | | | | | | | | | | | | | | | | | | | | | | | | | | | | | | | | | | | | | | | | | | | | | | | | | | | | | | | | | | | | | | | | | | | | | | | | | | | | | | | | | | | | | | | | | | | | | | | | | | | | | | | | | | | | | | | | | | | | | | | | | | | | | | | | | | | | | | | | | | | | | | | | | | | | | | | | | | | | | | | | | | | | | | | | | | | | | | | | | | | |
| <input type="checkbox"/> | 2 | 1 | <input type="checkbox"/> | | | | | | | | | | | | | | | | | | | | | | | | | | | | | | | | | | | | | | | | | | | | | | | | | | | | | | | | | | | | | | | | | | | | | | | | | | | | | | | | | | | | | | | | | | | | | | | | | | | | | | | | | | | | | | | | | | | | | | | | | | | | | | | | | | | | | | | | | | | | | | | | | | | | | | | | | | | | | | | | | | | | | | | | | | | | | | | | | | | | | | | | | | | | | | | | | | | | | | | | | | | | | | | | | | | | | | | | | | | | | | | | | | | | | | | | | | | | | | | | | | | | | | | | |
| <input type="checkbox"/> | - | - | <input type="checkbox"/> | | | | | | | | | | | | | | | | | | | | | | | | | | | | | | | | | | | | | | | | | | | | | | | | | | | | | | | | | | | | | | | | | | | | | | | | | | | | | | | | | | | | | | | | | | | | | | | | | | | | | | | | | | | | | | | | | | | | | | | | | | | | | | | | | | | | | | | | | | | | | | | | | | | | | | | | | | | | | | | | | | | | | | | | | | | | | | | | | | | | | | | | | | | | | | | | | | | | | | | | | | | | | | | | | | | | | | | | | | | | | | | | | | | | | | | | | | | | | | | | | | | | | | | | |
| <input type="checkbox"/> | 2 | 2 | <input type="checkbox"/> | | | | | | | | | | | | | | | | | | | | | | | | | | | | | | | | | | | | | | | | | | | | | | | | | | | | | | | | | | | | | | | | | | | | | | | | | | | | | | | | | | | | | | | | | | | | | | | | | | | | | | | | | | | | | | | | | | | | | | | | | | | | | | | | | | | | | | | | | | | | | | | | | | | | | | | | | | | | | | | | | | | | | | | | | | | | | | | | | | | | | | | | | | | | | | | | | | | | | | | | | | | | | | | | | | | | | | | | | | | | | | | | | | | | | | | | | | | | | | | | | | | | | | | | |
| <input type="checkbox"/> | - | - | <input type="checkbox"/> | | | | | | | | | | | | | | | | | | | | | | | | | | | | | | | | | | | | | | | | | | | | | | | | | | | | | | | | | | | | | | | | | | | | | | | | | | | | | | | | | | | | | | | | | | | | | | | | | | | | | | | | | | | | | | | | | | | | | | | | | | | | | | | | | | | | | | | | | | | | | | | | | | | | | | | | | | | | | | | | | | | | | | | | | | | | | | | | | | | | | | | | | | | | | | | | | | | | | | | | | | | | | | | | | | | | | | | | | | | | | | | | | | | | | | | | | | | | | | | | | | | | | | | | |
| <input type="checkbox"/> | 2 | 1 | <input type="checkbox"/> | | | | | | | | | | | | | | | | | | | | | | | | | | | | | | | | | | | | | | | | | | | | | | | | | | | | | | | | | | | | | | | | | | | | | | | | | | | | | | | | | | | | | | | | | | | | | | | | | | | | | | | | | | | | | | | | | | | | | | | | | | | | | | | | | | | | | | | | | | | | | | | | | | | | | | | | | | | | | | | | | | | | | | | | | | | | | | | | | | | | | | | | | | | | | | | | | | | | | | | | | | | | | | | | | | | | | | | | | | | | | | | | | | | | | | | | | | | | | | | | | | | | | | | | |
| <input type="checkbox"/> | - | - | <input type="checkbox"/> | | | | | | | | | | | | | | | | | | | | | | | | | | | | | | | | | | | | | | | | | | | | | | | | | | | | | | | | | | | | | | | | | | | | | | | | | | | | | | | | | | | | | | | | | | | | | | | | | | | | | | | | | | | | | | | | | | | | | | | | | | | | | | | | | | | | | | | | | | | | | | | | | | | | | | | | | | | | | | | | | | | | | | | | | | | | | | | | | | | | | | | | | | | | | | | | | | | | | | | | | | | | | | | | | | | | | | | | | | | | | | | | | | | | | | | | | | | | | | | | | | | | | | | | |
| <input type="checkbox"/> | 2 | 1 | <input type="checkbox"/> | | | | | | | | | | | | | | | | | | | | | | | | | | | | | | | | | | | | | | | | | | | | | | | | | | | | | | | | | | | | | | | | | | | | | | | | | | | | | | | | | | | | | | | | | | | | | | | | | | | | | | | | | | | | | | | | | | | | | | | | | | | | | | | | | | | | | | | | | | | | | | | | | | | | | | | | | | | | | | | | | | | | | | | | | | | | | | | | | | | | | | | | | | | | | | | | | | | | | | | | | | | | | | | | | | | | | | | | | | | | | | | | | | | | | | | | | | | | | | | | | | | | | | | | |
| <input type="checkbox"/> | - | - | <input type="checkbox"/> | | | | | | | | | | | | | | | | | | | | | | | | | | | | | | | | | | | | | | | | | | | | | | | | | | | | | | | | | | | | | | | | | | | | | | | | | | | | | | | | | | | | | | | | | | | | | | | | | | | | | | | | | | | | | | | | | | | | | | | | | | | | | | | | | | | | | | | | | | | | | | | | | | | | | | | | | | | | | | | | | | | | | | | | | | | | | | | | | | | | | | | | | | | | | | | | | | | | | | | | | | | | | | | | | | | | | | | | | | | | | | | | | | | | | | | | | | | | | | | | | | | | | | | | |
| <input type="checkbox"/> | 1 | 1 | <input type="checkbox"/> | | | | | | | | | | | | | | | | | | | | | | | | | | | | | | | | | | | | | | | | | | | | | | | | | | | | | | | | | | | | | | | | | | | | | | | | | | | | | | | | | | | | | | | | | | | | | | | | | | | | | | | | | | | | | | | | | | | | | | | | | | | | | | | | | | | | | | | | | | | | | | | | | | | | | | | | | | | | | | | | | | | | | | | | | | | | | | | | | | | | | | | | | | | | | | | | | | | | | | | | | | | | | | | | | | | | | | | | | | | | | | | | | | | | | | | | | | | | | | | | | | | | | | | | |
| <input type="checkbox"/> | - | - | <input type="checkbox"/> | | | | | | | | | | | | | | | | | | | | | | | | | | | | | | | | | | | | | | | | | | | | | | | | | | | | | | | | | | | | | | | | | | | | | | | | | | | | | | | | | | | | | | | | | | | | | | | | | | | | | | | | | | | | | | | | | | | | | | | | | | | | | | | | | | | | | | | | | | | | | | | | | | | | | | | | | | | | | | | | | | | | | | | | | | | | | | | | | | | | | | | | | | | | | | | | | | | | | | | | | | | | | | | | | | | | | | | | | | | | | | | | | | | | | | | | | | | | | | | | | | | | | | | | |
| <input type="checkbox"/> | 1 | 1 | <input type="checkbox"/> | | | | | | | | | | | | | | | | | | | | | | | | | | | | | | | | | | | | | | | | | | | | | | | | | | | | | | | | | | | | | | | | | | | | | | | | | | | | | | | | | | | | | | | | | | | | | | | | | | | | | | | | | | | | | | | | | | | | | | | | | | | | | | | | | | | | | | | | | | | | | | | | | | | | | | | | | | | | | | | | | | | | | | | | | | | | | | | | | | | | | | | | | | | | | | | | | | | | | | | | | | | | | | | | | | | | | | | | | | | | | | | | | | | | | | | | | | | | | | | | | | | | | | | | |
| LEFT SIDE LIGHTS | 1 | 2 | RIGHT SIDE LIGHTS | | | | | | | | | | | | | | | | | | | | | | | | | | | | | | | | | | | | | | | | | | | | | | | | | | | | | | | | | | | | | | | | | | | | | | | | | | | | | | | | | | | | | | | | | | | | | | | | | | | | | | | | | | | | | | | | | | | | | | | | | | | | | | | | | | | | | | | | | | | | | | | | | | | | | | | | | | | | | | | | | | | | | | | | | | | | | | | | | | | | | | | | | | | | | | | | | | | | | | | | | | | | | | | | | | | | | | | | | | | | | | | | | | | | | | | | | | | | | | | | | | | | | | | | |
| <input type="checkbox"/> | 1 | 2 | <input type="checkbox"/> | | | | | | | | | | | | | | | | | | | | | | | | | | | | | | | | | | | | | | | | | | | | | | | | | | | | | | | | | | | | | | | | | | | | | | | | | | | | | | | | | | | | | | | | | | | | | | | | | | | | | | | | | | | | | | | | | | | | | | | | | | | | | | | | | | | | | | | | | | | | | | | | | | | | | | | | | | | | | | | | | | | | | | | | | | | | | | | | | | | | | | | | | | | | | | | | | | | | | | | | | | | | | | | | | | | | | | | | | | | | | | | | | | | | | | | | | | | | | | | | | | | | | | | | |
| <input type="checkbox"/> | - | - | <input type="checkbox"/> | | | | | | | | | | | | | | | | | | | | | | | | | | | | | | | | | | | | | | | | | | | | | | | | | | | | | | | | | | | | | | | | | | | | | | | | | | | | | | | | | | | | | | | | | | | | | | | | | | | | | | | | | | | | | | | | | | | | | | | | | | | | | | | | | | | | | | | | | | | | | | | | | | | | | | | | | | | | | | | | | | | | | | | | | | | | | | | | | | | | | | | | | | | | | | | | | | | | | | | | | | | | | | | | | | | | | | | | | | | | | | | | | | | | | | | | | | | | | | | | | | | | | | | | |
| <input type="checkbox"/> | 1 | 2 | <input type="checkbox"/> | | | | | | | | | | | | | | | | | | | | | | | | | | | | | | | | | | | | | | | | | | | | | | | | | | | | | | | | | | | | | | | | | | | | | | | | | | | | | | | | | | | | | | | | | | | | | | | | | | | | | | | | | | | | | | | | | | | | | | | | | | | | | | | | | | | | | | | | | | | | | | | | | | | | | | | | | | | | | | | | | | | | | | | | | | | | | | | | | | | | | | | | | | | | | | | | | | | | | | | | | | | | | | | | | | | | | | | | | | | | | | | | | | | | | | | | | | | | | | | | | | | | | | | | |
| <input type="checkbox"/> | - | - | <input type="checkbox"/> | | | | | | | | | | | | | | | | | | | | | | | | | | | | | | | | | | | | | | | | | | | | | | | | | | | | | | | | | | | | | | | | | | | | | | | | | | | | | | | | | | | | | | | | | | | | | | | | | | | | | | | | | | | | | | | | | | | | | | | | | | | | | | | | | | | | | | | | | | | | | | | | | | | | | | | | | | | | | | | | | | | | | | | | | | | | | | | | | | | | | | | | | | | | | | | | | | | | | | | | | | | | | | | | | | | | | | | | | | | | | | | | | | | | | | | | | | | | | | | | | | | | | | | | |
| <input type="checkbox"/> | 1 | 1 | <input type="checkbox"/> | | | | | | | | | | | | | | | | | | | | | | | | | | | | | | | | | | | | | | | | | | | | | | | | | | | | | | | | | | | | | | | | | | | | | | | | | | | | | | | | | | | | | | | | | | | | | | | | | | | | | | | | | | | | | | | | | | | | | | | | | | | | | | | | | | | | | | | | | | | | | | | | | | | | | | | | | | | | | | | | | | | | | | | | | | | | | | | | | | | | | | | | | | | | | | | | | | | | | | | | | | | | | | | | | | | | | | | | | | | | | | | | | | | | | | | | | | | | | | | | | | | | | | | | |
| <input type="checkbox"/> | - | - | <input type="checkbox"/> | | | | | | | | | | | | | | | | | | | | | | | | | | | | | | | | | | | | | | | | | | | | | | | | | | | | | | | | | | | | | | | | | | | | | | | | | | | | | | | | | | | | | | | | | | | | | | | | | | | | | | | | | | | | | | | | | | | | | | | | | | | | | | | | | | | | | | | | | | | | | | | | | | | | | | | | | | | | | | | | | | | | | | | | | | | | | | | | | | | | | | | | | | | | | | | | | | | | | | | | | | | | | | | | | | | | | | | | | | | | | | | | | | | | | | | | | | | | | | | | | | | | | | | | |
| <input type="checkbox"/> | 2 | 1 | <input type="checkbox"/> | | | | | | | | | | | | | | | | | | | | | | | | | | | | | | | | | | | | | | | | | | | | | | | | | | | | | | | | | | | | | | | | | | | | | | | | | | | | | | | | | | | | | | | | | | | | | | | | | | | | | | | | | | | | | | | | | | | | | | | | | | | | | | | | | | | | | | | | | | | | | | | | | | | | | | | | | | | | | | | | | | | | | | | | | | | | | | | | | | | | | | | | | | | | | | | | | | | | | | | | | | | | | | | | | | | | | | | | | | | | | | | | | | | | | | | | | | | | | | | | | | | | | | | | |
| <input type="checkbox"/> | - | - | <input type="checkbox"/> | | | | | | | | | | | | | | | | | | | | | | | | | | | | | | | | | | | | | | | | | | | | | | | | | | | | | | | | | | | | | | | | | | | | | | | | | | | | | | | | | | | | | | | | | | | | | | | | | | | | | | | | | | | | | | | | | | | | | | | | | | | | | | | | | | | | | | | | | | | | | | | | | | | | | | | | | | | | | | | | | | | | | | | | | | | | | | | | | | | | | | | | | | | | | | | | | | | | | | | | | | | | | | | | | | | | | | | | | | | | | | | | | | | | | | | | | | | | | | | | | | | | | | | | |
| <input type="checkbox"/> | 1 | 2 | <input type="checkbox"/> | | | | | | | | | | | | | | | | | | | | | | | | | | | | | | | | | | | | | | | | | | | | | | | | | | | | | | | | | | | | | | | | | | | | | | | | | | | | | | | | | | | | | | | | | | | | | | | | | | | | | | | | | | | | | | | | | | | | | | | | | | | | | | | | | | | | | | | | | | | | | | | | | | | | | | | | | | | | | | | | | | | | | | | | | | | | | | | | | | | | | | | | | | | | | | | | | | | | | | | | | | | | | | | | | | | | | | | | | | | | | | | | | | | | | | | | | | | | | | | | | | | | | | | | |
| <input type="checkbox"/> | - | - | <input type="checkbox"/> | | | | | | | | | | | | | | | | | | | | | | | | | | | | | | | | | | | | | | | | | | | | | | | | | | | | | | | | | | | | | | | | | | | | | | | | | | | | | | | | | | | | | | | | | | | | | | | | | | | | | | | | | | | | | | | | | | | | | | | | | | | | | | | | | | | | | | | | | | | | | | | | | | | | | | | | | | | | | | | | | | | | | | | | | | | | | | | | | | | | | | | | | | | | | | | | | | | | | | | | | | | | | | | | | | | | | | | | | | | | | | | | | | | | | | | | | | | | | | | | | | | | | | | | |
| <input type="checkbox"/> | 1 | 1 | <input type="checkbox"/> | | | | | | | | | | | | | | | | | | | | | | | | | | | | | | | | | | | | | | | | | | | | | | | | | | | | | | | | | | | | | | | | | | | | | | | | | | | | | | | | | | | | | | | | | | | | | | | | | | | | | | | | | | | | | | | | | | | | | | | | | | | | | | | | | | | | | | | | | | | | | | | | | | | | | | | | | | | | | | | | | | | | | | | | | | | | | | | | | | | | | | | | | | | | | | | | | | | | | | | | | | | | | | | | | | | | | | | | | | | | | | | | | | | | | | | | | | | | | | | | | | | | | | | | |
| <input type="checkbox"/> | - | - | <input type="checkbox"/> | | | | | | | | | | | | | | | | | | | | | | | | | | | | | | | | | | | | | | | | | | | | | | | | | | | | | | | | | | | | | | | | | | | | | | | | | | | | | | | | | | | | | | | | | | | | | | | | | | | | | | | | | | | | | | | | | | | | | | | | | | | | | | | | | | | | | | | | | | | | | | | | | | | | | | | | | | | | | | | | | | | | | | | | | | | | | | | | | | | | | | | | | | | | | | | | | | | | | | | | | | | | | | | | | | | | | | | | | | | | | | | | | | | | | | | | | | | | | | | | | | | | | | | | |
| <input type="checkbox"/> | 2 | 1 | <input type="checkbox"/> | | | | | | | | | | | | | | | | | | | | | | | | | | | | | | | | | | | | | | | | | | | | | | | | | | | | | | | | | | | | | | | | | | | | | | | | | | | | | | | | | | | | | | | | | | | | | | | | | | | | | | | | | | | | | | | | | | | | | | | | | | | | | | | | | | | | | | | | | | | | | | | | | | | | | | | | | | | | | | | | | | | | | | | | | | | | | | | | | | | | | | | | | | | | | | | | | | | | | | | | | | | | | | | | | | | | | | | | | | | | | | | | | | | | | | | | | | | | | | | | | | | | | | | | |
| LEFT SIDE LIGHTS | 2 | 1 | RIGHT SIDE LIGHTS | | | | | | | | | | | | | | | | | | | | | | | | | | | | | | | | | | | | | | | | | | | | | | | | | | | | | | | | | | | | | | | | | | | | | | | | | | | | | | | | | | | | | | | | | | | | | | | | | | | | | | | | | | | | | | | | | | | | | | | | | | | | | | | | | | | | | | | | | | | | | | | | | | | | | | | | | | | | | | | | | | | | | | | | | | | | | | | | | | | | | | | | | | | | | | | | | | | | | | | | | | | | | | | | | | | | | | | | | | | | | | | | | | | | | | | | | | | | | | | | | | | | | | | | |
| <input type="checkbox"/> | 2 | 1 | <input type="checkbox"/> | | | | | | | | | | | | | | | | | | | | | | | | | | | | | | | | | | | | | | | | | | | | | | | | | | | | | | | | | | | | | | | | | | | | | | | | | | | | | | | | | | | | | | | | | | | | | | | | | | | | | | | | | | | | | | | | | | | | | | | | | | | | | | | | | | | | | | | | | | | | | | | | | | | | | | | | | | | | | | | | | | | | | | | | | | | | | | | | | | | | | | | | | | | | | | | | | | | | | | | | | | | | | | | | | | | | | | | | | | | | | | | | | | | | | | | | | | | | | | | | | | | | | | | | |
| <input type="checkbox"/> | 2 | 2 | <input type="checkbox"/> | | | | | | | | | | | | | | | | | | | | | | | | | | | | | | | | | | | | | | | | | | | | | | | | | | | | | | | | | | | | | | | | | | | | | | | | | | | | | | | | | | | | | | | | | | | | | | | | | | | | | | | | | | | | | | | | | | | | | | | | | | | | | | | | | | | | | | | | | | | | | | | | | | | | | | | | | | | | | | | | | | | | | | | | | | | | | | | | | | | | | | | | | | | | | | | | | | | | | | | | | | | | | | | | | | | | | | | | | | | | | | | | | | | | | | | | | | | | | | | | | | | | | | | | |
| <input type="checkbox"/> | 1 | 1 | <input type="checkbox"/> | | | | | | | | | | | | | | | | | | | | | | | | | | | | | | | | | | | | | | | | | | | | | | | | | | | | | | | | | | | | | | | | | | | | | | | | | | | | | | | | | | | | | | | | | | | | | | | | | | | | | | | | | | | | | | | | | | | | | | | | | | | | | | | | | | | | | | | | | | | | | | | | | | | | | | | | | | | | | | | | | | | | | | | | | | | | | | | | | | | | | | | | | | | | | | | | | | | | | | | | | | | | | | | | | | | | | | | | | | | | | | | | | | | | | | | | | | | | | | | | | | | | | | | | |
| <input type="checkbox"/> | 2 | 1 | <input type="checkbox"/> | | | | | | | | | | | | | | | | | | | | | | | | | | | | | | | | | | | | | | | | | | | | | | | | | | | | | | | | | | | | | | | | | | | | | | | | | | | | | | | | | | | | | | | | | | | | | | | | | | | | | | | | | | | | | | | | | | | | | | | | | | | | | | | | | | | | | | | | | | | | | | | | | | | | | | | | | | | | | | | | | | | | | | | | | | | | | | | | | | | | | | | | | | | | | | | | | | | | | | | | | | | | | | | | | | | | | | | | | | | | | | | | | | | | | | | | | | | | | | | | | | | | | | | | |
| <input type="checkbox"/> | 1 | 2 | <input type="checkbox"/> | | | | | | | | | | | | | | | | | | | | | | | | | | | | | | | | | | | | | | | | | | | | | | | | | | | | | | | | | | | | | | | | | | | | | | | | | | | | | | | | | | | | | | | | | | | | | | | | | | | | | | | | | | | | | | | | | | | | | | | | | | | | | | | | | | | | | | | | | | | | | | | | | | | | | | | | | | | | | | | | | | | | | | | | | | | | | | | | | | | | | | | | | | | | | | | | | | | | | | | | | | | | | | | | | | | | | | | | | | | | | | | | | | | | | | | | | | | | | | | | | | | | | | | | |
| <input type="checkbox"/> | 1 | 2 | <input type="checkbox"/> | | | | | | | | | | | | | | | | | | | | | | | | | | | | | | | | | | | | | | | | | | | | | | | | | | | | | | | | | | | | | | | | | | | | | | | | | | | | | | | | | | | | | | | | | | | | | | | | | | | | | | | | | | | | | | | | | | | | | | | | | | | | | | | | | | | | | | | | | | | | | | | | | | | | | | | | | | | | | | | | | | | | | | | | | | | | | | | | | | | | | | | | | | | | | | | | | | | | | | | | | | | | | | | | | | | | | | | | | | | | | | | | | | | | | | | | | | | | | | | | | | | | | | | | |
| <input type="checkbox"/> | 2 | 1 | <input type="checkbox"/> | | | | | | | | | | | | | | | | | | | | | | | | | | | | | | | | | | | | | | | | | | | | | | | | | | | | | | | | | | | | | | | | | | | | | | | | | | | | | | | | | | | | | | | | | | | | | | | | | | | | | | | | | | | | | | | | | | | | | | | | | | | | | | | | | | | | | | | | | | | | | | | | | | | | | | | | | | | | | | | | | | | | | | | | | | | | | | | | | | | | | | | | | | | | | | | | | | | | | | | | | | | | | | | | | | | | | | | | | | | | | | | | | | | | | | | | | | | | | | | | | | | | | | | | |
| <input type="checkbox"/> | 2 | 2 | <input type="checkbox"/> | | | | | | | | | | | | | | | | | | | | | | | | | | | | | | | | | | | | | | | | | | | | | | | | | | | | | | | | | | | | | | | | | | | | | | | | | | | | | | | | | | | | | | | | | | | | | | | | | | | | | | | | | | | | | | | | | | | | | | | | | | | | | | | | | | | | | | | | | | | | | | | | | | | | | | | | | | | | | | | | | | | | | | | | | | | | | | | | | | | | | | | | | | | | | | | | | | | | | | | | | | | | | | | | | | | | | | | | | | | | | | | | | | | | | | | | | | | | | | | | | | | | | | | | |
| <input type="checkbox"/> | - | - | <input type="checkbox"/> | | | | | | | | | | | | | | | | | | | | | | | | | | | | | | | | | | | | | | | | | | | | | | | | | | | | | | | | | | | | | | | | | | | | | | | | | | | | | | | | | | | | | | | | | | | | | | | | | | | | | | | | | | | | | | | | | | | | | | | | | | | | | | | | | | | | | | | | | | | | | | | | | | | | | | | | | | | | | | | | | | | | | | | | | | | | | | | | | | | | | | | | | | | | | | | | | | | | | | | | | | | | | | | | | | | | | | | | | | | | | | | | | | | | | | | | | | | | | | | | | | | | | | | | |
| <input type="checkbox"/> | - | - | <input type="checkbox"/> | | | | | | | | | | | | | | | | | | | | | | | | | | | | | | | | | | | | | | | | | | | | | | | | | | | | | | | | | | | | | | | | | | | | | | | | | | | | | | | | | | | | | | | | | | | | | | | | | | | | | | | | | | | | | | | | | | | | | | | | | | | | | | | | | | | | | | | | | | | | | | | | | | | | | | | | | | | | | | | | | | | | | | | | | | | | | | | | | | | | | | | | | | | | | | | | | | | | | | | | | | | | | | | | | | | | | | | | | | | | | | | | | | | | | | | | | | | | | | | | | | | | | | | | |
| <input type="checkbox"/> | - | - | <input type="checkbox"/> | | | | | | | | | | | | | | | | | | | | | | | | | | | | | | | | | | | | | | | | | | | | | | | | | | | | | | | | | | | | | | | | | | | | | | | | | | | | | | | | | | | | | | | | | | | | | | | | | | | | | | | | | | | | | | | | | | | | | | | | | | | | | | | | | | | | | | | | | | | | | | | | | | | | | | | | | | | | | | | | | | | | | | | | | | | | | | | | | | | | | | | | | | | | | | | | | | | | | | | | | | | | | | | | | | | | | | | | | | | | | | | | | | | | | | | | | | | | | | | | | | | | | | | | |
| <input type="checkbox"/> | - | - | <input type="checkbox"/> | | | | | | | | | | | | | | | | | | | | | | | | | | | | | | | | | | | | | | | | | | | | | | | | | | | | | | | | | | | | | | | | | | | | | | | | | | | | | | | | | | | | | | | | | | | | | | | | | | | | | | | | | | | | | | | | | | | | | | | | | | | | | | | | | | | | | | | | | | | | | | | | | | | | | | | | | | | | | | | | | | | | | | | | | | | | | | | | | | | | | | | | | | | | | | | | | | | | | | | | | | | | | | | | | | | | | | | | | | | | | | | | | | | | | | | | | | | | | | | | | | | | | | | | |
| <input type="checkbox"/> | - | - | <input type="checkbox"/> | | | | | | | | | | | | | | | | | | | | | | | | | | | | | | | | | | | | | | | | | | | | | | | | | | | | | | | | | | | | | | | | | | | | | | | | | | | | | | | | | | | | | | | | | | | | | | | | | | | | | | | | | | | | | | | | | | | | | | | | | | | | | | | | | | | | | | | | | | | | | | | | | | | | | | | | | | | | | | | | | | | | | | | | | | | | | | | | | | | | | | | | | | | | | | | | | | | | | | | | | | | | | | | | | | | | | | | | | | | | | | | | | | | | | | | | | | | | | | | | | | | | | | | | |
| <input type="checkbox"/> | - | - | <input type="checkbox"/> | | | | | | | | | | | | | | | | | | | | | | | | | | | | | | | | | | | | | | | | | | | | | | | | | | | | | | | | | | | | | | | | | | | | | | | | | | | | | | | | | | | | | | | | | | | | | | | | | | | | | | | | | | | | | | | | | | | | | | | | | | | | | | | | | | | | | | | | | | | | | | | | | | | | | | | | | | | | | | | | | | | | | | | | | | | | | | | | | | | | | | | | | | | | | | | | | | | | | | | | | | | | | | | | | | | | | | | | | | | | | | | | | | | | | | | | | | | | | | | | | | | | | | | | |
| <input type="checkbox"/> | - | - | <input type="checkbox"/> | | | | | | | | | | | | | | | | | | | | | | | | | | | | | | | | | | | | | | | | | | | | | | | | | | | | | | | | | | | | | | | | | | | | | | | | | | | | | | | | | | | | | | | | | | | | | | | | | | | | | | | | | | | | | | | | | | | | | | | | | | | | | | | | | | | | | | | | | | | | | | | | | | | | | | | | | | | | | | | | | | | | | | | | | | | | | | | | | | | | | | | | | | | | | | | | | | | | | | | | | | | | | | | | | | | | | | | | | | | | | | | | | | | | | | | | | | | | | | | | | | | | | | | | |
| LEFT SIDE LIGHTS | 2 | 2 | RIGHT SIDE LIGHTS | | | | | | | | | | | | | | | | | | | | | | | | | | | | | | | | | | | | | | | | | | | | | | | | | | | | | | | | | | | | | | | | | | | | | | | | | | | | | | | | | | | | | | | | | | | | | | | | | | | | | | | | | | | | | | | | | | | | | | | | | | | | | | | | | | | | | | | | | | | | | | | | | | | | | | | | | | | | | | | | | | | | | | | | | | | | | | | | | | | | | | | | | | | | | | | | | | | | | | | | | | | | | | | | | | | | | | | | | | | | | | | | | | | | | | | | | | | | | | | | | | | | | | | | |
| <input type="checkbox"/> | 2 | 2 | <input type="checkbox"/> | | | | | | | | | | | | | | | | | | | | | | | | | | | | | | | | | | | | | | | | | | | | | | | | | | | | | | | | | | | | | | | | | | | | | | | | | | | | | | | | | | | | | | | | | | | | | | | | | | | | | | | | | | | | | | | | | | | | | | | | | | | | | | | | | | | | | | | | | | | | | | | | | | | | | | | | | | | | | | | | | | | | | | | | | | | | | | | | | | | | | | | | | | | | | | | | | | | | | | | | | | | | | | | | | | | | | | | | | | | | | | | | | | | | | | | | | | | | | | | | | | | | | | | | |
| <input type="checkbox"/> | 2 | 2 | <input type="checkbox"/> | | | | | | | | | | | | | | | | | | | | | | | | | | | | | | | | | | | | | | | | | | | | | | | | | | | | | | | | | | | | | | | | | | | | | | | | | | | | | | | | | | | | | | | | | | | | | | | | | | | | | | | | | | | | | | | | | | | | | | | | | | | | | | | | | | | | | | | | | | | | | | | | | | | | | | | | | | | | | | | | | | | | | | | | | | | | | | | | | | | | | | | | | | | | | | | | | | | | | | | | | | | | | | | | | | | | | | | | | | | | | | | | | | | | | | | | | | | | | | | | | | | | | | | | |
| <input type="checkbox"/> | 2 | 2 | <input type="checkbox"/> | | | | | | | | | | | | | | | | | | | | | | | | | | | | | | | | | | | | | | | | | | | | | | | | | | | | | | | | | | | | | | | | | | | | | | | | | | | | | | | | | | | | | | | | | | | | | | | | | | | | | | | | | | | | | | | | | | | | | | | | | | | | | | | | | | | | | | | | | | | | | | | | | | | | | | | | | | | | | | | | | | | | | | | | | | | | | | | | | | | | | | | | | | | | | | | | | | | | | | | | | | | | | | | | | | | | | | | | | | | | | | | | | | | | | | | | | | | | | | | | | | | | | | | | |
| <input type="checkbox"/> | 1 | 1 | <input type="checkbox"/> | | | | | | | | | | | | | | | | | | | | | | | | | | | | | | | | | | | | | | | | | | | | | | | | | | | | | | | | | | | | | | | | | | | | | | | | | | | | | | | | | | | | | | | | | | | | | | | | | | | | | | | | | | | | | | | | | | | | | | | | | | | | | | | | | | | | | | | | | | | | | | | | | | | | | | | | | | | | | | | | | | | | | | | | | | | | | | | | | | | | | | | | | | | | | | | | | | | | | | | | | | | | | | | | | | | | | | | | | | | | | | | | | | | | | | | | | | | | | | | | | | | | | | | | |
| <input type="checkbox"/> | 2 | 2 | <input type="checkbox"/> | | | | | | | | | | | | | | | | | | | | | | | | | | | | | | | | | | | | | | | | | | | | | | | | | | | | | | | | | | | | | | | | | | | | | | | | | | | | | | | | | | | | | | | | | | | | | | | | | | | | | | | | | | | | | | | | | | | | | | | | | | | | | | | | | | | | | | | | | | | | | | | | | | | | | | | | | | | | | | | | | | | | | | | | | | | | | | | | | | | | | | | | | | | | | | | | | | | | | | | | | | | | | | | | | | | | | | | | | | | | | | | | | | | | | | | | | | | | | | | | | | | | | | | | |
| <input type="checkbox"/> | 1 | 1 | <input type="checkbox"/> | | | | | | | | | | | | | | | | | | | | | | | | | | | | | | | | | | | | | | | | | | | | | | | | | | | | | | | | | | | | | | | | | | | | | | | | | | | | | | | | | | | | | | | | | | | | | | | | | | | | | | | | | | | | | | | | | | | | | | | | | | | | | | | | | | | | | | | | | | | | | | | | | | | | | | | | | | | | | | | | | | | | | | | | | | | | | | | | | | | | | | | | | | | | | | | | | | | | | | | | | | | | | | | | | | | | | | | | | | | | | | | | | | | | | | | | | | | | | | | | | | | | | | | | |
| <input type="checkbox"/> | 2 | 1 | <input type="checkbox"/> | | | | | | | | | | | | | | | | | | | | | | | | | | | | | | | | | | | | | | | | | | | | | | | | | | | | | | | | | | | | | | | | | | | | | | | | | | | | | | | | | | | | | | | | | | | | | | | | | | | | | | | | | | | | | | | | | | | | | | | | | | | | | | | | | | | | | | | | | | | | | | | | | | | | | | | | | | | | | | | | | | | | | | | | | | | | | | | | | | | | | | | | | | | | | | | | | | | | | | | | | | | | | | | | | | | | | | | | | | | | | | | | | | | | | | | | | | | | | | | | | | | | | | | | |
| <input type="checkbox"/> | 1 | 1 | <input type="checkbox"/> | | | | | | | | | | | | | | | | | | | | | | | | | | | | | | | | | | | | | | | | | | | | | | | | | | | | | | | | | | | | | | | | | | | | | | | | | | | | | | | | | | | | | | | | | | | | | | | | | | | | | | | | | | | | | | | | | | | | | | | | | | | | | | | | | | | | | | | | | | | | | | | | | | | | | | | | | | | | | | | | | | | | | | | | | | | | | | | | | | | | | | | | | | | | | | | | | | | | | | | | | | | | | | | | | | | | | | | | | | | | | | | | | | | | | | | | | | | | | | | | | | | | | | | | |
| <input type="checkbox"/> | - | - | <input type="checkbox"/> | | | | | | | | | | | | | | | | | | | | | | | | | | | | | | | | | | | | | | | | | | | | | | | | | | | | | | | | | | | | | | | | | | | | | | | | | | | | | | | | | | | | | | | | | | | | | | | | | | | | | | | | | | | | | | | | | | | | | | | | | | | | | | | | | | | | | | | | | | | | | | | | | | | | | | | | | | | | | | | | | | | | | | | | | | | | | | | | | | | | | | | | | | | | | | | | | | | | | | | | | | | | | | | | | | | | | | | | | | | | | | | | | | | | | | | | | | | | | | | | | | | | | | | | |
| <input type="checkbox"/> | - | - | <input type="checkbox"/> | | | | | | | | | | | | | | | | | | | | | | | | | | | | | | | | | | | | | | | | | | | | | | | | | | | | | | | | | | | | | | | | | | | | | | | | | | | | | | | | | | | | | | | | | | | | | | | | | | | | | | | | | | | | | | | | | | | | | | | | | | | | | | | | | | | | | | | | | | | | | | | | | | | | | | | | | | | | | | | | | | | | | | | | | | | | | | | | | | | | | | | | | | | | | | | | | | | | | | | | | | | | | | | | | | | | | | | | | | | | | | | | | | | | | | | | | | | | | | | | | | | | | | | | |
| <input type="checkbox"/> | - | - | <input type="checkbox"/> | | | | | | | | | | | | | | | | | | | | | | | | | | | | | | | | | | | | | | | | | | | | | | | | | | | | | | | | | | | | | | | | | | | | | | | | | | | | | | | | | | | | | | | | | | | | | | | | | | | | | | | | | | | | | | | | | | | | | | | | | | | | | | | | | | | | | | | | | | | | | | | | | | | | | | | | | | | | | | | | | | | | | | | | | | | | | | | | | | | | | | | | | | | | | | | | | | | | | | | | | | | | | | | | | | | | | | | | | | | | | | | | | | | | | | | | | | | | | | | | | | | | | | | | |
| <input type="checkbox"/> | - | - | <input type="checkbox"/> | | | | | | | | | | | | | | | | | | | | | | | | | | | | | | | | | | | | | | | | | | | | | | | | | | | | | | | | | | | | | | | | | | | | | | | | | | | | | | | | | | | | | | | | | | | | | | | | | | | | | | | | | | | | | | | | | | | | | | | | | | | | | | | | | | | | | | | | | | | | | | | | | | | | | | | | | | | | | | | | | | | | | | | | | | | | | | | | | | | | | | | | | | | | | | | | | | | | | | | | | | | | | | | | | | | | | | | | | | | | | | | | | | | | | | | | | | | | | | | | | | | | | | | | |
| <input type="checkbox"/> | - | - | <input type="checkbox"/> | | | | | | | | | | | | | | | | | | | | | | | | | | | | | | | | | | | | | | | | | | | | | | | | | | | | | | | | | | | | | | | | | | | | | | | | | | | | | | | | | | | | | | | | | | | | | | | | | | | | | | | | | | | | | | | | | | | | | | | | | | | | | | | | | | | | | | | | | | | | | | | | | | | | | | | | | | | | | | | | | | | | | | | | | | | | | | | | | | | | | | | | | | | | | | | | | | | | | | | | | | | | | | | | | | | | | | | | | | | | | | | | | | | | | | | | | | | | | | | | | | | | | | | | |
| <input type="checkbox"/> | - | - | <input type="checkbox"/> | | | | | | | | | | | | | | | | | | | | | | | | | | | | | | | | | | | | | | | | | | | | | | | | | | | | | | | | | | | | | | | | | | | | | | | | | | | | | | | | | | | | | | | | | | | | | | | | | | | | | | | | | | | | | | | | | | | | | | | | | | | | | | | | | | | | | | | | | | | | | | | | | | | | | | | | | | | | | | | | | | | | | | | | | | | | | | | | | | | | | | | | | | | | | | | | | | | | | | | | | | | | | | | | | | | | | | | | | | | | | | | | | | | | | | | | | | | | | | | | | | | | | | | | |
| <input type="checkbox"/> | - | - | <input type="checkbox"/> | | | | | | | | | | | | | | | | | | | | | | | | | | | | | | | | | | | | | | | | | | | | | | | | | | | | | | | | | | | | | | | | | | | | | | | | | | | | | | | | | | | | | | | | | | | | | | | | | | | | | | | | | | | | | | | | | | | | | | | | | | | | | | | | | | | | | | | | | | | | | | | | | | | | | | | | | | | | | | | | | | | | | | | | | | | | | | | | | | | | | | | | | | | | | | | | | | | | | | | | | | | | | | | | | | | | | | | | | | | | | | | | | | | | | | | | | | | | | | | | | | | | | | | | |
| <p>Two-choice answers, 20 questions, 60 points</p> <p style="text-align: center;">Code: 7014</p> <table style="width: 100%; border-collapse: collapse;"> <thead> <tr> <th style="text-align: left;">LEFT SIDE LIGHTS</th> <th style="text-align: center;">1</th> <th style="text-align: center;">1</th> <th style="text-align: right;">RIGHT SIDE LIGHTS</th> </tr> </thead> <tbody> <tr><td><input type="checkbox"/></td><td>1</td><td>1</td><td><input type="checkbox"/></td></tr> <tr><td><input type="checkbox"/></td><td>1</td><td>2</td><td><input type="checkbox"/></td></tr> <tr><td><input type="checkbox"/></td><td>1</td><td>1</td><td><input type="checkbox"/></td></tr> <tr><td><input type="checkbox"/></td><td>2</td><td>1</td><td><input type="checkbox"/></td></tr> <tr><td><input type="checkbox"/></td><td>1</td><td>1</td><td><input type="checkbox"/></td></tr> <tr><td><input type="checkbox"/></td><td>1</td><td>2</td><td><input type="checkbox"/></td></tr> <tr><td><input type="checkbox"/></td><td>1</td><td>2</td><td><input type="checkbox"/></td></tr> <tr><td><input type="checkbox"/></td><td>2</td><td>2</td><td><input type="checkbox"/></td></tr> <tr><td><input type="checkbox"/></td><td>2</td><td>2</td><td><input type="checkbox"/></td></tr> <tr><td><input type="checkbox"/></td><td>2</td><td>2</td><td><input type="checkbox"/></td></tr> <tr><td><input type="checkbox"/></td><td>-</td><td>-</td><td><input type="checkbox"/></td></tr> <tr><td><input type="checkbox"/></td><td>-</td><td>-</td><td><input type="checkbox"/></td></tr> <tr><td><input type="checkbox"/></td><td>-</td><td>-</td><td><input type="checkbox"/></td></tr> <tr><td><input type="checkbox"/></td><td>-</td><td>-</td><td><input type="checkbox"/></td></tr> </tbody> </table> | LEFT SIDE LIGHTS | 1 | 1 | RIGHT SIDE LIGHTS | <input type="checkbox"/> | 1 | 1 | <input type="checkbox"/> | <input type="checkbox"/> | 1 | 2 | <input type="checkbox"/> | <input type="checkbox"/> | 1 | 1 | <input type="checkbox"/> | <input type="checkbox"/> | 2 | 1 | <input type="checkbox"/> | <input type="checkbox"/> | 1 | 1 | <input type="checkbox"/> | <input type="checkbox"/> | 1 | 2 | <input type="checkbox"/> | <input type="checkbox"/> | 1 | 2 | <input type="checkbox"/> | <input type="checkbox"/> | 2 | 2 | <input type="checkbox"/> | <input type="checkbox"/> | 2 | 2 | <input type="checkbox"/> | <input type="checkbox"/> | 2 | 2 | <input type="checkbox"/> | <input type="checkbox"/> | - | - | <input type="checkbox"/> | <input type="checkbox"/> | - | - | <input type="checkbox"/> | <input type="checkbox"/> | - | - | <input type="checkbox"/> | <input type="checkbox"/> | - | - | <input type="checkbox"/> | <p>Two-choice answers, 20 questions, 60 points</p> <p style="text-align: center;">Code: 7060</p> <table style="width: 100%; border-collapse: collapse;"> <thead> <tr> <th style="text-align: left;">LEFT SIDE LIGHTS</th> <th style="text-align: center;">2</th> <th style="text-align: center;">1</th> <th style="text-align: right;">RIGHT SIDE LIGHTS</th> </tr> </thead> <tbody> <tr><td><input type="checkbox"/></td><td>2</td><td>1</td><td><input type="checkbox"/></td></tr> <tr><td><input type="checkbox"/></td><td>1</td><td>1</td><td><input type="checkbox"/></td></tr> <tr><td><input type="checkbox"/></td><td>1</td><td>2</td><td><input type="checkbox"/></td></tr> <tr><td><input type="checkbox"/></td><td>1</td><td>2</td><td><input type="checkbox"/></td></tr> <tr><td><input type="checkbox"/></td><td>1</td><td>2</td><td><input type="checkbox"/></td></tr> <tr><td><input type="checkbox"/></td><td>2</td><td>2</td><td><input type="checkbox"/></td></tr> <tr><td><input type="checkbox"/></td><td>1</td><td>2</td><td><input type="checkbox"/></td></tr> <tr><td><input type="checkbox"/></td><td>2</td><td>2</td><td><input type="checkbox"/></td></tr> <tr><td><input type="checkbox"/></td><td>1</td><td>1</td><td><input type="checkbox"/></td></tr> <tr><td><input type="checkbox"/></td><td>1</td><td>1</td><td><input type="checkbox"/></td></tr> <tr><td><input type="checkbox"/></td><td>-</td><td>-</td><td><input type="checkbox"/></td></tr> <tr><td><input type="checkbox"/></td><td>-</td><td>-</td><td><input type="checkbox"/></td></tr> <tr><td><input type="checkbox"/></td><td>-</td><td>-</td><td><input type="checkbox"/></td></tr> <tr><td><input type="checkbox"/></td><td>-</td><td>-</td><td><input type="checkbox"/></td></tr> </tbody> </table> | LEFT SIDE LIGHTS | 2 | 1 | RIGHT SIDE LIGHTS | <input type="checkbox"/> | 2 | 1 | <input type="checkbox"/> | <input type="checkbox"/> | 1 | 1 | <input type="checkbox"/> | <input type="checkbox"/> | 1 | 2 | <input type="checkbox"/> | <input type="checkbox"/> | 1 | 2 | <input type="checkbox"/> | <input type="checkbox"/> | 1 | 2 | <input type="checkbox"/> | <input type="checkbox"/> | 2 | 2 | <input type="checkbox"/> | <input type="checkbox"/> | 1 | 2 | <input type="checkbox"/> | <input type="checkbox"/> | 2 | 2 | <input type="checkbox"/> | <input type="checkbox"/> | 1 | 1 | <input type="checkbox"/> | <input type="checkbox"/> | 1 | 1 | <input type="checkbox"/> | <input type="checkbox"/> | - | - | <input type="checkbox"/> | <input type="checkbox"/> | - | - | <input type="checkbox"/> | <input type="checkbox"/> | - | - | <input type="checkbox"/> | <input type="checkbox"/> | - | - | <input type="checkbox"/> | <p>26 questions, 78 points</p> <p style="text-align: center;">Code: 8506</p> <table style="width: 100%; border-collapse: collapse;"> <thead> <tr> <th style="text-align: left;">LEFT SIDE LIGHTS</th> <th style="text-align: center;">2</th> <th style="text-align: center;">1</th> <th style="text-align: right;">RIGHT SIDE LIGHTS</th> </tr> </thead> <tbody> <tr><td><input type="checkbox"/></td><td>2</td><td>1</td><td><input type="checkbox"/></td></tr> <tr><td><input type="checkbox"/></td><td>2</td><td>2</td><td><input type="checkbox"/></td></tr> <tr><td><input type="checkbox"/></td><td>2</td><td>1</td><td><input type="checkbox"/></td></tr> <tr><td><input type="checkbox"/></td><td>1</td><td>2</td><td><input type="checkbox"/></td></tr> <tr><td><input type="checkbox"/></td><td>2</td><td>2</td><td><input type="checkbox"/></td></tr> <tr><td><input type="checkbox"/></td><td>1</td><td>1</td><td><input type="checkbox"/></td></tr> <tr><td><input type="checkbox"/></td><td>1</td><td>1</td><td><input type="checkbox"/></td></tr> <tr><td><input type="checkbox"/></td><td>1</td><td>1</td><td><input type="checkbox"/></td></tr> <tr><td><input type="checkbox"/></td><td>1</td><td>1</td><td><input type="checkbox"/></td></tr> <tr><td><input type="checkbox"/></td><td>1</td><td>2</td><td><input type="checkbox"/></td></tr> <tr><td><input type="checkbox"/></td><td>1</td><td>2</td><td><input type="checkbox"/></td></tr> <tr><td><input type="checkbox"/></td><td>1</td><td>2</td><td><input type="checkbox"/></td></tr> <tr><td><input type="checkbox"/></td><td>2</td><td>1</td><td><input type="checkbox"/></td></tr> <tr><td><input type="checkbox"/></td><td>2</td><td>1</td><td><input type="checkbox"/></td></tr> </tbody> </table> | LEFT SIDE LIGHTS | 2 | 1 | RIGHT SIDE LIGHTS | <input type="checkbox"/> | 2 | 1 | <input type="checkbox"/> | <input type="checkbox"/> | 2 | 2 | <input type="checkbox"/> | <input type="checkbox"/> | 2 | 1 | <input type="checkbox"/> | <input type="checkbox"/> | 1 | 2 | <input type="checkbox"/> | <input type="checkbox"/> | 2 | 2 | <input type="checkbox"/> | <input type="checkbox"/> | 1 | 1 | <input type="checkbox"/> | <input type="checkbox"/> | 1 | 1 | <input type="checkbox"/> | <input type="checkbox"/> | 1 | 1 | <input type="checkbox"/> | <input type="checkbox"/> | 1 | 1 | <input type="checkbox"/> | <input type="checkbox"/> | 1 | 2 | <input type="checkbox"/> | <input type="checkbox"/> | 1 | 2 | <input type="checkbox"/> | <input type="checkbox"/> | 1 | 2 | <input type="checkbox"/> | <input type="checkbox"/> | 2 | 1 | <input type="checkbox"/> | <input type="checkbox"/> | 2 | 1 | <input type="checkbox"/> | <p>Two-choice answers, 26 questions, 78 points</p> <p style="text-align: center;">Code: 8986</p> <table style="width: 100%; border-collapse: collapse;"> <thead> <tr> <th style="text-align: left;">LEFT SIDE LIGHTS</th> <th style="text-align: center;">1</th> <th style="text-align: center;">2</th> <th style="text-align: right;">RIGHT SIDE LIGHTS</th> </tr> </thead> <tbody> <tr><td><input type="checkbox"/></td><td>1</td><td>2</td><td><input type="checkbox"/></td></tr> <tr><td><input type="checkbox"/></td><td>2</td><td>2</td><td><input type="checkbox"/></td></tr> <tr><td><input type="checkbox"/></td><td>2</td><td>1</td><td><input type="checkbox"/></td></tr> <tr><td><input type="checkbox"/></td><td>1</td><td>2</td><td><input type="checkbox"/></td></tr> <tr><td><input type="checkbox"/></td><td>1</td><td>2</td><td><input type="checkbox"/></td></tr> <tr><td><input type="checkbox"/></td><td>2</td><td>1</td><td><input type="checkbox"/></td></tr> <tr><td><input type="checkbox"/></td><td>2</td><td>1</td><td><input type="checkbox"/></td></tr> <tr><td><input type="checkbox"/></td><td>2</td><td>2</td><td><input type="checkbox"/></td></tr> <tr><td><input type="checkbox"/></td><td>1</td><td>2</td><td><input type="checkbox"/></td></tr> <tr><td><input type="checkbox"/></td><td>1</td><td>1</td><td><input type="checkbox"/></td></tr> <tr><td><input type="checkbox"/></td><td>1</td><td>2</td><td><input type="checkbox"/></td></tr> <tr><td><input type="checkbox"/></td><td>1</td><td>1</td><td><input type="checkbox"/></td></tr> <tr><td><input type="checkbox"/></td><td>1</td><td>1</td><td><input type="checkbox"/></td></tr> <tr><td><input type="checkbox"/></td><td>2</td><td>2</td><td><input type="checkbox"/></td></tr> </tbody> </table> | LEFT SIDE LIGHTS | 1 | 2 | RIGHT SIDE LIGHTS | <input type="checkbox"/> | 1 | 2 | <input type="checkbox"/> | <input type="checkbox"/> | 2 | 2 | <input type="checkbox"/> | <input type="checkbox"/> | 2 | 1 | <input type="checkbox"/> | <input type="checkbox"/> | 1 | 2 | <input type="checkbox"/> | <input type="checkbox"/> | 1 | 2 | <input type="checkbox"/> | <input type="checkbox"/> | 2 | 1 | <input type="checkbox"/> | <input type="checkbox"/> | 2 | 1 | <input type="checkbox"/> | <input type="checkbox"/> | 2 | 2 | <input type="checkbox"/> | <input type="checkbox"/> | 1 | 2 | <input type="checkbox"/> | <input type="checkbox"/> | 1 | 1 | <input type="checkbox"/> | <input type="checkbox"/> | 1 | 2 | <input type="checkbox"/> | <input type="checkbox"/> | 1 | 1 | <input type="checkbox"/> | <input type="checkbox"/> | 1 | 1 | <input type="checkbox"/> | <input type="checkbox"/> | 2 | 2 | <input type="checkbox"/> | | | | | | | | |
| LEFT SIDE LIGHTS | 1 | 1 | RIGHT SIDE LIGHTS | | | | | | | | | | | | | | | | | | | | | | | | | | | | | | | | | | | | | | | | | | | | | | | | | | | | | | | | | | | | | | | | | | | | | | | | | | | | | | | | | | | | | | | | | | | | | | | | | | | | | | | | | | | | | | | | | | | | | | | | | | | | | | | | | | | | | | | | | | | | | | | | | | | | | | | | | | | | | | | | | | | | | | | | | | | | | | | | | | | | | | | | | | | | | | | | | | | | | | | | | | | | | | | | | | | | | | | | | | | | | | | | | | | | | | | | | | | | | | | | | | | | | | | | |
| <input type="checkbox"/> | 1 | 1 | <input type="checkbox"/> | | | | | | | | | | | | | | | | | | | | | | | | | | | | | | | | | | | | | | | | | | | | | | | | | | | | | | | | | | | | | | | | | | | | | | | | | | | | | | | | | | | | | | | | | | | | | | | | | | | | | | | | | | | | | | | | | | | | | | | | | | | | | | | | | | | | | | | | | | | | | | | | | | | | | | | | | | | | | | | | | | | | | | | | | | | | | | | | | | | | | | | | | | | | | | | | | | | | | | | | | | | | | | | | | | | | | | | | | | | | | | | | | | | | | | | | | | | | | | | | | | | | | | | | |
| <input type="checkbox"/> | 1 | 2 | <input type="checkbox"/> | | | | | | | | | | | | | | | | | | | | | | | | | | | | | | | | | | | | | | | | | | | | | | | | | | | | | | | | | | | | | | | | | | | | | | | | | | | | | | | | | | | | | | | | | | | | | | | | | | | | | | | | | | | | | | | | | | | | | | | | | | | | | | | | | | | | | | | | | | | | | | | | | | | | | | | | | | | | | | | | | | | | | | | | | | | | | | | | | | | | | | | | | | | | | | | | | | | | | | | | | | | | | | | | | | | | | | | | | | | | | | | | | | | | | | | | | | | | | | | | | | | | | | | | |
| <input type="checkbox"/> | 1 | 1 | <input type="checkbox"/> | | | | | | | | | | | | | | | | | | | | | | | | | | | | | | | | | | | | | | | | | | | | | | | | | | | | | | | | | | | | | | | | | | | | | | | | | | | | | | | | | | | | | | | | | | | | | | | | | | | | | | | | | | | | | | | | | | | | | | | | | | | | | | | | | | | | | | | | | | | | | | | | | | | | | | | | | | | | | | | | | | | | | | | | | | | | | | | | | | | | | | | | | | | | | | | | | | | | | | | | | | | | | | | | | | | | | | | | | | | | | | | | | | | | | | | | | | | | | | | | | | | | | | | | |
| <input type="checkbox"/> | 2 | 1 | <input type="checkbox"/> | | | | | | | | | | | | | | | | | | | | | | | | | | | | | | | | | | | | | | | | | | | | | | | | | | | | | | | | | | | | | | | | | | | | | | | | | | | | | | | | | | | | | | | | | | | | | | | | | | | | | | | | | | | | | | | | | | | | | | | | | | | | | | | | | | | | | | | | | | | | | | | | | | | | | | | | | | | | | | | | | | | | | | | | | | | | | | | | | | | | | | | | | | | | | | | | | | | | | | | | | | | | | | | | | | | | | | | | | | | | | | | | | | | | | | | | | | | | | | | | | | | | | | | | |
| <input type="checkbox"/> | 1 | 1 | <input type="checkbox"/> | | | | | | | | | | | | | | | | | | | | | | | | | | | | | | | | | | | | | | | | | | | | | | | | | | | | | | | | | | | | | | | | | | | | | | | | | | | | | | | | | | | | | | | | | | | | | | | | | | | | | | | | | | | | | | | | | | | | | | | | | | | | | | | | | | | | | | | | | | | | | | | | | | | | | | | | | | | | | | | | | | | | | | | | | | | | | | | | | | | | | | | | | | | | | | | | | | | | | | | | | | | | | | | | | | | | | | | | | | | | | | | | | | | | | | | | | | | | | | | | | | | | | | | | |
| <input type="checkbox"/> | 1 | 2 | <input type="checkbox"/> | | | | | | | | | | | | | | | | | | | | | | | | | | | | | | | | | | | | | | | | | | | | | | | | | | | | | | | | | | | | | | | | | | | | | | | | | | | | | | | | | | | | | | | | | | | | | | | | | | | | | | | | | | | | | | | | | | | | | | | | | | | | | | | | | | | | | | | | | | | | | | | | | | | | | | | | | | | | | | | | | | | | | | | | | | | | | | | | | | | | | | | | | | | | | | | | | | | | | | | | | | | | | | | | | | | | | | | | | | | | | | | | | | | | | | | | | | | | | | | | | | | | | | | | |
| <input type="checkbox"/> | 1 | 2 | <input type="checkbox"/> | | | | | | | | | | | | | | | | | | | | | | | | | | | | | | | | | | | | | | | | | | | | | | | | | | | | | | | | | | | | | | | | | | | | | | | | | | | | | | | | | | | | | | | | | | | | | | | | | | | | | | | | | | | | | | | | | | | | | | | | | | | | | | | | | | | | | | | | | | | | | | | | | | | | | | | | | | | | | | | | | | | | | | | | | | | | | | | | | | | | | | | | | | | | | | | | | | | | | | | | | | | | | | | | | | | | | | | | | | | | | | | | | | | | | | | | | | | | | | | | | | | | | | | | |
| <input type="checkbox"/> | 2 | 2 | <input type="checkbox"/> | | | | | | | | | | | | | | | | | | | | | | | | | | | | | | | | | | | | | | | | | | | | | | | | | | | | | | | | | | | | | | | | | | | | | | | | | | | | | | | | | | | | | | | | | | | | | | | | | | | | | | | | | | | | | | | | | | | | | | | | | | | | | | | | | | | | | | | | | | | | | | | | | | | | | | | | | | | | | | | | | | | | | | | | | | | | | | | | | | | | | | | | | | | | | | | | | | | | | | | | | | | | | | | | | | | | | | | | | | | | | | | | | | | | | | | | | | | | | | | | | | | | | | | | |
| <input type="checkbox"/> | 2 | 2 | <input type="checkbox"/> | | | | | | | | | | | | | | | | | | | | | | | | | | | | | | | | | | | | | | | | | | | | | | | | | | | | | | | | | | | | | | | | | | | | | | | | | | | | | | | | | | | | | | | | | | | | | | | | | | | | | | | | | | | | | | | | | | | | | | | | | | | | | | | | | | | | | | | | | | | | | | | | | | | | | | | | | | | | | | | | | | | | | | | | | | | | | | | | | | | | | | | | | | | | | | | | | | | | | | | | | | | | | | | | | | | | | | | | | | | | | | | | | | | | | | | | | | | | | | | | | | | | | | | | |
| <input type="checkbox"/> | 2 | 2 | <input type="checkbox"/> | | | | | | | | | | | | | | | | | | | | | | | | | | | | | | | | | | | | | | | | | | | | | | | | | | | | | | | | | | | | | | | | | | | | | | | | | | | | | | | | | | | | | | | | | | | | | | | | | | | | | | | | | | | | | | | | | | | | | | | | | | | | | | | | | | | | | | | | | | | | | | | | | | | | | | | | | | | | | | | | | | | | | | | | | | | | | | | | | | | | | | | | | | | | | | | | | | | | | | | | | | | | | | | | | | | | | | | | | | | | | | | | | | | | | | | | | | | | | | | | | | | | | | | | |
| <input type="checkbox"/> | - | - | <input type="checkbox"/> | | | | | | | | | | | | | | | | | | | | | | | | | | | | | | | | | | | | | | | | | | | | | | | | | | | | | | | | | | | | | | | | | | | | | | | | | | | | | | | | | | | | | | | | | | | | | | | | | | | | | | | | | | | | | | | | | | | | | | | | | | | | | | | | | | | | | | | | | | | | | | | | | | | | | | | | | | | | | | | | | | | | | | | | | | | | | | | | | | | | | | | | | | | | | | | | | | | | | | | | | | | | | | | | | | | | | | | | | | | | | | | | | | | | | | | | | | | | | | | | | | | | | | | | |
| <input type="checkbox"/> | - | - | <input type="checkbox"/> | | | | | | | | | | | | | | | | | | | | | | | | | | | | | | | | | | | | | | | | | | | | | | | | | | | | | | | | | | | | | | | | | | | | | | | | | | | | | | | | | | | | | | | | | | | | | | | | | | | | | | | | | | | | | | | | | | | | | | | | | | | | | | | | | | | | | | | | | | | | | | | | | | | | | | | | | | | | | | | | | | | | | | | | | | | | | | | | | | | | | | | | | | | | | | | | | | | | | | | | | | | | | | | | | | | | | | | | | | | | | | | | | | | | | | | | | | | | | | | | | | | | | | | | |
| <input type="checkbox"/> | - | - | <input type="checkbox"/> | | | | | | | | | | | | | | | | | | | | | | | | | | | | | | | | | | | | | | | | | | | | | | | | | | | | | | | | | | | | | | | | | | | | | | | | | | | | | | | | | | | | | | | | | | | | | | | | | | | | | | | | | | | | | | | | | | | | | | | | | | | | | | | | | | | | | | | | | | | | | | | | | | | | | | | | | | | | | | | | | | | | | | | | | | | | | | | | | | | | | | | | | | | | | | | | | | | | | | | | | | | | | | | | | | | | | | | | | | | | | | | | | | | | | | | | | | | | | | | | | | | | | | | | |
| <input type="checkbox"/> | - | - | <input type="checkbox"/> | | | | | | | | | | | | | | | | | | | | | | | | | | | | | | | | | | | | | | | | | | | | | | | | | | | | | | | | | | | | | | | | | | | | | | | | | | | | | | | | | | | | | | | | | | | | | | | | | | | | | | | | | | | | | | | | | | | | | | | | | | | | | | | | | | | | | | | | | | | | | | | | | | | | | | | | | | | | | | | | | | | | | | | | | | | | | | | | | | | | | | | | | | | | | | | | | | | | | | | | | | | | | | | | | | | | | | | | | | | | | | | | | | | | | | | | | | | | | | | | | | | | | | | | |
| LEFT SIDE LIGHTS | 2 | 1 | RIGHT SIDE LIGHTS | | | | | | | | | | | | | | | | | | | | | | | | | | | | | | | | | | | | | | | | | | | | | | | | | | | | | | | | | | | | | | | | | | | | | | | | | | | | | | | | | | | | | | | | | | | | | | | | | | | | | | | | | | | | | | | | | | | | | | | | | | | | | | | | | | | | | | | | | | | | | | | | | | | | | | | | | | | | | | | | | | | | | | | | | | | | | | | | | | | | | | | | | | | | | | | | | | | | | | | | | | | | | | | | | | | | | | | | | | | | | | | | | | | | | | | | | | | | | | | | | | | | | | | | |
| <input type="checkbox"/> | 2 | 1 | <input type="checkbox"/> | | | | | | | | | | | | | | | | | | | | | | | | | | | | | | | | | | | | | | | | | | | | | | | | | | | | | | | | | | | | | | | | | | | | | | | | | | | | | | | | | | | | | | | | | | | | | | | | | | | | | | | | | | | | | | | | | | | | | | | | | | | | | | | | | | | | | | | | | | | | | | | | | | | | | | | | | | | | | | | | | | | | | | | | | | | | | | | | | | | | | | | | | | | | | | | | | | | | | | | | | | | | | | | | | | | | | | | | | | | | | | | | | | | | | | | | | | | | | | | | | | | | | | | | |
| <input type="checkbox"/> | 1 | 1 | <input type="checkbox"/> | | | | | | | | | | | | | | | | | | | | | | | | | | | | | | | | | | | | | | | | | | | | | | | | | | | | | | | | | | | | | | | | | | | | | | | | | | | | | | | | | | | | | | | | | | | | | | | | | | | | | | | | | | | | | | | | | | | | | | | | | | | | | | | | | | | | | | | | | | | | | | | | | | | | | | | | | | | | | | | | | | | | | | | | | | | | | | | | | | | | | | | | | | | | | | | | | | | | | | | | | | | | | | | | | | | | | | | | | | | | | | | | | | | | | | | | | | | | | | | | | | | | | | | | |
| <input type="checkbox"/> | 1 | 2 | <input type="checkbox"/> | | | | | | | | | | | | | | | | | | | | | | | | | | | | | | | | | | | | | | | | | | | | | | | | | | | | | | | | | | | | | | | | | | | | | | | | | | | | | | | | | | | | | | | | | | | | | | | | | | | | | | | | | | | | | | | | | | | | | | | | | | | | | | | | | | | | | | | | | | | | | | | | | | | | | | | | | | | | | | | | | | | | | | | | | | | | | | | | | | | | | | | | | | | | | | | | | | | | | | | | | | | | | | | | | | | | | | | | | | | | | | | | | | | | | | | | | | | | | | | | | | | | | | | | |
| <input type="checkbox"/> | 1 | 2 | <input type="checkbox"/> | | | | | | | | | | | | | | | | | | | | | | | | | | | | | | | | | | | | | | | | | | | | | | | | | | | | | | | | | | | | | | | | | | | | | | | | | | | | | | | | | | | | | | | | | | | | | | | | | | | | | | | | | | | | | | | | | | | | | | | | | | | | | | | | | | | | | | | | | | | | | | | | | | | | | | | | | | | | | | | | | | | | | | | | | | | | | | | | | | | | | | | | | | | | | | | | | | | | | | | | | | | | | | | | | | | | | | | | | | | | | | | | | | | | | | | | | | | | | | | | | | | | | | | | |
| <input type="checkbox"/> | 1 | 2 | <input type="checkbox"/> | | | | | | | | | | | | | | | | | | | | | | | | | | | | | | | | | | | | | | | | | | | | | | | | | | | | | | | | | | | | | | | | | | | | | | | | | | | | | | | | | | | | | | | | | | | | | | | | | | | | | | | | | | | | | | | | | | | | | | | | | | | | | | | | | | | | | | | | | | | | | | | | | | | | | | | | | | | | | | | | | | | | | | | | | | | | | | | | | | | | | | | | | | | | | | | | | | | | | | | | | | | | | | | | | | | | | | | | | | | | | | | | | | | | | | | | | | | | | | | | | | | | | | | | |
| <input type="checkbox"/> | 2 | 2 | <input type="checkbox"/> | | | | | | | | | | | | | | | | | | | | | | | | | | | | | | | | | | | | | | | | | | | | | | | | | | | | | | | | | | | | | | | | | | | | | | | | | | | | | | | | | | | | | | | | | | | | | | | | | | | | | | | | | | | | | | | | | | | | | | | | | | | | | | | | | | | | | | | | | | | | | | | | | | | | | | | | | | | | | | | | | | | | | | | | | | | | | | | | | | | | | | | | | | | | | | | | | | | | | | | | | | | | | | | | | | | | | | | | | | | | | | | | | | | | | | | | | | | | | | | | | | | | | | | | |
| <input type="checkbox"/> | 1 | 2 | <input type="checkbox"/> | | | | | | | | | | | | | | | | | | | | | | | | | | | | | | | | | | | | | | | | | | | | | | | | | | | | | | | | | | | | | | | | | | | | | | | | | | | | | | | | | | | | | | | | | | | | | | | | | | | | | | | | | | | | | | | | | | | | | | | | | | | | | | | | | | | | | | | | | | | | | | | | | | | | | | | | | | | | | | | | | | | | | | | | | | | | | | | | | | | | | | | | | | | | | | | | | | | | | | | | | | | | | | | | | | | | | | | | | | | | | | | | | | | | | | | | | | | | | | | | | | | | | | | | |
| <input type="checkbox"/> | 2 | 2 | <input type="checkbox"/> | | | | | | | | | | | | | | | | | | | | | | | | | | | | | | | | | | | | | | | | | | | | | | | | | | | | | | | | | | | | | | | | | | | | | | | | | | | | | | | | | | | | | | | | | | | | | | | | | | | | | | | | | | | | | | | | | | | | | | | | | | | | | | | | | | | | | | | | | | | | | | | | | | | | | | | | | | | | | | | | | | | | | | | | | | | | | | | | | | | | | | | | | | | | | | | | | | | | | | | | | | | | | | | | | | | | | | | | | | | | | | | | | | | | | | | | | | | | | | | | | | | | | | | | |
| <input type="checkbox"/> | 1 | 1 | <input type="checkbox"/> | | | | | | | | | | | | | | | | | | | | | | | | | | | | | | | | | | | | | | | | | | | | | | | | | | | | | | | | | | | | | | | | | | | | | | | | | | | | | | | | | | | | | | | | | | | | | | | | | | | | | | | | | | | | | | | | | | | | | | | | | | | | | | | | | | | | | | | | | | | | | | | | | | | | | | | | | | | | | | | | | | | | | | | | | | | | | | | | | | | | | | | | | | | | | | | | | | | | | | | | | | | | | | | | | | | | | | | | | | | | | | | | | | | | | | | | | | | | | | | | | | | | | | | | |
| <input type="checkbox"/> | 1 | 1 | <input type="checkbox"/> | | | | | | | | | | | | | | | | | | | | | | | | | | | | | | | | | | | | | | | | | | | | | | | | | | | | | | | | | | | | | | | | | | | | | | | | | | | | | | | | | | | | | | | | | | | | | | | | | | | | | | | | | | | | | | | | | | | | | | | | | | | | | | | | | | | | | | | | | | | | | | | | | | | | | | | | | | | | | | | | | | | | | | | | | | | | | | | | | | | | | | | | | | | | | | | | | | | | | | | | | | | | | | | | | | | | | | | | | | | | | | | | | | | | | | | | | | | | | | | | | | | | | | | | |
| <input type="checkbox"/> | - | - | <input type="checkbox"/> | | | | | | | | | | | | | | | | | | | | | | | | | | | | | | | | | | | | | | | | | | | | | | | | | | | | | | | | | | | | | | | | | | | | | | | | | | | | | | | | | | | | | | | | | | | | | | | | | | | | | | | | | | | | | | | | | | | | | | | | | | | | | | | | | | | | | | | | | | | | | | | | | | | | | | | | | | | | | | | | | | | | | | | | | | | | | | | | | | | | | | | | | | | | | | | | | | | | | | | | | | | | | | | | | | | | | | | | | | | | | | | | | | | | | | | | | | | | | | | | | | | | | | | | |
| <input type="checkbox"/> | - | - | <input type="checkbox"/> | | | | | | | | | | | | | | | | | | | | | | | | | | | | | | | | | | | | | | | | | | | | | | | | | | | | | | | | | | | | | | | | | | | | | | | | | | | | | | | | | | | | | | | | | | | | | | | | | | | | | | | | | | | | | | | | | | | | | | | | | | | | | | | | | | | | | | | | | | | | | | | | | | | | | | | | | | | | | | | | | | | | | | | | | | | | | | | | | | | | | | | | | | | | | | | | | | | | | | | | | | | | | | | | | | | | | | | | | | | | | | | | | | | | | | | | | | | | | | | | | | | | | | | | |
| <input type="checkbox"/> | - | - | <input type="checkbox"/> | | | | | | | | | | | | | | | | | | | | | | | | | | | | | | | | | | | | | | | | | | | | | | | | | | | | | | | | | | | | | | | | | | | | | | | | | | | | | | | | | | | | | | | | | | | | | | | | | | | | | | | | | | | | | | | | | | | | | | | | | | | | | | | | | | | | | | | | | | | | | | | | | | | | | | | | | | | | | | | | | | | | | | | | | | | | | | | | | | | | | | | | | | | | | | | | | | | | | | | | | | | | | | | | | | | | | | | | | | | | | | | | | | | | | | | | | | | | | | | | | | | | | | | | |
| <input type="checkbox"/> | - | - | <input type="checkbox"/> | | | | | | | | | | | | | | | | | | | | | | | | | | | | | | | | | | | | | | | | | | | | | | | | | | | | | | | | | | | | | | | | | | | | | | | | | | | | | | | | | | | | | | | | | | | | | | | | | | | | | | | | | | | | | | | | | | | | | | | | | | | | | | | | | | | | | | | | | | | | | | | | | | | | | | | | | | | | | | | | | | | | | | | | | | | | | | | | | | | | | | | | | | | | | | | | | | | | | | | | | | | | | | | | | | | | | | | | | | | | | | | | | | | | | | | | | | | | | | | | | | | | | | | | |
| LEFT SIDE LIGHTS | 2 | 1 | RIGHT SIDE LIGHTS | | | | | | | | | | | | | | | | | | | | | | | | | | | | | | | | | | | | | | | | | | | | | | | | | | | | | | | | | | | | | | | | | | | | | | | | | | | | | | | | | | | | | | | | | | | | | | | | | | | | | | | | | | | | | | | | | | | | | | | | | | | | | | | | | | | | | | | | | | | | | | | | | | | | | | | | | | | | | | | | | | | | | | | | | | | | | | | | | | | | | | | | | | | | | | | | | | | | | | | | | | | | | | | | | | | | | | | | | | | | | | | | | | | | | | | | | | | | | | | | | | | | | | | | |
| <input type="checkbox"/> | 2 | 1 | <input type="checkbox"/> | | | | | | | | | | | | | | | | | | | | | | | | | | | | | | | | | | | | | | | | | | | | | | | | | | | | | | | | | | | | | | | | | | | | | | | | | | | | | | | | | | | | | | | | | | | | | | | | | | | | | | | | | | | | | | | | | | | | | | | | | | | | | | | | | | | | | | | | | | | | | | | | | | | | | | | | | | | | | | | | | | | | | | | | | | | | | | | | | | | | | | | | | | | | | | | | | | | | | | | | | | | | | | | | | | | | | | | | | | | | | | | | | | | | | | | | | | | | | | | | | | | | | | | | |
| <input type="checkbox"/> | 2 | 2 | <input type="checkbox"/> | | | | | | | | | | | | | | | | | | | | | | | | | | | | | | | | | | | | | | | | | | | | | | | | | | | | | | | | | | | | | | | | | | | | | | | | | | | | | | | | | | | | | | | | | | | | | | | | | | | | | | | | | | | | | | | | | | | | | | | | | | | | | | | | | | | | | | | | | | | | | | | | | | | | | | | | | | | | | | | | | | | | | | | | | | | | | | | | | | | | | | | | | | | | | | | | | | | | | | | | | | | | | | | | | | | | | | | | | | | | | | | | | | | | | | | | | | | | | | | | | | | | | | | | |
| <input type="checkbox"/> | 2 | 1 | <input type="checkbox"/> | | | | | | | | | | | | | | | | | | | | | | | | | | | | | | | | | | | | | | | | | | | | | | | | | | | | | | | | | | | | | | | | | | | | | | | | | | | | | | | | | | | | | | | | | | | | | | | | | | | | | | | | | | | | | | | | | | | | | | | | | | | | | | | | | | | | | | | | | | | | | | | | | | | | | | | | | | | | | | | | | | | | | | | | | | | | | | | | | | | | | | | | | | | | | | | | | | | | | | | | | | | | | | | | | | | | | | | | | | | | | | | | | | | | | | | | | | | | | | | | | | | | | | | | |
| <input type="checkbox"/> | 1 | 2 | <input type="checkbox"/> | | | | | | | | | | | | | | | | | | | | | | | | | | | | | | | | | | | | | | | | | | | | | | | | | | | | | | | | | | | | | | | | | | | | | | | | | | | | | | | | | | | | | | | | | | | | | | | | | | | | | | | | | | | | | | | | | | | | | | | | | | | | | | | | | | | | | | | | | | | | | | | | | | | | | | | | | | | | | | | | | | | | | | | | | | | | | | | | | | | | | | | | | | | | | | | | | | | | | | | | | | | | | | | | | | | | | | | | | | | | | | | | | | | | | | | | | | | | | | | | | | | | | | | | |
| <input type="checkbox"/> | 2 | 2 | <input type="checkbox"/> | | | | | | | | | | | | | | | | | | | | | | | | | | | | | | | | | | | | | | | | | | | | | | | | | | | | | | | | | | | | | | | | | | | | | | | | | | | | | | | | | | | | | | | | | | | | | | | | | | | | | | | | | | | | | | | | | | | | | | | | | | | | | | | | | | | | | | | | | | | | | | | | | | | | | | | | | | | | | | | | | | | | | | | | | | | | | | | | | | | | | | | | | | | | | | | | | | | | | | | | | | | | | | | | | | | | | | | | | | | | | | | | | | | | | | | | | | | | | | | | | | | | | | | | |
| <input type="checkbox"/> | 1 | 1 | <input type="checkbox"/> | | | | | | | | | | | | | | | | | | | | | | | | | | | | | | | | | | | | | | | | | | | | | | | | | | | | | | | | | | | | | | | | | | | | | | | | | | | | | | | | | | | | | | | | | | | | | | | | | | | | | | | | | | | | | | | | | | | | | | | | | | | | | | | | | | | | | | | | | | | | | | | | | | | | | | | | | | | | | | | | | | | | | | | | | | | | | | | | | | | | | | | | | | | | | | | | | | | | | | | | | | | | | | | | | | | | | | | | | | | | | | | | | | | | | | | | | | | | | | | | | | | | | | | | |
| <input type="checkbox"/> | 1 | 1 | <input type="checkbox"/> | | | | | | | | | | | | | | | | | | | | | | | | | | | | | | | | | | | | | | | | | | | | | | | | | | | | | | | | | | | | | | | | | | | | | | | | | | | | | | | | | | | | | | | | | | | | | | | | | | | | | | | | | | | | | | | | | | | | | | | | | | | | | | | | | | | | | | | | | | | | | | | | | | | | | | | | | | | | | | | | | | | | | | | | | | | | | | | | | | | | | | | | | | | | | | | | | | | | | | | | | | | | | | | | | | | | | | | | | | | | | | | | | | | | | | | | | | | | | | | | | | | | | | | | |
| <input type="checkbox"/> | 1 | 1 | <input type="checkbox"/> | | | | | | | | | | | | | | | | | | | | | | | | | | | | | | | | | | | | | | | | | | | | | | | | | | | | | | | | | | | | | | | | | | | | | | | | | | | | | | | | | | | | | | | | | | | | | | | | | | | | | | | | | | | | | | | | | | | | | | | | | | | | | | | | | | | | | | | | | | | | | | | | | | | | | | | | | | | | | | | | | | | | | | | | | | | | | | | | | | | | | | | | | | | | | | | | | | | | | | | | | | | | | | | | | | | | | | | | | | | | | | | | | | | | | | | | | | | | | | | | | | | | | | | | |
| <input type="checkbox"/> | 1 | 1 | <input type="checkbox"/> | | | | | | | | | | | | | | | | | | | | | | | | | | | | | | | | | | | | | | | | | | | | | | | | | | | | | | | | | | | | | | | | | | | | | | | | | | | | | | | | | | | | | | | | | | | | | | | | | | | | | | | | | | | | | | | | | | | | | | | | | | | | | | | | | | | | | | | | | | | | | | | | | | | | | | | | | | | | | | | | | | | | | | | | | | | | | | | | | | | | | | | | | | | | | | | | | | | | | | | | | | | | | | | | | | | | | | | | | | | | | | | | | | | | | | | | | | | | | | | | | | | | | | | | |
| <input type="checkbox"/> | 1 | 2 | <input type="checkbox"/> | | | | | | | | | | | | | | | | | | | | | | | | | | | | | | | | | | | | | | | | | | | | | | | | | | | | | | | | | | | | | | | | | | | | | | | | | | | | | | | | | | | | | | | | | | | | | | | | | | | | | | | | | | | | | | | | | | | | | | | | | | | | | | | | | | | | | | | | | | | | | | | | | | | | | | | | | | | | | | | | | | | | | | | | | | | | | | | | | | | | | | | | | | | | | | | | | | | | | | | | | | | | | | | | | | | | | | | | | | | | | | | | | | | | | | | | | | | | | | | | | | | | | | | | |
| <input type="checkbox"/> | 1 | 2 | <input type="checkbox"/> | | | | | | | | | | | | | | | | | | | | | | | | | | | | | | | | | | | | | | | | | | | | | | | | | | | | | | | | | | | | | | | | | | | | | | | | | | | | | | | | | | | | | | | | | | | | | | | | | | | | | | | | | | | | | | | | | | | | | | | | | | | | | | | | | | | | | | | | | | | | | | | | | | | | | | | | | | | | | | | | | | | | | | | | | | | | | | | | | | | | | | | | | | | | | | | | | | | | | | | | | | | | | | | | | | | | | | | | | | | | | | | | | | | | | | | | | | | | | | | | | | | | | | | | |
| <input type="checkbox"/> | 1 | 2 | <input type="checkbox"/> | | | | | | | | | | | | | | | | | | | | | | | | | | | | | | | | | | | | | | | | | | | | | | | | | | | | | | | | | | | | | | | | | | | | | | | | | | | | | | | | | | | | | | | | | | | | | | | | | | | | | | | | | | | | | | | | | | | | | | | | | | | | | | | | | | | | | | | | | | | | | | | | | | | | | | | | | | | | | | | | | | | | | | | | | | | | | | | | | | | | | | | | | | | | | | | | | | | | | | | | | | | | | | | | | | | | | | | | | | | | | | | | | | | | | | | | | | | | | | | | | | | | | | | | |
| <input type="checkbox"/> | 2 | 1 | <input type="checkbox"/> | | | | | | | | | | | | | | | | | | | | | | | | | | | | | | | | | | | | | | | | | | | | | | | | | | | | | | | | | | | | | | | | | | | | | | | | | | | | | | | | | | | | | | | | | | | | | | | | | | | | | | | | | | | | | | | | | | | | | | | | | | | | | | | | | | | | | | | | | | | | | | | | | | | | | | | | | | | | | | | | | | | | | | | | | | | | | | | | | | | | | | | | | | | | | | | | | | | | | | | | | | | | | | | | | | | | | | | | | | | | | | | | | | | | | | | | | | | | | | | | | | | | | | | | |
| <input type="checkbox"/> | 2 | 1 | <input type="checkbox"/> | | | | | | | | | | | | | | | | | | | | | | | | | | | | | | | | | | | | | | | | | | | | | | | | | | | | | | | | | | | | | | | | | | | | | | | | | | | | | | | | | | | | | | | | | | | | | | | | | | | | | | | | | | | | | | | | | | | | | | | | | | | | | | | | | | | | | | | | | | | | | | | | | | | | | | | | | | | | | | | | | | | | | | | | | | | | | | | | | | | | | | | | | | | | | | | | | | | | | | | | | | | | | | | | | | | | | | | | | | | | | | | | | | | | | | | | | | | | | | | | | | | | | | | | |
| LEFT SIDE LIGHTS | 1 | 2 | RIGHT SIDE LIGHTS | | | | | | | | | | | | | | | | | | | | | | | | | | | | | | | | | | | | | | | | | | | | | | | | | | | | | | | | | | | | | | | | | | | | | | | | | | | | | | | | | | | | | | | | | | | | | | | | | | | | | | | | | | | | | | | | | | | | | | | | | | | | | | | | | | | | | | | | | | | | | | | | | | | | | | | | | | | | | | | | | | | | | | | | | | | | | | | | | | | | | | | | | | | | | | | | | | | | | | | | | | | | | | | | | | | | | | | | | | | | | | | | | | | | | | | | | | | | | | | | | | | | | | | | |
| <input type="checkbox"/> | 1 | 2 | <input type="checkbox"/> | | | | | | | | | | | | | | | | | | | | | | | | | | | | | | | | | | | | | | | | | | | | | | | | | | | | | | | | | | | | | | | | | | | | | | | | | | | | | | | | | | | | | | | | | | | | | | | | | | | | | | | | | | | | | | | | | | | | | | | | | | | | | | | | | | | | | | | | | | | | | | | | | | | | | | | | | | | | | | | | | | | | | | | | | | | | | | | | | | | | | | | | | | | | | | | | | | | | | | | | | | | | | | | | | | | | | | | | | | | | | | | | | | | | | | | | | | | | | | | | | | | | | | | | |
| <input type="checkbox"/> | 2 | 2 | <input type="checkbox"/> | | | | | | | | | | | | | | | | | | | | | | | | | | | | | | | | | | | | | | | | | | | | | | | | | | | | | | | | | | | | | | | | | | | | | | | | | | | | | | | | | | | | | | | | | | | | | | | | | | | | | | | | | | | | | | | | | | | | | | | | | | | | | | | | | | | | | | | | | | | | | | | | | | | | | | | | | | | | | | | | | | | | | | | | | | | | | | | | | | | | | | | | | | | | | | | | | | | | | | | | | | | | | | | | | | | | | | | | | | | | | | | | | | | | | | | | | | | | | | | | | | | | | | | | |
| <input type="checkbox"/> | 2 | 1 | <input type="checkbox"/> | | | | | | | | | | | | | | | | | | | | | | | | | | | | | | | | | | | | | | | | | | | | | | | | | | | | | | | | | | | | | | | | | | | | | | | | | | | | | | | | | | | | | | | | | | | | | | | | | | | | | | | | | | | | | | | | | | | | | | | | | | | | | | | | | | | | | | | | | | | | | | | | | | | | | | | | | | | | | | | | | | | | | | | | | | | | | | | | | | | | | | | | | | | | | | | | | | | | | | | | | | | | | | | | | | | | | | | | | | | | | | | | | | | | | | | | | | | | | | | | | | | | | | | | |
| <input type="checkbox"/> | 1 | 2 | <input type="checkbox"/> | | | | | | | | | | | | | | | | | | | | | | | | | | | | | | | | | | | | | | | | | | | | | | | | | | | | | | | | | | | | | | | | | | | | | | | | | | | | | | | | | | | | | | | | | | | | | | | | | | | | | | | | | | | | | | | | | | | | | | | | | | | | | | | | | | | | | | | | | | | | | | | | | | | | | | | | | | | | | | | | | | | | | | | | | | | | | | | | | | | | | | | | | | | | | | | | | | | | | | | | | | | | | | | | | | | | | | | | | | | | | | | | | | | | | | | | | | | | | | | | | | | | | | | | |
| <input type="checkbox"/> | 1 | 2 | <input type="checkbox"/> | | | | | | | | | | | | | | | | | | | | | | | | | | | | | | | | | | | | | | | | | | | | | | | | | | | | | | | | | | | | | | | | | | | | | | | | | | | | | | | | | | | | | | | | | | | | | | | | | | | | | | | | | | | | | | | | | | | | | | | | | | | | | | | | | | | | | | | | | | | | | | | | | | | | | | | | | | | | | | | | | | | | | | | | | | | | | | | | | | | | | | | | | | | | | | | | | | | | | | | | | | | | | | | | | | | | | | | | | | | | | | | | | | | | | | | | | | | | | | | | | | | | | | | | |
| <input type="checkbox"/> | 2 | 1 | <input type="checkbox"/> | | | | | | | | | | | | | | | | | | | | | | | | | | | | | | | | | | | | | | | | | | | | | | | | | | | | | | | | | | | | | | | | | | | | | | | | | | | | | | | | | | | | | | | | | | | | | | | | | | | | | | | | | | | | | | | | | | | | | | | | | | | | | | | | | | | | | | | | | | | | | | | | | | | | | | | | | | | | | | | | | | | | | | | | | | | | | | | | | | | | | | | | | | | | | | | | | | | | | | | | | | | | | | | | | | | | | | | | | | | | | | | | | | | | | | | | | | | | | | | | | | | | | | | | |
| <input type="checkbox"/> | 2 | 1 | <input type="checkbox"/> | | | | | | | | | | | | | | | | | | | | | | | | | | | | | | | | | | | | | | | | | | | | | | | | | | | | | | | | | | | | | | | | | | | | | | | | | | | | | | | | | | | | | | | | | | | | | | | | | | | | | | | | | | | | | | | | | | | | | | | | | | | | | | | | | | | | | | | | | | | | | | | | | | | | | | | | | | | | | | | | | | | | | | | | | | | | | | | | | | | | | | | | | | | | | | | | | | | | | | | | | | | | | | | | | | | | | | | | | | | | | | | | | | | | | | | | | | | | | | | | | | | | | | | | |
| <input type="checkbox"/> | 2 | 2 | <input type="checkbox"/> | | | | | | | | | | | | | | | | | | | | | | | | | | | | | | | | | | | | | | | | | | | | | | | | | | | | | | | | | | | | | | | | | | | | | | | | | | | | | | | | | | | | | | | | | | | | | | | | | | | | | | | | | | | | | | | | | | | | | | | | | | | | | | | | | | | | | | | | | | | | | | | | | | | | | | | | | | | | | | | | | | | | | | | | | | | | | | | | | | | | | | | | | | | | | | | | | | | | | | | | | | | | | | | | | | | | | | | | | | | | | | | | | | | | | | | | | | | | | | | | | | | | | | | | |
| <input type="checkbox"/> | 1 | 2 | <input type="checkbox"/> | | | | | | | | | | | | | | | | | | | | | | | | | | | | | | | | | | | | | | | | | | | | | | | | | | | | | | | | | | | | | | | | | | | | | | | | | | | | | | | | | | | | | | | | | | | | | | | | | | | | | | | | | | | | | | | | | | | | | | | | | | | | | | | | | | | | | | | | | | | | | | | | | | | | | | | | | | | | | | | | | | | | | | | | | | | | | | | | | | | | | | | | | | | | | | | | | | | | | | | | | | | | | | | | | | | | | | | | | | | | | | | | | | | | | | | | | | | | | | | | | | | | | | | | |
| <input type="checkbox"/> | 1 | 1 | <input type="checkbox"/> | | | | | | | | | | | | | | | | | | | | | | | | | | | | | | | | | | | | | | | | | | | | | | | | | | | | | | | | | | | | | | | | | | | | | | | | | | | | | | | | | | | | | | | | | | | | | | | | | | | | | | | | | | | | | | | | | | | | | | | | | | | | | | | | | | | | | | | | | | | | | | | | | | | | | | | | | | | | | | | | | | | | | | | | | | | | | | | | | | | | | | | | | | | | | | | | | | | | | | | | | | | | | | | | | | | | | | | | | | | | | | | | | | | | | | | | | | | | | | | | | | | | | | | | |
| <input type="checkbox"/> | 1 | 2 | <input type="checkbox"/> | | | | | | | | | | | | | | | | | | | | | | | | | | | | | | | | | | | | | | | | | | | | | | | | | | | | | | | | | | | | | | | | | | | | | | | | | | | | | | | | | | | | | | | | | | | | | | | | | | | | | | | | | | | | | | | | | | | | | | | | | | | | | | | | | | | | | | | | | | | | | | | | | | | | | | | | | | | | | | | | | | | | | | | | | | | | | | | | | | | | | | | | | | | | | | | | | | | | | | | | | | | | | | | | | | | | | | | | | | | | | | | | | | | | | | | | | | | | | | | | | | | | | | | | |
| <input type="checkbox"/> | 1 | 1 | <input type="checkbox"/> | | | | | | | | | | | | | | | | | | | | | | | | | | | | | | | | | | | | | | | | | | | | | | | | | | | | | | | | | | | | | | | | | | | | | | | | | | | | | | | | | | | | | | | | | | | | | | | | | | | | | | | | | | | | | | | | | | | | | | | | | | | | | | | | | | | | | | | | | | | | | | | | | | | | | | | | | | | | | | | | | | | | | | | | | | | | | | | | | | | | | | | | | | | | | | | | | | | | | | | | | | | | | | | | | | | | | | | | | | | | | | | | | | | | | | | | | | | | | | | | | | | | | | | | |
| <input type="checkbox"/> | 1 | 1 | <input type="checkbox"/> | | | | | | | | | | | | | | | | | | | | | | | | | | | | | | | | | | | | | | | | | | | | | | | | | | | | | | | | | | | | | | | | | | | | | | | | | | | | | | | | | | | | | | | | | | | | | | | | | | | | | | | | | | | | | | | | | | | | | | | | | | | | | | | | | | | | | | | | | | | | | | | | | | | | | | | | | | | | | | | | | | | | | | | | | | | | | | | | | | | | | | | | | | | | | | | | | | | | | | | | | | | | | | | | | | | | | | | | | | | | | | | | | | | | | | | | | | | | | | | | | | | | | | | | |
| <input type="checkbox"/> | 2 | 2 | <input type="checkbox"/> | | | | | | | | | | | | | | | | | | | | | | | | | | | | | | | | | | | | | | | | | | | | | | | | | | | | | | | | | | | | | | | | | | | | | | | | | | | | | | | | | | | | | | | | | | | | | | | | | | | | | | | | | | | | | | | | | | | | | | | | | | | | | | | | | | | | | | | | | | | | | | | | | | | | | | | | | | | | | | | | | | | | | | | | | | | | | | | | | | | | | | | | | | | | | | | | | | | | | | | | | | | | | | | | | | | | | | | | | | | | | | | | | | | | | | | | | | | | | | | | | | | | | | | | |

USING FOUR-CHOICE ANSWER CODES

Four-choice codes are useful when you want answers to fall into one of four categories. Answers on these cards, regardless of how many questions you ask, will be number keys 1, 2, 3, or 4.

1. Decide the number of questions you want to ask. **GeoSafari's** built-in answer codes offer you a choice of 10, 12, 14, 16, 20, or 26 questions.

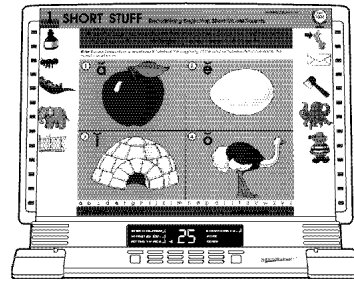

2. Divide your questions into two groups to place on the left and right sides of the card. Write each question beside the corresponding question light. The card shown here has 10 questions, divided into two groups of five. Notice that with this code, every other light on both the left and right sides has no question beside it. The last four lights on both sides are also blank.

3. With four-choice codes, answers in each category are not represented equally in each code. For instance, one code may have four questions for which the answer is 3. Another code may have only two questions for which the answer is 3. Pick a code, note the answer for each question, then select appropriate questions to fit that code.

4. The middle panel of a four-choice card might have a key identifying each of the four categories or choices. You may also divide the middle into four panels, each numbered 1, 2, 3, or 4 as a basis for answers. For an example, see the card shown here.

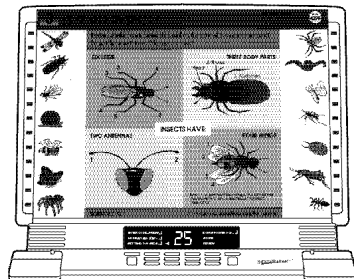

FOUR-CHOICE ANSWER CODES

The answers for each of the four-choice answer codes (shown on the next page) are arranged in a pattern similar to the layout of the **GeoSafari** machine. Each dash represents a position at which there is no question. Place the corresponding answer numbers on the correct part of the illustration in the middle panel.

Four-Choice Answer Codes

| <p>Four-choice answers, 10 questions, 30 points</p> <p style="text-align: center;">Code: 1501</p> <table style="width: 100%; border-collapse: collapse;"> <thead> <tr> <th style="text-align: left;">LEFT SIDE LIGHTS</th> <th style="text-align: center;">2</th> <th style="text-align: center;">1</th> <th style="text-align: right;">RIGHT SIDE LIGHTS</th> </tr> </thead> <tbody> <tr><td><input type="checkbox"/></td><td>2</td><td>1</td><td><input type="checkbox"/></td></tr> <tr><td><input type="checkbox"/></td><td>-</td><td>-</td><td><input type="checkbox"/></td></tr> <tr><td><input type="checkbox"/></td><td>4</td><td>4</td><td><input type="checkbox"/></td></tr> <tr><td><input type="checkbox"/></td><td>-</td><td>-</td><td><input type="checkbox"/></td></tr> <tr><td><input type="checkbox"/></td><td>3</td><td>1</td><td><input type="checkbox"/></td></tr> <tr><td><input type="checkbox"/></td><td>-</td><td>-</td><td><input type="checkbox"/></td></tr> <tr><td><input type="checkbox"/></td><td>2</td><td>4</td><td><input type="checkbox"/></td></tr> <tr><td><input type="checkbox"/></td><td>-</td><td>-</td><td><input type="checkbox"/></td></tr> <tr><td><input type="checkbox"/></td><td>3</td><td>1</td><td><input type="checkbox"/></td></tr> <tr><td><input type="checkbox"/></td><td>-</td><td>-</td><td><input type="checkbox"/></td></tr> <tr><td><input type="checkbox"/></td><td>-</td><td>-</td><td><input type="checkbox"/></td></tr> <tr><td><input type="checkbox"/></td><td>-</td><td>-</td><td><input type="checkbox"/></td></tr> <tr><td><input type="checkbox"/></td><td>-</td><td>-</td><td><input type="checkbox"/></td></tr> <tr><td><input type="checkbox"/></td><td>-</td><td>-</td><td><input type="checkbox"/></td></tr> </tbody> </table> | LEFT SIDE LIGHTS | 2 | 1 | RIGHT SIDE LIGHTS | <input type="checkbox"/> | 2 | 1 | <input type="checkbox"/> | <input type="checkbox"/> | - | - | <input type="checkbox"/> | <input type="checkbox"/> | 4 | 4 | <input type="checkbox"/> | <input type="checkbox"/> | - | - | <input type="checkbox"/> | <input type="checkbox"/> | 3 | 1 | <input type="checkbox"/> | <input type="checkbox"/> | - | - | <input type="checkbox"/> | <input type="checkbox"/> | 2 | 4 | <input type="checkbox"/> | <input type="checkbox"/> | - | - | <input type="checkbox"/> | <input type="checkbox"/> | 3 | 1 | <input type="checkbox"/> | <input type="checkbox"/> | - | - | <input type="checkbox"/> | <input type="checkbox"/> | - | - | <input type="checkbox"/> | <input type="checkbox"/> | - | - | <input type="checkbox"/> | <input type="checkbox"/> | - | - | <input type="checkbox"/> | <input type="checkbox"/> | - | - | <input type="checkbox"/> | <p>Four-choice answers, 10 questions, 30 points</p> <p style="text-align: center;">Code: 1980</p> <table style="width: 100%; border-collapse: collapse;"> <thead> <tr> <th style="text-align: left;">LEFT SIDE LIGHTS</th> <th style="text-align: center;">3</th> <th style="text-align: center;">4</th> <th style="text-align: right;">RIGHT SIDE LIGHTS</th> </tr> </thead> <tbody> <tr><td><input type="checkbox"/></td><td>3</td><td>4</td><td><input type="checkbox"/></td></tr> <tr><td><input type="checkbox"/></td><td>-</td><td>-</td><td><input type="checkbox"/></td></tr> <tr><td><input type="checkbox"/></td><td>3</td><td>2</td><td><input type="checkbox"/></td></tr> <tr><td><input type="checkbox"/></td><td>-</td><td>-</td><td><input type="checkbox"/></td></tr> <tr><td><input type="checkbox"/></td><td>2</td><td>2</td><td><input type="checkbox"/></td></tr> <tr><td><input type="checkbox"/></td><td>-</td><td>-</td><td><input type="checkbox"/></td></tr> <tr><td><input type="checkbox"/></td><td>4</td><td>4</td><td><input type="checkbox"/></td></tr> <tr><td><input type="checkbox"/></td><td>-</td><td>-</td><td><input type="checkbox"/></td></tr> <tr><td><input type="checkbox"/></td><td>1</td><td>1</td><td><input type="checkbox"/></td></tr> <tr><td><input type="checkbox"/></td><td>-</td><td>-</td><td><input type="checkbox"/></td></tr> <tr><td><input type="checkbox"/></td><td>-</td><td>-</td><td><input type="checkbox"/></td></tr> <tr><td><input type="checkbox"/></td><td>-</td><td>-</td><td><input type="checkbox"/></td></tr> <tr><td><input type="checkbox"/></td><td>-</td><td>-</td><td><input type="checkbox"/></td></tr> <tr><td><input type="checkbox"/></td><td>-</td><td>-</td><td><input type="checkbox"/></td></tr> </tbody> </table> | LEFT SIDE LIGHTS | 3 | 4 | RIGHT SIDE LIGHTS | <input type="checkbox"/> | 3 | 4 | <input type="checkbox"/> | <input type="checkbox"/> | - | - | <input type="checkbox"/> | <input type="checkbox"/> | 3 | 2 | <input type="checkbox"/> | <input type="checkbox"/> | - | - | <input type="checkbox"/> | <input type="checkbox"/> | 2 | 2 | <input type="checkbox"/> | <input type="checkbox"/> | - | - | <input type="checkbox"/> | <input type="checkbox"/> | 4 | 4 | <input type="checkbox"/> | <input type="checkbox"/> | - | - | <input type="checkbox"/> | <input type="checkbox"/> | 1 | 1 | <input type="checkbox"/> | <input type="checkbox"/> | - | - | <input type="checkbox"/> | <input type="checkbox"/> | - | - | <input type="checkbox"/> | <input type="checkbox"/> | - | - | <input type="checkbox"/> | <input type="checkbox"/> | - | - | <input type="checkbox"/> | <input type="checkbox"/> | - | - | <input type="checkbox"/> | <p>Four-choice answers, 12 questions, 36 points</p> <p style="text-align: center;">Code: 3016</p> <table style="width: 100%; border-collapse: collapse;"> <thead> <tr> <th style="text-align: left;">LEFT SIDE LIGHTS</th> <th style="text-align: center;">4</th> <th style="text-align: center;">4</th> <th style="text-align: right;">RIGHT SIDE LIGHTS</th> </tr> </thead> <tbody> <tr><td><input type="checkbox"/></td><td>4</td><td>4</td><td><input type="checkbox"/></td></tr> <tr><td><input type="checkbox"/></td><td>-</td><td>-</td><td><input type="checkbox"/></td></tr> <tr><td><input type="checkbox"/></td><td>1</td><td>2</td><td><input type="checkbox"/></td></tr> <tr><td><input type="checkbox"/></td><td>-</td><td>-</td><td><input type="checkbox"/></td></tr> <tr><td><input type="checkbox"/></td><td>3</td><td>3</td><td><input type="checkbox"/></td></tr> <tr><td><input type="checkbox"/></td><td>-</td><td>-</td><td><input type="checkbox"/></td></tr> <tr><td><input type="checkbox"/></td><td>3</td><td>2</td><td><input type="checkbox"/></td></tr> <tr><td><input type="checkbox"/></td><td>-</td><td>-</td><td><input type="checkbox"/></td></tr> <tr><td><input type="checkbox"/></td><td>3</td><td>1</td><td><input type="checkbox"/></td></tr> <tr><td><input type="checkbox"/></td><td>-</td><td>-</td><td><input type="checkbox"/></td></tr> <tr><td><input type="checkbox"/></td><td>3</td><td>4</td><td><input type="checkbox"/></td></tr> <tr><td><input type="checkbox"/></td><td>-</td><td>-</td><td><input type="checkbox"/></td></tr> <tr><td><input type="checkbox"/></td><td>-</td><td>-</td><td><input type="checkbox"/></td></tr> </tbody> </table> | LEFT SIDE LIGHTS | 4 | 4 | RIGHT SIDE LIGHTS | <input type="checkbox"/> | 4 | 4 | <input type="checkbox"/> | <input type="checkbox"/> | - | - | <input type="checkbox"/> | <input type="checkbox"/> | 1 | 2 | <input type="checkbox"/> | <input type="checkbox"/> | - | - | <input type="checkbox"/> | <input type="checkbox"/> | 3 | 3 | <input type="checkbox"/> | <input type="checkbox"/> | - | - | <input type="checkbox"/> | <input type="checkbox"/> | 3 | 2 | <input type="checkbox"/> | <input type="checkbox"/> | - | - | <input type="checkbox"/> | <input type="checkbox"/> | 3 | 1 | <input type="checkbox"/> | <input type="checkbox"/> | - | - | <input type="checkbox"/> | <input type="checkbox"/> | 3 | 4 | <input type="checkbox"/> | <input type="checkbox"/> | - | - | <input type="checkbox"/> | <input type="checkbox"/> | - | - | <input type="checkbox"/> | <p>Four-choice answers, 12 questions, 36 points</p> <p style="text-align: center;">Code: 3495</p> <table style="width: 100%; border-collapse: collapse;"> <thead> <tr> <th style="text-align: left;">LEFT SIDE LIGHTS</th> <th style="text-align: center;">4</th> <th style="text-align: center;">4</th> <th style="text-align: right;">RIGHT SIDE LIGHTS</th> </tr> </thead> <tbody> <tr><td><input type="checkbox"/></td><td>4</td><td>4</td><td><input type="checkbox"/></td></tr> <tr><td><input type="checkbox"/></td><td>-</td><td>-</td><td><input type="checkbox"/></td></tr> <tr><td><input type="checkbox"/></td><td>4</td><td>3</td><td><input type="checkbox"/></td></tr> <tr><td><input type="checkbox"/></td><td>-</td><td>-</td><td><input type="checkbox"/></td></tr> <tr><td><input type="checkbox"/></td><td>2</td><td>2</td><td><input type="checkbox"/></td></tr> <tr><td><input type="checkbox"/></td><td>-</td><td>-</td><td><input type="checkbox"/></td></tr> <tr><td><input type="checkbox"/></td><td>1</td><td>3</td><td><input type="checkbox"/></td></tr> <tr><td><input type="checkbox"/></td><td>-</td><td>-</td><td><input type="checkbox"/></td></tr> <tr><td><input type="checkbox"/></td><td>3</td><td>2</td><td><input type="checkbox"/></td></tr> <tr><td><input type="checkbox"/></td><td>-</td><td>-</td><td><input type="checkbox"/></td></tr> <tr><td><input type="checkbox"/></td><td>1</td><td>1</td><td><input type="checkbox"/></td></tr> <tr><td><input type="checkbox"/></td><td>-</td><td>-</td><td><input type="checkbox"/></td></tr> <tr><td><input type="checkbox"/></td><td>-</td><td>-</td><td><input type="checkbox"/></td></tr> <tr><td><input type="checkbox"/></td><td>-</td><td>-</td><td><input type="checkbox"/></td></tr> </tbody> </table> | LEFT SIDE LIGHTS | 4 | 4 | RIGHT SIDE LIGHTS | <input type="checkbox"/> | 4 | 4 | <input type="checkbox"/> | <input type="checkbox"/> | - | - | <input type="checkbox"/> | <input type="checkbox"/> | 4 | 3 | <input type="checkbox"/> | <input type="checkbox"/> | - | - | <input type="checkbox"/> | <input type="checkbox"/> | 2 | 2 | <input type="checkbox"/> | <input type="checkbox"/> | - | - | <input type="checkbox"/> | <input type="checkbox"/> | 1 | 3 | <input type="checkbox"/> | <input type="checkbox"/> | - | - | <input type="checkbox"/> | <input type="checkbox"/> | 3 | 2 | <input type="checkbox"/> | <input type="checkbox"/> | - | - | <input type="checkbox"/> | <input type="checkbox"/> | 1 | 1 | <input type="checkbox"/> | <input type="checkbox"/> | - | - | <input type="checkbox"/> | <input type="checkbox"/> | - | - | <input type="checkbox"/> | <input type="checkbox"/> | - | - | <input type="checkbox"/> |
|--|------------------------|---|--------------------------|-------------------------|--------------------------|---|---|--------------------------|--------------------------|---|---|--------------------------|--------------------------|---|---|--------------------------|--------------------------|---|---|--------------------------|--------------------------|---|---|--------------------------|--------------------------|---|---|--------------------------|--------------------------|---|---|--------------------------|--------------------------|---|---|--------------------------|--------------------------|---|---|--------------------------|--------------------------|---|---|--------------------------|--------------------------|---|---|--------------------------|--------------------------|---|---|--------------------------|--------------------------|---|---|--------------------------|--|------------------------|---|--------------------------|--|--------------------------|---|---|--------------------------|--------------------------|---|---|--------------------------|--------------------------|---|---|--------------------------|--------------------------|---|---|--------------------------|--------------------------|---|---|--------------------------|--------------------------|---|---|--------------------------|--------------------------|---|---|--------------------------|--------------------------|---|---|--------------------------|--------------------------|---|---|--------------------------|--------------------------|---|---|--------------------------|--------------------------|---|---|--------------------------|--------------------------|---|---|--------------------------|--------------------------|---|---|--------------------------|--|------------------------|---|--------------------------|--------------------------|--------------------------|---|--------------------------|--|--------------------------|---|---|--------------------------|--------------------------|---|---|--------------------------|--------------------------|---|---|--------------------------|--------------------------|---|---|--------------------------|--------------------------|---|---|--------------------------|--------------------------|---|---|--------------------------|--------------------------|---|---|--------------------------|--------------------------|---|---|--------------------------|--------------------------|---|---|--------------------------|--------------------------|---|---|--------------------------|--------------------------|---|---|--------------------------|--------------------------|---|---|--------------------------|--|------------------------|---|--------------------------|--|--------------------------|---|--------------------------|--|--------------------------|---|---|--------------------------|--------------------------|---|---|--------------------------|--------------------------|---|---|--------------------------|--------------------------|---|---|--------------------------|--------------------------|---|---|--------------------------|--------------------------|---|---|--------------------------|--------------------------|---|---|--------------------------|--------------------------|---|---|--------------------------|--------------------------|---|---|--------------------------|--------------------------|---|---|--------------------------|--------------------------|---|---|--------------------------|--------------------------|---|---|--------------------------|--------------------------|---|---|--------------------------|--------------------------|---|---|--------------------------|--------------------------|---|---|--------------------------|
| LEFT SIDE LIGHTS | 2 | 1 | RIGHT SIDE LIGHTS | | | | | | | | | | | | | | | | | | | | | | | | | | | | | | | | | | | | | | | | | | | | | | | | | | | | | | | | | | | | | | | | | | | | | | | | | | | | | | | | | | | | | | | | | | | | | | | | | | | | | | | | | | | | | | | | | | | | | | | | | | | | | | | | | | | | | | | | | | | | | | | | | | | | | | | | | | | | | | | | | | | | | | | | | | | | | | | | | | | | | | | | | | | | | | | | | | | | | | | | | | | | | | | | | | | | | | | | | | | | | | | | | | | | | | | | | | | | |
| <input type="checkbox"/> | 2 | 1 | <input type="checkbox"/> | | | | | | | | | | | | | | | | | | | | | | | | | | | | | | | | | | | | | | | | | | | | | | | | | | | | | | | | | | | | | | | | | | | | | | | | | | | | | | | | | | | | | | | | | | | | | | | | | | | | | | | | | | | | | | | | | | | | | | | | | | | | | | | | | | | | | | | | | | | | | | | | | | | | | | | | | | | | | | | | | | | | | | | | | | | | | | | | | | | | | | | | | | | | | | | | | | | | | | | | | | | | | | | | | | | | | | | | | | | | | | | | | | | | | | | | | | | | |
| <input type="checkbox"/> | - | - | <input type="checkbox"/> | | | | | | | | | | | | | | | | | | | | | | | | | | | | | | | | | | | | | | | | | | | | | | | | | | | | | | | | | | | | | | | | | | | | | | | | | | | | | | | | | | | | | | | | | | | | | | | | | | | | | | | | | | | | | | | | | | | | | | | | | | | | | | | | | | | | | | | | | | | | | | | | | | | | | | | | | | | | | | | | | | | | | | | | | | | | | | | | | | | | | | | | | | | | | | | | | | | | | | | | | | | | | | | | | | | | | | | | | | | | | | | | | | | | | | | | | | | | |
| <input type="checkbox"/> | 4 | 4 | <input type="checkbox"/> | | | | | | | | | | | | | | | | | | | | | | | | | | | | | | | | | | | | | | | | | | | | | | | | | | | | | | | | | | | | | | | | | | | | | | | | | | | | | | | | | | | | | | | | | | | | | | | | | | | | | | | | | | | | | | | | | | | | | | | | | | | | | | | | | | | | | | | | | | | | | | | | | | | | | | | | | | | | | | | | | | | | | | | | | | | | | | | | | | | | | | | | | | | | | | | | | | | | | | | | | | | | | | | | | | | | | | | | | | | | | | | | | | | | | | | | | | | | |
| <input type="checkbox"/> | - | - | <input type="checkbox"/> | | | | | | | | | | | | | | | | | | | | | | | | | | | | | | | | | | | | | | | | | | | | | | | | | | | | | | | | | | | | | | | | | | | | | | | | | | | | | | | | | | | | | | | | | | | | | | | | | | | | | | | | | | | | | | | | | | | | | | | | | | | | | | | | | | | | | | | | | | | | | | | | | | | | | | | | | | | | | | | | | | | | | | | | | | | | | | | | | | | | | | | | | | | | | | | | | | | | | | | | | | | | | | | | | | | | | | | | | | | | | | | | | | | | | | | | | | | | |
| <input type="checkbox"/> | 3 | 1 | <input type="checkbox"/> | | | | | | | | | | | | | | | | | | | | | | | | | | | | | | | | | | | | | | | | | | | | | | | | | | | | | | | | | | | | | | | | | | | | | | | | | | | | | | | | | | | | | | | | | | | | | | | | | | | | | | | | | | | | | | | | | | | | | | | | | | | | | | | | | | | | | | | | | | | | | | | | | | | | | | | | | | | | | | | | | | | | | | | | | | | | | | | | | | | | | | | | | | | | | | | | | | | | | | | | | | | | | | | | | | | | | | | | | | | | | | | | | | | | | | | | | | | | |
| <input type="checkbox"/> | - | - | <input type="checkbox"/> | | | | | | | | | | | | | | | | | | | | | | | | | | | | | | | | | | | | | | | | | | | | | | | | | | | | | | | | | | | | | | | | | | | | | | | | | | | | | | | | | | | | | | | | | | | | | | | | | | | | | | | | | | | | | | | | | | | | | | | | | | | | | | | | | | | | | | | | | | | | | | | | | | | | | | | | | | | | | | | | | | | | | | | | | | | | | | | | | | | | | | | | | | | | | | | | | | | | | | | | | | | | | | | | | | | | | | | | | | | | | | | | | | | | | | | | | | | | |
| <input type="checkbox"/> | 2 | 4 | <input type="checkbox"/> | | | | | | | | | | | | | | | | | | | | | | | | | | | | | | | | | | | | | | | | | | | | | | | | | | | | | | | | | | | | | | | | | | | | | | | | | | | | | | | | | | | | | | | | | | | | | | | | | | | | | | | | | | | | | | | | | | | | | | | | | | | | | | | | | | | | | | | | | | | | | | | | | | | | | | | | | | | | | | | | | | | | | | | | | | | | | | | | | | | | | | | | | | | | | | | | | | | | | | | | | | | | | | | | | | | | | | | | | | | | | | | | | | | | | | | | | | | | |
| <input type="checkbox"/> | - | - | <input type="checkbox"/> | | | | | | | | | | | | | | | | | | | | | | | | | | | | | | | | | | | | | | | | | | | | | | | | | | | | | | | | | | | | | | | | | | | | | | | | | | | | | | | | | | | | | | | | | | | | | | | | | | | | | | | | | | | | | | | | | | | | | | | | | | | | | | | | | | | | | | | | | | | | | | | | | | | | | | | | | | | | | | | | | | | | | | | | | | | | | | | | | | | | | | | | | | | | | | | | | | | | | | | | | | | | | | | | | | | | | | | | | | | | | | | | | | | | | | | | | | | | |
| <input type="checkbox"/> | 3 | 1 | <input type="checkbox"/> | | | | | | | | | | | | | | | | | | | | | | | | | | | | | | | | | | | | | | | | | | | | | | | | | | | | | | | | | | | | | | | | | | | | | | | | | | | | | | | | | | | | | | | | | | | | | | | | | | | | | | | | | | | | | | | | | | | | | | | | | | | | | | | | | | | | | | | | | | | | | | | | | | | | | | | | | | | | | | | | | | | | | | | | | | | | | | | | | | | | | | | | | | | | | | | | | | | | | | | | | | | | | | | | | | | | | | | | | | | | | | | | | | | | | | | | | | | | |
| <input type="checkbox"/> | - | - | <input type="checkbox"/> | | | | | | | | | | | | | | | | | | | | | | | | | | | | | | | | | | | | | | | | | | | | | | | | | | | | | | | | | | | | | | | | | | | | | | | | | | | | | | | | | | | | | | | | | | | | | | | | | | | | | | | | | | | | | | | | | | | | | | | | | | | | | | | | | | | | | | | | | | | | | | | | | | | | | | | | | | | | | | | | | | | | | | | | | | | | | | | | | | | | | | | | | | | | | | | | | | | | | | | | | | | | | | | | | | | | | | | | | | | | | | | | | | | | | | | | | | | | |
| <input type="checkbox"/> | - | - | <input type="checkbox"/> | | | | | | | | | | | | | | | | | | | | | | | | | | | | | | | | | | | | | | | | | | | | | | | | | | | | | | | | | | | | | | | | | | | | | | | | | | | | | | | | | | | | | | | | | | | | | | | | | | | | | | | | | | | | | | | | | | | | | | | | | | | | | | | | | | | | | | | | | | | | | | | | | | | | | | | | | | | | | | | | | | | | | | | | | | | | | | | | | | | | | | | | | | | | | | | | | | | | | | | | | | | | | | | | | | | | | | | | | | | | | | | | | | | | | | | | | | | | |
| <input type="checkbox"/> | - | - | <input type="checkbox"/> | | | | | | | | | | | | | | | | | | | | | | | | | | | | | | | | | | | | | | | | | | | | | | | | | | | | | | | | | | | | | | | | | | | | | | | | | | | | | | | | | | | | | | | | | | | | | | | | | | | | | | | | | | | | | | | | | | | | | | | | | | | | | | | | | | | | | | | | | | | | | | | | | | | | | | | | | | | | | | | | | | | | | | | | | | | | | | | | | | | | | | | | | | | | | | | | | | | | | | | | | | | | | | | | | | | | | | | | | | | | | | | | | | | | | | | | | | | | |
| <input type="checkbox"/> | - | - | <input type="checkbox"/> | | | | | | | | | | | | | | | | | | | | | | | | | | | | | | | | | | | | | | | | | | | | | | | | | | | | | | | | | | | | | | | | | | | | | | | | | | | | | | | | | | | | | | | | | | | | | | | | | | | | | | | | | | | | | | | | | | | | | | | | | | | | | | | | | | | | | | | | | | | | | | | | | | | | | | | | | | | | | | | | | | | | | | | | | | | | | | | | | | | | | | | | | | | | | | | | | | | | | | | | | | | | | | | | | | | | | | | | | | | | | | | | | | | | | | | | | | | | |
| <input type="checkbox"/> | - | - | <input type="checkbox"/> | | | | | | | | | | | | | | | | | | | | | | | | | | | | | | | | | | | | | | | | | | | | | | | | | | | | | | | | | | | | | | | | | | | | | | | | | | | | | | | | | | | | | | | | | | | | | | | | | | | | | | | | | | | | | | | | | | | | | | | | | | | | | | | | | | | | | | | | | | | | | | | | | | | | | | | | | | | | | | | | | | | | | | | | | | | | | | | | | | | | | | | | | | | | | | | | | | | | | | | | | | | | | | | | | | | | | | | | | | | | | | | | | | | | | | | | | | | | |
| LEFT SIDE LIGHTS | 3 | 4 | RIGHT SIDE LIGHTS | | | | | | | | | | | | | | | | | | | | | | | | | | | | | | | | | | | | | | | | | | | | | | | | | | | | | | | | | | | | | | | | | | | | | | | | | | | | | | | | | | | | | | | | | | | | | | | | | | | | | | | | | | | | | | | | | | | | | | | | | | | | | | | | | | | | | | | | | | | | | | | | | | | | | | | | | | | | | | | | | | | | | | | | | | | | | | | | | | | | | | | | | | | | | | | | | | | | | | | | | | | | | | | | | | | | | | | | | | | | | | | | | | | | | | | | | | | | |
| <input type="checkbox"/> | 3 | 4 | <input type="checkbox"/> | | | | | | | | | | | | | | | | | | | | | | | | | | | | | | | | | | | | | | | | | | | | | | | | | | | | | | | | | | | | | | | | | | | | | | | | | | | | | | | | | | | | | | | | | | | | | | | | | | | | | | | | | | | | | | | | | | | | | | | | | | | | | | | | | | | | | | | | | | | | | | | | | | | | | | | | | | | | | | | | | | | | | | | | | | | | | | | | | | | | | | | | | | | | | | | | | | | | | | | | | | | | | | | | | | | | | | | | | | | | | | | | | | | | | | | | | | | | |
| <input type="checkbox"/> | - | - | <input type="checkbox"/> | | | | | | | | | | | | | | | | | | | | | | | | | | | | | | | | | | | | | | | | | | | | | | | | | | | | | | | | | | | | | | | | | | | | | | | | | | | | | | | | | | | | | | | | | | | | | | | | | | | | | | | | | | | | | | | | | | | | | | | | | | | | | | | | | | | | | | | | | | | | | | | | | | | | | | | | | | | | | | | | | | | | | | | | | | | | | | | | | | | | | | | | | | | | | | | | | | | | | | | | | | | | | | | | | | | | | | | | | | | | | | | | | | | | | | | | | | | | |
| <input type="checkbox"/> | 3 | 2 | <input type="checkbox"/> | | | | | | | | | | | | | | | | | | | | | | | | | | | | | | | | | | | | | | | | | | | | | | | | | | | | | | | | | | | | | | | | | | | | | | | | | | | | | | | | | | | | | | | | | | | | | | | | | | | | | | | | | | | | | | | | | | | | | | | | | | | | | | | | | | | | | | | | | | | | | | | | | | | | | | | | | | | | | | | | | | | | | | | | | | | | | | | | | | | | | | | | | | | | | | | | | | | | | | | | | | | | | | | | | | | | | | | | | | | | | | | | | | | | | | | | | | | | |
| <input type="checkbox"/> | - | - | <input type="checkbox"/> | | | | | | | | | | | | | | | | | | | | | | | | | | | | | | | | | | | | | | | | | | | | | | | | | | | | | | | | | | | | | | | | | | | | | | | | | | | | | | | | | | | | | | | | | | | | | | | | | | | | | | | | | | | | | | | | | | | | | | | | | | | | | | | | | | | | | | | | | | | | | | | | | | | | | | | | | | | | | | | | | | | | | | | | | | | | | | | | | | | | | | | | | | | | | | | | | | | | | | | | | | | | | | | | | | | | | | | | | | | | | | | | | | | | | | | | | | | | |
| <input type="checkbox"/> | 2 | 2 | <input type="checkbox"/> | | | | | | | | | | | | | | | | | | | | | | | | | | | | | | | | | | | | | | | | | | | | | | | | | | | | | | | | | | | | | | | | | | | | | | | | | | | | | | | | | | | | | | | | | | | | | | | | | | | | | | | | | | | | | | | | | | | | | | | | | | | | | | | | | | | | | | | | | | | | | | | | | | | | | | | | | | | | | | | | | | | | | | | | | | | | | | | | | | | | | | | | | | | | | | | | | | | | | | | | | | | | | | | | | | | | | | | | | | | | | | | | | | | | | | | | | | | | |
| <input type="checkbox"/> | - | - | <input type="checkbox"/> | | | | | | | | | | | | | | | | | | | | | | | | | | | | | | | | | | | | | | | | | | | | | | | | | | | | | | | | | | | | | | | | | | | | | | | | | | | | | | | | | | | | | | | | | | | | | | | | | | | | | | | | | | | | | | | | | | | | | | | | | | | | | | | | | | | | | | | | | | | | | | | | | | | | | | | | | | | | | | | | | | | | | | | | | | | | | | | | | | | | | | | | | | | | | | | | | | | | | | | | | | | | | | | | | | | | | | | | | | | | | | | | | | | | | | | | | | | | |
| <input type="checkbox"/> | 4 | 4 | <input type="checkbox"/> | | | | | | | | | | | | | | | | | | | | | | | | | | | | | | | | | | | | | | | | | | | | | | | | | | | | | | | | | | | | | | | | | | | | | | | | | | | | | | | | | | | | | | | | | | | | | | | | | | | | | | | | | | | | | | | | | | | | | | | | | | | | | | | | | | | | | | | | | | | | | | | | | | | | | | | | | | | | | | | | | | | | | | | | | | | | | | | | | | | | | | | | | | | | | | | | | | | | | | | | | | | | | | | | | | | | | | | | | | | | | | | | | | | | | | | | | | | | |
| <input type="checkbox"/> | - | - | <input type="checkbox"/> | | | | | | | | | | | | | | | | | | | | | | | | | | | | | | | | | | | | | | | | | | | | | | | | | | | | | | | | | | | | | | | | | | | | | | | | | | | | | | | | | | | | | | | | | | | | | | | | | | | | | | | | | | | | | | | | | | | | | | | | | | | | | | | | | | | | | | | | | | | | | | | | | | | | | | | | | | | | | | | | | | | | | | | | | | | | | | | | | | | | | | | | | | | | | | | | | | | | | | | | | | | | | | | | | | | | | | | | | | | | | | | | | | | | | | | | | | | | |
| <input type="checkbox"/> | 1 | 1 | <input type="checkbox"/> | | | | | | | | | | | | | | | | | | | | | | | | | | | | | | | | | | | | | | | | | | | | | | | | | | | | | | | | | | | | | | | | | | | | | | | | | | | | | | | | | | | | | | | | | | | | | | | | | | | | | | | | | | | | | | | | | | | | | | | | | | | | | | | | | | | | | | | | | | | | | | | | | | | | | | | | | | | | | | | | | | | | | | | | | | | | | | | | | | | | | | | | | | | | | | | | | | | | | | | | | | | | | | | | | | | | | | | | | | | | | | | | | | | | | | | | | | | | |
| <input type="checkbox"/> | - | - | <input type="checkbox"/> | | | | | | | | | | | | | | | | | | | | | | | | | | | | | | | | | | | | | | | | | | | | | | | | | | | | | | | | | | | | | | | | | | | | | | | | | | | | | | | | | | | | | | | | | | | | | | | | | | | | | | | | | | | | | | | | | | | | | | | | | | | | | | | | | | | | | | | | | | | | | | | | | | | | | | | | | | | | | | | | | | | | | | | | | | | | | | | | | | | | | | | | | | | | | | | | | | | | | | | | | | | | | | | | | | | | | | | | | | | | | | | | | | | | | | | | | | | | |
| <input type="checkbox"/> | - | - | <input type="checkbox"/> | | | | | | | | | | | | | | | | | | | | | | | | | | | | | | | | | | | | | | | | | | | | | | | | | | | | | | | | | | | | | | | | | | | | | | | | | | | | | | | | | | | | | | | | | | | | | | | | | | | | | | | | | | | | | | | | | | | | | | | | | | | | | | | | | | | | | | | | | | | | | | | | | | | | | | | | | | | | | | | | | | | | | | | | | | | | | | | | | | | | | | | | | | | | | | | | | | | | | | | | | | | | | | | | | | | | | | | | | | | | | | | | | | | | | | | | | | | | |
| <input type="checkbox"/> | - | - | <input type="checkbox"/> | | | | | | | | | | | | | | | | | | | | | | | | | | | | | | | | | | | | | | | | | | | | | | | | | | | | | | | | | | | | | | | | | | | | | | | | | | | | | | | | | | | | | | | | | | | | | | | | | | | | | | | | | | | | | | | | | | | | | | | | | | | | | | | | | | | | | | | | | | | | | | | | | | | | | | | | | | | | | | | | | | | | | | | | | | | | | | | | | | | | | | | | | | | | | | | | | | | | | | | | | | | | | | | | | | | | | | | | | | | | | | | | | | | | | | | | | | | | |
| <input type="checkbox"/> | - | - | <input type="checkbox"/> | | | | | | | | | | | | | | | | | | | | | | | | | | | | | | | | | | | | | | | | | | | | | | | | | | | | | | | | | | | | | | | | | | | | | | | | | | | | | | | | | | | | | | | | | | | | | | | | | | | | | | | | | | | | | | | | | | | | | | | | | | | | | | | | | | | | | | | | | | | | | | | | | | | | | | | | | | | | | | | | | | | | | | | | | | | | | | | | | | | | | | | | | | | | | | | | | | | | | | | | | | | | | | | | | | | | | | | | | | | | | | | | | | | | | | | | | | | | |
| <input type="checkbox"/> | - | - | <input type="checkbox"/> | | | | | | | | | | | | | | | | | | | | | | | | | | | | | | | | | | | | | | | | | | | | | | | | | | | | | | | | | | | | | | | | | | | | | | | | | | | | | | | | | | | | | | | | | | | | | | | | | | | | | | | | | | | | | | | | | | | | | | | | | | | | | | | | | | | | | | | | | | | | | | | | | | | | | | | | | | | | | | | | | | | | | | | | | | | | | | | | | | | | | | | | | | | | | | | | | | | | | | | | | | | | | | | | | | | | | | | | | | | | | | | | | | | | | | | | | | | | |
| LEFT SIDE LIGHTS | 4 | 4 | RIGHT SIDE LIGHTS | | | | | | | | | | | | | | | | | | | | | | | | | | | | | | | | | | | | | | | | | | | | | | | | | | | | | | | | | | | | | | | | | | | | | | | | | | | | | | | | | | | | | | | | | | | | | | | | | | | | | | | | | | | | | | | | | | | | | | | | | | | | | | | | | | | | | | | | | | | | | | | | | | | | | | | | | | | | | | | | | | | | | | | | | | | | | | | | | | | | | | | | | | | | | | | | | | | | | | | | | | | | | | | | | | | | | | | | | | | | | | | | | | | | | | | | | | | | |
| <input type="checkbox"/> | 4 | 4 | <input type="checkbox"/> | | | | | | | | | | | | | | | | | | | | | | | | | | | | | | | | | | | | | | | | | | | | | | | | | | | | | | | | | | | | | | | | | | | | | | | | | | | | | | | | | | | | | | | | | | | | | | | | | | | | | | | | | | | | | | | | | | | | | | | | | | | | | | | | | | | | | | | | | | | | | | | | | | | | | | | | | | | | | | | | | | | | | | | | | | | | | | | | | | | | | | | | | | | | | | | | | | | | | | | | | | | | | | | | | | | | | | | | | | | | | | | | | | | | | | | | | | | | |
| <input type="checkbox"/> | - | - | <input type="checkbox"/> | | | | | | | | | | | | | | | | | | | | | | | | | | | | | | | | | | | | | | | | | | | | | | | | | | | | | | | | | | | | | | | | | | | | | | | | | | | | | | | | | | | | | | | | | | | | | | | | | | | | | | | | | | | | | | | | | | | | | | | | | | | | | | | | | | | | | | | | | | | | | | | | | | | | | | | | | | | | | | | | | | | | | | | | | | | | | | | | | | | | | | | | | | | | | | | | | | | | | | | | | | | | | | | | | | | | | | | | | | | | | | | | | | | | | | | | | | | | |
| <input type="checkbox"/> | 1 | 2 | <input type="checkbox"/> | | | | | | | | | | | | | | | | | | | | | | | | | | | | | | | | | | | | | | | | | | | | | | | | | | | | | | | | | | | | | | | | | | | | | | | | | | | | | | | | | | | | | | | | | | | | | | | | | | | | | | | | | | | | | | | | | | | | | | | | | | | | | | | | | | | | | | | | | | | | | | | | | | | | | | | | | | | | | | | | | | | | | | | | | | | | | | | | | | | | | | | | | | | | | | | | | | | | | | | | | | | | | | | | | | | | | | | | | | | | | | | | | | | | | | | | | | | | |
| <input type="checkbox"/> | - | - | <input type="checkbox"/> | | | | | | | | | | | | | | | | | | | | | | | | | | | | | | | | | | | | | | | | | | | | | | | | | | | | | | | | | | | | | | | | | | | | | | | | | | | | | | | | | | | | | | | | | | | | | | | | | | | | | | | | | | | | | | | | | | | | | | | | | | | | | | | | | | | | | | | | | | | | | | | | | | | | | | | | | | | | | | | | | | | | | | | | | | | | | | | | | | | | | | | | | | | | | | | | | | | | | | | | | | | | | | | | | | | | | | | | | | | | | | | | | | | | | | | | | | | | |
| <input type="checkbox"/> | 3 | 3 | <input type="checkbox"/> | | | | | | | | | | | | | | | | | | | | | | | | | | | | | | | | | | | | | | | | | | | | | | | | | | | | | | | | | | | | | | | | | | | | | | | | | | | | | | | | | | | | | | | | | | | | | | | | | | | | | | | | | | | | | | | | | | | | | | | | | | | | | | | | | | | | | | | | | | | | | | | | | | | | | | | | | | | | | | | | | | | | | | | | | | | | | | | | | | | | | | | | | | | | | | | | | | | | | | | | | | | | | | | | | | | | | | | | | | | | | | | | | | | | | | | | | | | | |
| <input type="checkbox"/> | - | - | <input type="checkbox"/> | | | | | | | | | | | | | | | | | | | | | | | | | | | | | | | | | | | | | | | | | | | | | | | | | | | | | | | | | | | | | | | | | | | | | | | | | | | | | | | | | | | | | | | | | | | | | | | | | | | | | | | | | | | | | | | | | | | | | | | | | | | | | | | | | | | | | | | | | | | | | | | | | | | | | | | | | | | | | | | | | | | | | | | | | | | | | | | | | | | | | | | | | | | | | | | | | | | | | | | | | | | | | | | | | | | | | | | | | | | | | | | | | | | | | | | | | | | | |
| <input type="checkbox"/> | 3 | 2 | <input type="checkbox"/> | | | | | | | | | | | | | | | | | | | | | | | | | | | | | | | | | | | | | | | | | | | | | | | | | | | | | | | | | | | | | | | | | | | | | | | | | | | | | | | | | | | | | | | | | | | | | | | | | | | | | | | | | | | | | | | | | | | | | | | | | | | | | | | | | | | | | | | | | | | | | | | | | | | | | | | | | | | | | | | | | | | | | | | | | | | | | | | | | | | | | | | | | | | | | | | | | | | | | | | | | | | | | | | | | | | | | | | | | | | | | | | | | | | | | | | | | | | | |
| <input type="checkbox"/> | - | - | <input type="checkbox"/> | | | | | | | | | | | | | | | | | | | | | | | | | | | | | | | | | | | | | | | | | | | | | | | | | | | | | | | | | | | | | | | | | | | | | | | | | | | | | | | | | | | | | | | | | | | | | | | | | | | | | | | | | | | | | | | | | | | | | | | | | | | | | | | | | | | | | | | | | | | | | | | | | | | | | | | | | | | | | | | | | | | | | | | | | | | | | | | | | | | | | | | | | | | | | | | | | | | | | | | | | | | | | | | | | | | | | | | | | | | | | | | | | | | | | | | | | | | | |
| <input type="checkbox"/> | 3 | 1 | <input type="checkbox"/> | | | | | | | | | | | | | | | | | | | | | | | | | | | | | | | | | | | | | | | | | | | | | | | | | | | | | | | | | | | | | | | | | | | | | | | | | | | | | | | | | | | | | | | | | | | | | | | | | | | | | | | | | | | | | | | | | | | | | | | | | | | | | | | | | | | | | | | | | | | | | | | | | | | | | | | | | | | | | | | | | | | | | | | | | | | | | | | | | | | | | | | | | | | | | | | | | | | | | | | | | | | | | | | | | | | | | | | | | | | | | | | | | | | | | | | | | | | | |
| <input type="checkbox"/> | - | - | <input type="checkbox"/> | | | | | | | | | | | | | | | | | | | | | | | | | | | | | | | | | | | | | | | | | | | | | | | | | | | | | | | | | | | | | | | | | | | | | | | | | | | | | | | | | | | | | | | | | | | | | | | | | | | | | | | | | | | | | | | | | | | | | | | | | | | | | | | | | | | | | | | | | | | | | | | | | | | | | | | | | | | | | | | | | | | | | | | | | | | | | | | | | | | | | | | | | | | | | | | | | | | | | | | | | | | | | | | | | | | | | | | | | | | | | | | | | | | | | | | | | | | | |
| <input type="checkbox"/> | 3 | 4 | <input type="checkbox"/> | | | | | | | | | | | | | | | | | | | | | | | | | | | | | | | | | | | | | | | | | | | | | | | | | | | | | | | | | | | | | | | | | | | | | | | | | | | | | | | | | | | | | | | | | | | | | | | | | | | | | | | | | | | | | | | | | | | | | | | | | | | | | | | | | | | | | | | | | | | | | | | | | | | | | | | | | | | | | | | | | | | | | | | | | | | | | | | | | | | | | | | | | | | | | | | | | | | | | | | | | | | | | | | | | | | | | | | | | | | | | | | | | | | | | | | | | | | | |
| <input type="checkbox"/> | - | - | <input type="checkbox"/> | | | | | | | | | | | | | | | | | | | | | | | | | | | | | | | | | | | | | | | | | | | | | | | | | | | | | | | | | | | | | | | | | | | | | | | | | | | | | | | | | | | | | | | | | | | | | | | | | | | | | | | | | | | | | | | | | | | | | | | | | | | | | | | | | | | | | | | | | | | | | | | | | | | | | | | | | | | | | | | | | | | | | | | | | | | | | | | | | | | | | | | | | | | | | | | | | | | | | | | | | | | | | | | | | | | | | | | | | | | | | | | | | | | | | | | | | | | | |
| <input type="checkbox"/> | - | - | <input type="checkbox"/> | | | | | | | | | | | | | | | | | | | | | | | | | | | | | | | | | | | | | | | | | | | | | | | | | | | | | | | | | | | | | | | | | | | | | | | | | | | | | | | | | | | | | | | | | | | | | | | | | | | | | | | | | | | | | | | | | | | | | | | | | | | | | | | | | | | | | | | | | | | | | | | | | | | | | | | | | | | | | | | | | | | | | | | | | | | | | | | | | | | | | | | | | | | | | | | | | | | | | | | | | | | | | | | | | | | | | | | | | | | | | | | | | | | | | | | | | | | | |
| LEFT SIDE LIGHTS | 4 | 4 | RIGHT SIDE LIGHTS | | | | | | | | | | | | | | | | | | | | | | | | | | | | | | | | | | | | | | | | | | | | | | | | | | | | | | | | | | | | | | | | | | | | | | | | | | | | | | | | | | | | | | | | | | | | | | | | | | | | | | | | | | | | | | | | | | | | | | | | | | | | | | | | | | | | | | | | | | | | | | | | | | | | | | | | | | | | | | | | | | | | | | | | | | | | | | | | | | | | | | | | | | | | | | | | | | | | | | | | | | | | | | | | | | | | | | | | | | | | | | | | | | | | | | | | | | | | |
| <input type="checkbox"/> | 4 | 4 | <input type="checkbox"/> | | | | | | | | | | | | | | | | | | | | | | | | | | | | | | | | | | | | | | | | | | | | | | | | | | | | | | | | | | | | | | | | | | | | | | | | | | | | | | | | | | | | | | | | | | | | | | | | | | | | | | | | | | | | | | | | | | | | | | | | | | | | | | | | | | | | | | | | | | | | | | | | | | | | | | | | | | | | | | | | | | | | | | | | | | | | | | | | | | | | | | | | | | | | | | | | | | | | | | | | | | | | | | | | | | | | | | | | | | | | | | | | | | | | | | | | | | | | |
| <input type="checkbox"/> | - | - | <input type="checkbox"/> | | | | | | | | | | | | | | | | | | | | | | | | | | | | | | | | | | | | | | | | | | | | | | | | | | | | | | | | | | | | | | | | | | | | | | | | | | | | | | | | | | | | | | | | | | | | | | | | | | | | | | | | | | | | | | | | | | | | | | | | | | | | | | | | | | | | | | | | | | | | | | | | | | | | | | | | | | | | | | | | | | | | | | | | | | | | | | | | | | | | | | | | | | | | | | | | | | | | | | | | | | | | | | | | | | | | | | | | | | | | | | | | | | | | | | | | | | | | |
| <input type="checkbox"/> | 4 | 3 | <input type="checkbox"/> | | | | | | | | | | | | | | | | | | | | | | | | | | | | | | | | | | | | | | | | | | | | | | | | | | | | | | | | | | | | | | | | | | | | | | | | | | | | | | | | | | | | | | | | | | | | | | | | | | | | | | | | | | | | | | | | | | | | | | | | | | | | | | | | | | | | | | | | | | | | | | | | | | | | | | | | | | | | | | | | | | | | | | | | | | | | | | | | | | | | | | | | | | | | | | | | | | | | | | | | | | | | | | | | | | | | | | | | | | | | | | | | | | | | | | | | | | | | |
| <input type="checkbox"/> | - | - | <input type="checkbox"/> | | | | | | | | | | | | | | | | | | | | | | | | | | | | | | | | | | | | | | | | | | | | | | | | | | | | | | | | | | | | | | | | | | | | | | | | | | | | | | | | | | | | | | | | | | | | | | | | | | | | | | | | | | | | | | | | | | | | | | | | | | | | | | | | | | | | | | | | | | | | | | | | | | | | | | | | | | | | | | | | | | | | | | | | | | | | | | | | | | | | | | | | | | | | | | | | | | | | | | | | | | | | | | | | | | | | | | | | | | | | | | | | | | | | | | | | | | | | |
| <input type="checkbox"/> | 2 | 2 | <input type="checkbox"/> | | | | | | | | | | | | | | | | | | | | | | | | | | | | | | | | | | | | | | | | | | | | | | | | | | | | | | | | | | | | | | | | | | | | | | | | | | | | | | | | | | | | | | | | | | | | | | | | | | | | | | | | | | | | | | | | | | | | | | | | | | | | | | | | | | | | | | | | | | | | | | | | | | | | | | | | | | | | | | | | | | | | | | | | | | | | | | | | | | | | | | | | | | | | | | | | | | | | | | | | | | | | | | | | | | | | | | | | | | | | | | | | | | | | | | | | | | | | |
| <input type="checkbox"/> | - | - | <input type="checkbox"/> | | | | | | | | | | | | | | | | | | | | | | | | | | | | | | | | | | | | | | | | | | | | | | | | | | | | | | | | | | | | | | | | | | | | | | | | | | | | | | | | | | | | | | | | | | | | | | | | | | | | | | | | | | | | | | | | | | | | | | | | | | | | | | | | | | | | | | | | | | | | | | | | | | | | | | | | | | | | | | | | | | | | | | | | | | | | | | | | | | | | | | | | | | | | | | | | | | | | | | | | | | | | | | | | | | | | | | | | | | | | | | | | | | | | | | | | | | | | |
| <input type="checkbox"/> | 1 | 3 | <input type="checkbox"/> | | | | | | | | | | | | | | | | | | | | | | | | | | | | | | | | | | | | | | | | | | | | | | | | | | | | | | | | | | | | | | | | | | | | | | | | | | | | | | | | | | | | | | | | | | | | | | | | | | | | | | | | | | | | | | | | | | | | | | | | | | | | | | | | | | | | | | | | | | | | | | | | | | | | | | | | | | | | | | | | | | | | | | | | | | | | | | | | | | | | | | | | | | | | | | | | | | | | | | | | | | | | | | | | | | | | | | | | | | | | | | | | | | | | | | | | | | | | |
| <input type="checkbox"/> | - | - | <input type="checkbox"/> | | | | | | | | | | | | | | | | | | | | | | | | | | | | | | | | | | | | | | | | | | | | | | | | | | | | | | | | | | | | | | | | | | | | | | | | | | | | | | | | | | | | | | | | | | | | | | | | | | | | | | | | | | | | | | | | | | | | | | | | | | | | | | | | | | | | | | | | | | | | | | | | | | | | | | | | | | | | | | | | | | | | | | | | | | | | | | | | | | | | | | | | | | | | | | | | | | | | | | | | | | | | | | | | | | | | | | | | | | | | | | | | | | | | | | | | | | | | |
| <input type="checkbox"/> | 3 | 2 | <input type="checkbox"/> | | | | | | | | | | | | | | | | | | | | | | | | | | | | | | | | | | | | | | | | | | | | | | | | | | | | | | | | | | | | | | | | | | | | | | | | | | | | | | | | | | | | | | | | | | | | | | | | | | | | | | | | | | | | | | | | | | | | | | | | | | | | | | | | | | | | | | | | | | | | | | | | | | | | | | | | | | | | | | | | | | | | | | | | | | | | | | | | | | | | | | | | | | | | | | | | | | | | | | | | | | | | | | | | | | | | | | | | | | | | | | | | | | | | | | | | | | | | |
| <input type="checkbox"/> | - | - | <input type="checkbox"/> | | | | | | | | | | | | | | | | | | | | | | | | | | | | | | | | | | | | | | | | | | | | | | | | | | | | | | | | | | | | | | | | | | | | | | | | | | | | | | | | | | | | | | | | | | | | | | | | | | | | | | | | | | | | | | | | | | | | | | | | | | | | | | | | | | | | | | | | | | | | | | | | | | | | | | | | | | | | | | | | | | | | | | | | | | | | | | | | | | | | | | | | | | | | | | | | | | | | | | | | | | | | | | | | | | | | | | | | | | | | | | | | | | | | | | | | | | | | |
| <input type="checkbox"/> | 1 | 1 | <input type="checkbox"/> | | | | | | | | | | | | | | | | | | | | | | | | | | | | | | | | | | | | | | | | | | | | | | | | | | | | | | | | | | | | | | | | | | | | | | | | | | | | | | | | | | | | | | | | | | | | | | | | | | | | | | | | | | | | | | | | | | | | | | | | | | | | | | | | | | | | | | | | | | | | | | | | | | | | | | | | | | | | | | | | | | | | | | | | | | | | | | | | | | | | | | | | | | | | | | | | | | | | | | | | | | | | | | | | | | | | | | | | | | | | | | | | | | | | | | | | | | | | |
| <input type="checkbox"/> | - | - | <input type="checkbox"/> | | | | | | | | | | | | | | | | | | | | | | | | | | | | | | | | | | | | | | | | | | | | | | | | | | | | | | | | | | | | | | | | | | | | | | | | | | | | | | | | | | | | | | | | | | | | | | | | | | | | | | | | | | | | | | | | | | | | | | | | | | | | | | | | | | | | | | | | | | | | | | | | | | | | | | | | | | | | | | | | | | | | | | | | | | | | | | | | | | | | | | | | | | | | | | | | | | | | | | | | | | | | | | | | | | | | | | | | | | | | | | | | | | | | | | | | | | | | |
| <input type="checkbox"/> | - | - | <input type="checkbox"/> | | | | | | | | | | | | | | | | | | | | | | | | | | | | | | | | | | | | | | | | | | | | | | | | | | | | | | | | | | | | | | | | | | | | | | | | | | | | | | | | | | | | | | | | | | | | | | | | | | | | | | | | | | | | | | | | | | | | | | | | | | | | | | | | | | | | | | | | | | | | | | | | | | | | | | | | | | | | | | | | | | | | | | | | | | | | | | | | | | | | | | | | | | | | | | | | | | | | | | | | | | | | | | | | | | | | | | | | | | | | | | | | | | | | | | | | | | | | |
| <input type="checkbox"/> | - | - | <input type="checkbox"/> | | | | | | | | | | | | | | | | | | | | | | | | | | | | | | | | | | | | | | | | | | | | | | | | | | | | | | | | | | | | | | | | | | | | | | | | | | | | | | | | | | | | | | | | | | | | | | | | | | | | | | | | | | | | | | | | | | | | | | | | | | | | | | | | | | | | | | | | | | | | | | | | | | | | | | | | | | | | | | | | | | | | | | | | | | | | | | | | | | | | | | | | | | | | | | | | | | | | | | | | | | | | | | | | | | | | | | | | | | | | | | | | | | | | | | | | | | | | |
| <p>Four-choice answers, 14 questions, 42 points</p> <p style="text-align: center;">Code: 4505</p> <table style="width: 100%; border-collapse: collapse;"> <thead> <tr> <th style="text-align: left;">LEFT SIDE LIGHTS</th> <th style="text-align: center;">2</th> <th style="text-align: center;">3</th> <th style="text-align: right;">RIGHT SIDE LIGHTS</th> </tr> </thead> <tbody> <tr><td><input type="checkbox"/></td><td>2</td><td>3</td><td><input type="checkbox"/></td></tr> <tr><td><input type="checkbox"/></td><td>-</td><td>-</td><td><input type="checkbox"/></td></tr> <tr><td><input type="checkbox"/></td><td>2</td><td>4</td><td><input type="checkbox"/></td></tr> <tr><td><input type="checkbox"/></td><td>-</td><td>-</td><td><input type="checkbox"/></td></tr> <tr><td><input type="checkbox"/></td><td>4</td><td>2</td><td><input type="checkbox"/></td></tr> <tr><td><input type="checkbox"/></td><td>-</td><td>-</td><td><input type="checkbox"/></td></tr> <tr><td><input type="checkbox"/></td><td>3</td><td>3</td><td><input type="checkbox"/></td></tr> <tr><td><input type="checkbox"/></td><td>-</td><td>-</td><td><input type="checkbox"/></td></tr> <tr><td><input type="checkbox"/></td><td>1</td><td>2</td><td><input type="checkbox"/></td></tr> <tr><td><input type="checkbox"/></td><td>-</td><td>-</td><td><input type="checkbox"/></td></tr> <tr><td><input type="checkbox"/></td><td>4</td><td>1</td><td><input type="checkbox"/></td></tr> <tr><td><input type="checkbox"/></td><td>-</td><td>-</td><td><input type="checkbox"/></td></tr> <tr><td><input type="checkbox"/></td><td>1</td><td>4</td><td><input type="checkbox"/></td></tr> </tbody> </table> | LEFT SIDE LIGHTS | 2 | 3 | RIGHT SIDE LIGHTS | <input type="checkbox"/> | 2 | 3 | <input type="checkbox"/> | <input type="checkbox"/> | - | - | <input type="checkbox"/> | <input type="checkbox"/> | 2 | 4 | <input type="checkbox"/> | <input type="checkbox"/> | - | - | <input type="checkbox"/> | <input type="checkbox"/> | 4 | 2 | <input type="checkbox"/> | <input type="checkbox"/> | - | - | <input type="checkbox"/> | <input type="checkbox"/> | 3 | 3 | <input type="checkbox"/> | <input type="checkbox"/> | - | - | <input type="checkbox"/> | <input type="checkbox"/> | 1 | 2 | <input type="checkbox"/> | <input type="checkbox"/> | - | - | <input type="checkbox"/> | <input type="checkbox"/> | 4 | 1 | <input type="checkbox"/> | <input type="checkbox"/> | - | - | <input type="checkbox"/> | <input type="checkbox"/> | 1 | 4 | <input type="checkbox"/> | <p>Four-choice answers, 14 questions, 42 points</p> <p style="text-align: center;">Code: 4968</p> <table style="width: 100%; border-collapse: collapse;"> <thead> <tr> <th style="text-align: left;">LEFT SIDE LIGHTS</th> <th style="text-align: center;">1</th> <th style="text-align: center;">4</th> <th style="text-align: right;">RIGHT SIDE LIGHTS</th> </tr> </thead> <tbody> <tr><td><input type="checkbox"/></td><td>1</td><td>4</td><td><input type="checkbox"/></td></tr> <tr><td><input type="checkbox"/></td><td>-</td><td>-</td><td><input type="checkbox"/></td></tr> <tr><td><input type="checkbox"/></td><td>2</td><td>2</td><td><input type="checkbox"/></td></tr> <tr><td><input type="checkbox"/></td><td>-</td><td>-</td><td><input type="checkbox"/></td></tr> <tr><td><input type="checkbox"/></td><td>3</td><td>4</td><td><input type="checkbox"/></td></tr> <tr><td><input type="checkbox"/></td><td>-</td><td>-</td><td><input type="checkbox"/></td></tr> <tr><td><input type="checkbox"/></td><td>1</td><td>4</td><td><input type="checkbox"/></td></tr> <tr><td><input type="checkbox"/></td><td>-</td><td>-</td><td><input type="checkbox"/></td></tr> <tr><td><input type="checkbox"/></td><td>1</td><td>2</td><td><input type="checkbox"/></td></tr> <tr><td><input type="checkbox"/></td><td>-</td><td>-</td><td><input type="checkbox"/></td></tr> <tr><td><input type="checkbox"/></td><td>1</td><td>3</td><td><input type="checkbox"/></td></tr> <tr><td><input type="checkbox"/></td><td>-</td><td>-</td><td><input type="checkbox"/></td></tr> <tr><td><input type="checkbox"/></td><td>3</td><td>4</td><td><input type="checkbox"/></td></tr> </tbody> </table> | LEFT SIDE LIGHTS | 1 | 4 | RIGHT SIDE LIGHTS | <input type="checkbox"/> | 1 | 4 | <input type="checkbox"/> | <input type="checkbox"/> | - | - | <input type="checkbox"/> | <input type="checkbox"/> | 2 | 2 | <input type="checkbox"/> | <input type="checkbox"/> | - | - | <input type="checkbox"/> | <input type="checkbox"/> | 3 | 4 | <input type="checkbox"/> | <input type="checkbox"/> | - | - | <input type="checkbox"/> | <input type="checkbox"/> | 1 | 4 | <input type="checkbox"/> | <input type="checkbox"/> | - | - | <input type="checkbox"/> | <input type="checkbox"/> | 1 | 2 | <input type="checkbox"/> | <input type="checkbox"/> | - | - | <input type="checkbox"/> | <input type="checkbox"/> | 1 | 3 | <input type="checkbox"/> | <input type="checkbox"/> | - | - | <input type="checkbox"/> | <input type="checkbox"/> | 3 | 4 | <input type="checkbox"/> | <p>Four-choice answers, 16 questions, 48 points</p> <p style="text-align: center;">Code: 6014</p> <table style="width: 100%; border-collapse: collapse;"> <thead> <tr> <th style="text-align: left;">LEFT SIDE LIGHTS</th> <th style="text-align: center;">3</th> <th style="text-align: center;">3</th> <th style="text-align: right;">RIGHT SIDE LIGHTS</th> </tr> </thead> <tbody> <tr><td><input type="checkbox"/></td><td>3</td><td>3</td><td><input type="checkbox"/></td></tr> <tr><td><input type="checkbox"/></td><td>2</td><td>4</td><td><input type="checkbox"/></td></tr> <tr><td><input type="checkbox"/></td><td>2</td><td>2</td><td><input type="checkbox"/></td></tr> <tr><td><input type="checkbox"/></td><td>2</td><td>3</td><td><input type="checkbox"/></td></tr> <tr><td><input type="checkbox"/></td><td>1</td><td>4</td><td><input type="checkbox"/></td></tr> <tr><td><input type="checkbox"/></td><td>1</td><td>1</td><td><input type="checkbox"/></td></tr> <tr><td><input type="checkbox"/></td><td>3</td><td>4</td><td><input type="checkbox"/></td></tr> <tr><td><input type="checkbox"/></td><td>1</td><td>3</td><td><input type="checkbox"/></td></tr> <tr><td><input type="checkbox"/></td><td>-</td><td>-</td><td><input type="checkbox"/></td></tr> <tr><td><input type="checkbox"/></td><td>-</td><td>-</td><td><input type="checkbox"/></td></tr> <tr><td><input type="checkbox"/></td><td>-</td><td>-</td><td><input type="checkbox"/></td></tr> <tr><td><input type="checkbox"/></td><td>-</td><td>-</td><td><input type="checkbox"/></td></tr> <tr><td><input type="checkbox"/></td><td>-</td><td>-</td><td><input type="checkbox"/></td></tr> <tr><td><input type="checkbox"/></td><td>-</td><td>-</td><td><input type="checkbox"/></td></tr> </tbody> </table> | LEFT SIDE LIGHTS | 3 | 3 | RIGHT SIDE LIGHTS | <input type="checkbox"/> | 3 | 3 | <input type="checkbox"/> | <input type="checkbox"/> | 2 | 4 | <input type="checkbox"/> | <input type="checkbox"/> | 2 | 2 | <input type="checkbox"/> | <input type="checkbox"/> | 2 | 3 | <input type="checkbox"/> | <input type="checkbox"/> | 1 | 4 | <input type="checkbox"/> | <input type="checkbox"/> | 1 | 1 | <input type="checkbox"/> | <input type="checkbox"/> | 3 | 4 | <input type="checkbox"/> | <input type="checkbox"/> | 1 | 3 | <input type="checkbox"/> | <input type="checkbox"/> | - | - | <input type="checkbox"/> | <input type="checkbox"/> | - | - | <input type="checkbox"/> | <input type="checkbox"/> | - | - | <input type="checkbox"/> | <input type="checkbox"/> | - | - | <input type="checkbox"/> | <input type="checkbox"/> | - | - | <input type="checkbox"/> | <input type="checkbox"/> | - | - | <input type="checkbox"/> | <p>Four-choice answers, 16 questions, 48 points</p> <p style="text-align: center;">Code: 6474</p> <table style="width: 100%; border-collapse: collapse;"> <thead> <tr> <th style="text-align: left;">LEFT SIDE LIGHTS</th> <th style="text-align: center;">4</th> <th style="text-align: center;">4</th> <th style="text-align: right;">RIGHT SIDE LIGHTS</th> </tr> </thead> <tbody> <tr><td><input type="checkbox"/></td><td>4</td><td>4</td><td><input type="checkbox"/></td></tr> <tr><td><input type="checkbox"/></td><td>3</td><td>2</td><td><input type="checkbox"/></td></tr> <tr><td><input type="checkbox"/></td><td>2</td><td>4</td><td><input type="checkbox"/></td></tr> <tr><td><input type="checkbox"/></td><td>2</td><td>3</td><td><input type="checkbox"/></td></tr> <tr><td><input type="checkbox"/></td><td>1</td><td>1</td><td><input type="checkbox"/></td></tr> <tr><td><input type="checkbox"/></td><td>1</td><td>3</td><td><input type="checkbox"/></td></tr> <tr><td><input type="checkbox"/></td><td>1</td><td>3</td><td><input type="checkbox"/></td></tr> <tr><td><input type="checkbox"/></td><td>1</td><td>3</td><td><input type="checkbox"/></td></tr> <tr><td><input type="checkbox"/></td><td>-</td><td>-</td><td><input type="checkbox"/></td></tr> <tr><td><input type="checkbox"/></td><td>-</td><td>-</td><td><input type="checkbox"/></td></tr> <tr><td><input type="checkbox"/></td><td>-</td><td>-</td><td><input type="checkbox"/></td></tr> <tr><td><input type="checkbox"/></td><td>-</td><td>-</td><td><input type="checkbox"/></td></tr> <tr><td><input type="checkbox"/></td><td>-</td><td>-</td><td><input type="checkbox"/></td></tr> <tr><td><input type="checkbox"/></td><td>-</td><td>-</td><td><input type="checkbox"/></td></tr> </tbody> </table> | LEFT SIDE LIGHTS | 4 | 4 | RIGHT SIDE LIGHTS | <input type="checkbox"/> | 4 | 4 | <input type="checkbox"/> | <input type="checkbox"/> | 3 | 2 | <input type="checkbox"/> | <input type="checkbox"/> | 2 | 4 | <input type="checkbox"/> | <input type="checkbox"/> | 2 | 3 | <input type="checkbox"/> | <input type="checkbox"/> | 1 | 1 | <input type="checkbox"/> | <input type="checkbox"/> | 1 | 3 | <input type="checkbox"/> | <input type="checkbox"/> | 1 | 3 | <input type="checkbox"/> | <input type="checkbox"/> | 1 | 3 | <input type="checkbox"/> | <input type="checkbox"/> | - | - | <input type="checkbox"/> | <input type="checkbox"/> | - | - | <input type="checkbox"/> | <input type="checkbox"/> | - | - | <input type="checkbox"/> | <input type="checkbox"/> | - | - | <input type="checkbox"/> | <input type="checkbox"/> | - | - | <input type="checkbox"/> | <input type="checkbox"/> | - | - | <input type="checkbox"/> | | | | |
| LEFT SIDE LIGHTS | 2 | 3 | RIGHT SIDE LIGHTS | | | | | | | | | | | | | | | | | | | | | | | | | | | | | | | | | | | | | | | | | | | | | | | | | | | | | | | | | | | | | | | | | | | | | | | | | | | | | | | | | | | | | | | | | | | | | | | | | | | | | | | | | | | | | | | | | | | | | | | | | | | | | | | | | | | | | | | | | | | | | | | | | | | | | | | | | | | | | | | | | | | | | | | | | | | | | | | | | | | | | | | | | | | | | | | | | | | | | | | | | | | | | | | | | | | | | | | | | | | | | | | | | | | | | | | | | | | | |
| <input type="checkbox"/> | 2 | 3 | <input type="checkbox"/> | | | | | | | | | | | | | | | | | | | | | | | | | | | | | | | | | | | | | | | | | | | | | | | | | | | | | | | | | | | | | | | | | | | | | | | | | | | | | | | | | | | | | | | | | | | | | | | | | | | | | | | | | | | | | | | | | | | | | | | | | | | | | | | | | | | | | | | | | | | | | | | | | | | | | | | | | | | | | | | | | | | | | | | | | | | | | | | | | | | | | | | | | | | | | | | | | | | | | | | | | | | | | | | | | | | | | | | | | | | | | | | | | | | | | | | | | | | | |
| <input type="checkbox"/> | - | - | <input type="checkbox"/> | | | | | | | | | | | | | | | | | | | | | | | | | | | | | | | | | | | | | | | | | | | | | | | | | | | | | | | | | | | | | | | | | | | | | | | | | | | | | | | | | | | | | | | | | | | | | | | | | | | | | | | | | | | | | | | | | | | | | | | | | | | | | | | | | | | | | | | | | | | | | | | | | | | | | | | | | | | | | | | | | | | | | | | | | | | | | | | | | | | | | | | | | | | | | | | | | | | | | | | | | | | | | | | | | | | | | | | | | | | | | | | | | | | | | | | | | | | | |
| <input type="checkbox"/> | 2 | 4 | <input type="checkbox"/> | | | | | | | | | | | | | | | | | | | | | | | | | | | | | | | | | | | | | | | | | | | | | | | | | | | | | | | | | | | | | | | | | | | | | | | | | | | | | | | | | | | | | | | | | | | | | | | | | | | | | | | | | | | | | | | | | | | | | | | | | | | | | | | | | | | | | | | | | | | | | | | | | | | | | | | | | | | | | | | | | | | | | | | | | | | | | | | | | | | | | | | | | | | | | | | | | | | | | | | | | | | | | | | | | | | | | | | | | | | | | | | | | | | | | | | | | | | | |
| <input type="checkbox"/> | - | - | <input type="checkbox"/> | | | | | | | | | | | | | | | | | | | | | | | | | | | | | | | | | | | | | | | | | | | | | | | | | | | | | | | | | | | | | | | | | | | | | | | | | | | | | | | | | | | | | | | | | | | | | | | | | | | | | | | | | | | | | | | | | | | | | | | | | | | | | | | | | | | | | | | | | | | | | | | | | | | | | | | | | | | | | | | | | | | | | | | | | | | | | | | | | | | | | | | | | | | | | | | | | | | | | | | | | | | | | | | | | | | | | | | | | | | | | | | | | | | | | | | | | | | | |
| <input type="checkbox"/> | 4 | 2 | <input type="checkbox"/> | | | | | | | | | | | | | | | | | | | | | | | | | | | | | | | | | | | | | | | | | | | | | | | | | | | | | | | | | | | | | | | | | | | | | | | | | | | | | | | | | | | | | | | | | | | | | | | | | | | | | | | | | | | | | | | | | | | | | | | | | | | | | | | | | | | | | | | | | | | | | | | | | | | | | | | | | | | | | | | | | | | | | | | | | | | | | | | | | | | | | | | | | | | | | | | | | | | | | | | | | | | | | | | | | | | | | | | | | | | | | | | | | | | | | | | | | | | | |
| <input type="checkbox"/> | - | - | <input type="checkbox"/> | | | | | | | | | | | | | | | | | | | | | | | | | | | | | | | | | | | | | | | | | | | | | | | | | | | | | | | | | | | | | | | | | | | | | | | | | | | | | | | | | | | | | | | | | | | | | | | | | | | | | | | | | | | | | | | | | | | | | | | | | | | | | | | | | | | | | | | | | | | | | | | | | | | | | | | | | | | | | | | | | | | | | | | | | | | | | | | | | | | | | | | | | | | | | | | | | | | | | | | | | | | | | | | | | | | | | | | | | | | | | | | | | | | | | | | | | | | | |
| <input type="checkbox"/> | 3 | 3 | <input type="checkbox"/> | | | | | | | | | | | | | | | | | | | | | | | | | | | | | | | | | | | | | | | | | | | | | | | | | | | | | | | | | | | | | | | | | | | | | | | | | | | | | | | | | | | | | | | | | | | | | | | | | | | | | | | | | | | | | | | | | | | | | | | | | | | | | | | | | | | | | | | | | | | | | | | | | | | | | | | | | | | | | | | | | | | | | | | | | | | | | | | | | | | | | | | | | | | | | | | | | | | | | | | | | | | | | | | | | | | | | | | | | | | | | | | | | | | | | | | | | | | | |
| <input type="checkbox"/> | - | - | <input type="checkbox"/> | | | | | | | | | | | | | | | | | | | | | | | | | | | | | | | | | | | | | | | | | | | | | | | | | | | | | | | | | | | | | | | | | | | | | | | | | | | | | | | | | | | | | | | | | | | | | | | | | | | | | | | | | | | | | | | | | | | | | | | | | | | | | | | | | | | | | | | | | | | | | | | | | | | | | | | | | | | | | | | | | | | | | | | | | | | | | | | | | | | | | | | | | | | | | | | | | | | | | | | | | | | | | | | | | | | | | | | | | | | | | | | | | | | | | | | | | | | | |
| <input type="checkbox"/> | 1 | 2 | <input type="checkbox"/> | | | | | | | | | | | | | | | | | | | | | | | | | | | | | | | | | | | | | | | | | | | | | | | | | | | | | | | | | | | | | | | | | | | | | | | | | | | | | | | | | | | | | | | | | | | | | | | | | | | | | | | | | | | | | | | | | | | | | | | | | | | | | | | | | | | | | | | | | | | | | | | | | | | | | | | | | | | | | | | | | | | | | | | | | | | | | | | | | | | | | | | | | | | | | | | | | | | | | | | | | | | | | | | | | | | | | | | | | | | | | | | | | | | | | | | | | | | | |
| <input type="checkbox"/> | - | - | <input type="checkbox"/> | | | | | | | | | | | | | | | | | | | | | | | | | | | | | | | | | | | | | | | | | | | | | | | | | | | | | | | | | | | | | | | | | | | | | | | | | | | | | | | | | | | | | | | | | | | | | | | | | | | | | | | | | | | | | | | | | | | | | | | | | | | | | | | | | | | | | | | | | | | | | | | | | | | | | | | | | | | | | | | | | | | | | | | | | | | | | | | | | | | | | | | | | | | | | | | | | | | | | | | | | | | | | | | | | | | | | | | | | | | | | | | | | | | | | | | | | | | | |
| <input type="checkbox"/> | 4 | 1 | <input type="checkbox"/> | | | | | | | | | | | | | | | | | | | | | | | | | | | | | | | | | | | | | | | | | | | | | | | | | | | | | | | | | | | | | | | | | | | | | | | | | | | | | | | | | | | | | | | | | | | | | | | | | | | | | | | | | | | | | | | | | | | | | | | | | | | | | | | | | | | | | | | | | | | | | | | | | | | | | | | | | | | | | | | | | | | | | | | | | | | | | | | | | | | | | | | | | | | | | | | | | | | | | | | | | | | | | | | | | | | | | | | | | | | | | | | | | | | | | | | | | | | | |
| <input type="checkbox"/> | - | - | <input type="checkbox"/> | | | | | | | | | | | | | | | | | | | | | | | | | | | | | | | | | | | | | | | | | | | | | | | | | | | | | | | | | | | | | | | | | | | | | | | | | | | | | | | | | | | | | | | | | | | | | | | | | | | | | | | | | | | | | | | | | | | | | | | | | | | | | | | | | | | | | | | | | | | | | | | | | | | | | | | | | | | | | | | | | | | | | | | | | | | | | | | | | | | | | | | | | | | | | | | | | | | | | | | | | | | | | | | | | | | | | | | | | | | | | | | | | | | | | | | | | | | | |
| <input type="checkbox"/> | 1 | 4 | <input type="checkbox"/> | | | | | | | | | | | | | | | | | | | | | | | | | | | | | | | | | | | | | | | | | | | | | | | | | | | | | | | | | | | | | | | | | | | | | | | | | | | | | | | | | | | | | | | | | | | | | | | | | | | | | | | | | | | | | | | | | | | | | | | | | | | | | | | | | | | | | | | | | | | | | | | | | | | | | | | | | | | | | | | | | | | | | | | | | | | | | | | | | | | | | | | | | | | | | | | | | | | | | | | | | | | | | | | | | | | | | | | | | | | | | | | | | | | | | | | | | | | | |
| LEFT SIDE LIGHTS | 1 | 4 | RIGHT SIDE LIGHTS | | | | | | | | | | | | | | | | | | | | | | | | | | | | | | | | | | | | | | | | | | | | | | | | | | | | | | | | | | | | | | | | | | | | | | | | | | | | | | | | | | | | | | | | | | | | | | | | | | | | | | | | | | | | | | | | | | | | | | | | | | | | | | | | | | | | | | | | | | | | | | | | | | | | | | | | | | | | | | | | | | | | | | | | | | | | | | | | | | | | | | | | | | | | | | | | | | | | | | | | | | | | | | | | | | | | | | | | | | | | | | | | | | | | | | | | | | | | |
| <input type="checkbox"/> | 1 | 4 | <input type="checkbox"/> | | | | | | | | | | | | | | | | | | | | | | | | | | | | | | | | | | | | | | | | | | | | | | | | | | | | | | | | | | | | | | | | | | | | | | | | | | | | | | | | | | | | | | | | | | | | | | | | | | | | | | | | | | | | | | | | | | | | | | | | | | | | | | | | | | | | | | | | | | | | | | | | | | | | | | | | | | | | | | | | | | | | | | | | | | | | | | | | | | | | | | | | | | | | | | | | | | | | | | | | | | | | | | | | | | | | | | | | | | | | | | | | | | | | | | | | | | | | |
| <input type="checkbox"/> | - | - | <input type="checkbox"/> | | | | | | | | | | | | | | | | | | | | | | | | | | | | | | | | | | | | | | | | | | | | | | | | | | | | | | | | | | | | | | | | | | | | | | | | | | | | | | | | | | | | | | | | | | | | | | | | | | | | | | | | | | | | | | | | | | | | | | | | | | | | | | | | | | | | | | | | | | | | | | | | | | | | | | | | | | | | | | | | | | | | | | | | | | | | | | | | | | | | | | | | | | | | | | | | | | | | | | | | | | | | | | | | | | | | | | | | | | | | | | | | | | | | | | | | | | | | |
| <input type="checkbox"/> | 2 | 2 | <input type="checkbox"/> | | | | | | | | | | | | | | | | | | | | | | | | | | | | | | | | | | | | | | | | | | | | | | | | | | | | | | | | | | | | | | | | | | | | | | | | | | | | | | | | | | | | | | | | | | | | | | | | | | | | | | | | | | | | | | | | | | | | | | | | | | | | | | | | | | | | | | | | | | | | | | | | | | | | | | | | | | | | | | | | | | | | | | | | | | | | | | | | | | | | | | | | | | | | | | | | | | | | | | | | | | | | | | | | | | | | | | | | | | | | | | | | | | | | | | | | | | | | |
| <input type="checkbox"/> | - | - | <input type="checkbox"/> | | | | | | | | | | | | | | | | | | | | | | | | | | | | | | | | | | | | | | | | | | | | | | | | | | | | | | | | | | | | | | | | | | | | | | | | | | | | | | | | | | | | | | | | | | | | | | | | | | | | | | | | | | | | | | | | | | | | | | | | | | | | | | | | | | | | | | | | | | | | | | | | | | | | | | | | | | | | | | | | | | | | | | | | | | | | | | | | | | | | | | | | | | | | | | | | | | | | | | | | | | | | | | | | | | | | | | | | | | | | | | | | | | | | | | | | | | | | |
| <input type="checkbox"/> | 3 | 4 | <input type="checkbox"/> | | | | | | | | | | | | | | | | | | | | | | | | | | | | | | | | | | | | | | | | | | | | | | | | | | | | | | | | | | | | | | | | | | | | | | | | | | | | | | | | | | | | | | | | | | | | | | | | | | | | | | | | | | | | | | | | | | | | | | | | | | | | | | | | | | | | | | | | | | | | | | | | | | | | | | | | | | | | | | | | | | | | | | | | | | | | | | | | | | | | | | | | | | | | | | | | | | | | | | | | | | | | | | | | | | | | | | | | | | | | | | | | | | | | | | | | | | | | |
| <input type="checkbox"/> | - | - | <input type="checkbox"/> | | | | | | | | | | | | | | | | | | | | | | | | | | | | | | | | | | | | | | | | | | | | | | | | | | | | | | | | | | | | | | | | | | | | | | | | | | | | | | | | | | | | | | | | | | | | | | | | | | | | | | | | | | | | | | | | | | | | | | | | | | | | | | | | | | | | | | | | | | | | | | | | | | | | | | | | | | | | | | | | | | | | | | | | | | | | | | | | | | | | | | | | | | | | | | | | | | | | | | | | | | | | | | | | | | | | | | | | | | | | | | | | | | | | | | | | | | | | |
| <input type="checkbox"/> | 1 | 4 | <input type="checkbox"/> | | | | | | | | | | | | | | | | | | | | | | | | | | | | | | | | | | | | | | | | | | | | | | | | | | | | | | | | | | | | | | | | | | | | | | | | | | | | | | | | | | | | | | | | | | | | | | | | | | | | | | | | | | | | | | | | | | | | | | | | | | | | | | | | | | | | | | | | | | | | | | | | | | | | | | | | | | | | | | | | | | | | | | | | | | | | | | | | | | | | | | | | | | | | | | | | | | | | | | | | | | | | | | | | | | | | | | | | | | | | | | | | | | | | | | | | | | | | |
| <input type="checkbox"/> | - | - | <input type="checkbox"/> | | | | | | | | | | | | | | | | | | | | | | | | | | | | | | | | | | | | | | | | | | | | | | | | | | | | | | | | | | | | | | | | | | | | | | | | | | | | | | | | | | | | | | | | | | | | | | | | | | | | | | | | | | | | | | | | | | | | | | | | | | | | | | | | | | | | | | | | | | | | | | | | | | | | | | | | | | | | | | | | | | | | | | | | | | | | | | | | | | | | | | | | | | | | | | | | | | | | | | | | | | | | | | | | | | | | | | | | | | | | | | | | | | | | | | | | | | | | |
| <input type="checkbox"/> | 1 | 2 | <input type="checkbox"/> | | | | | | | | | | | | | | | | | | | | | | | | | | | | | | | | | | | | | | | | | | | | | | | | | | | | | | | | | | | | | | | | | | | | | | | | | | | | | | | | | | | | | | | | | | | | | | | | | | | | | | | | | | | | | | | | | | | | | | | | | | | | | | | | | | | | | | | | | | | | | | | | | | | | | | | | | | | | | | | | | | | | | | | | | | | | | | | | | | | | | | | | | | | | | | | | | | | | | | | | | | | | | | | | | | | | | | | | | | | | | | | | | | | | | | | | | | | | |
| <input type="checkbox"/> | - | - | <input type="checkbox"/> | | | | | | | | | | | | | | | | | | | | | | | | | | | | | | | | | | | | | | | | | | | | | | | | | | | | | | | | | | | | | | | | | | | | | | | | | | | | | | | | | | | | | | | | | | | | | | | | | | | | | | | | | | | | | | | | | | | | | | | | | | | | | | | | | | | | | | | | | | | | | | | | | | | | | | | | | | | | | | | | | | | | | | | | | | | | | | | | | | | | | | | | | | | | | | | | | | | | | | | | | | | | | | | | | | | | | | | | | | | | | | | | | | | | | | | | | | | | |
| <input type="checkbox"/> | 1 | 3 | <input type="checkbox"/> | | | | | | | | | | | | | | | | | | | | | | | | | | | | | | | | | | | | | | | | | | | | | | | | | | | | | | | | | | | | | | | | | | | | | | | | | | | | | | | | | | | | | | | | | | | | | | | | | | | | | | | | | | | | | | | | | | | | | | | | | | | | | | | | | | | | | | | | | | | | | | | | | | | | | | | | | | | | | | | | | | | | | | | | | | | | | | | | | | | | | | | | | | | | | | | | | | | | | | | | | | | | | | | | | | | | | | | | | | | | | | | | | | | | | | | | | | | | |
| <input type="checkbox"/> | - | - | <input type="checkbox"/> | | | | | | | | | | | | | | | | | | | | | | | | | | | | | | | | | | | | | | | | | | | | | | | | | | | | | | | | | | | | | | | | | | | | | | | | | | | | | | | | | | | | | | | | | | | | | | | | | | | | | | | | | | | | | | | | | | | | | | | | | | | | | | | | | | | | | | | | | | | | | | | | | | | | | | | | | | | | | | | | | | | | | | | | | | | | | | | | | | | | | | | | | | | | | | | | | | | | | | | | | | | | | | | | | | | | | | | | | | | | | | | | | | | | | | | | | | | | |
| <input type="checkbox"/> | 3 | 4 | <input type="checkbox"/> | | | | | | | | | | | | | | | | | | | | | | | | | | | | | | | | | | | | | | | | | | | | | | | | | | | | | | | | | | | | | | | | | | | | | | | | | | | | | | | | | | | | | | | | | | | | | | | | | | | | | | | | | | | | | | | | | | | | | | | | | | | | | | | | | | | | | | | | | | | | | | | | | | | | | | | | | | | | | | | | | | | | | | | | | | | | | | | | | | | | | | | | | | | | | | | | | | | | | | | | | | | | | | | | | | | | | | | | | | | | | | | | | | | | | | | | | | | | |
| LEFT SIDE LIGHTS | 3 | 3 | RIGHT SIDE LIGHTS | | | | | | | | | | | | | | | | | | | | | | | | | | | | | | | | | | | | | | | | | | | | | | | | | | | | | | | | | | | | | | | | | | | | | | | | | | | | | | | | | | | | | | | | | | | | | | | | | | | | | | | | | | | | | | | | | | | | | | | | | | | | | | | | | | | | | | | | | | | | | | | | | | | | | | | | | | | | | | | | | | | | | | | | | | | | | | | | | | | | | | | | | | | | | | | | | | | | | | | | | | | | | | | | | | | | | | | | | | | | | | | | | | | | | | | | | | | | |
| <input type="checkbox"/> | 3 | 3 | <input type="checkbox"/> | | | | | | | | | | | | | | | | | | | | | | | | | | | | | | | | | | | | | | | | | | | | | | | | | | | | | | | | | | | | | | | | | | | | | | | | | | | | | | | | | | | | | | | | | | | | | | | | | | | | | | | | | | | | | | | | | | | | | | | | | | | | | | | | | | | | | | | | | | | | | | | | | | | | | | | | | | | | | | | | | | | | | | | | | | | | | | | | | | | | | | | | | | | | | | | | | | | | | | | | | | | | | | | | | | | | | | | | | | | | | | | | | | | | | | | | | | | | |
| <input type="checkbox"/> | 2 | 4 | <input type="checkbox"/> | | | | | | | | | | | | | | | | | | | | | | | | | | | | | | | | | | | | | | | | | | | | | | | | | | | | | | | | | | | | | | | | | | | | | | | | | | | | | | | | | | | | | | | | | | | | | | | | | | | | | | | | | | | | | | | | | | | | | | | | | | | | | | | | | | | | | | | | | | | | | | | | | | | | | | | | | | | | | | | | | | | | | | | | | | | | | | | | | | | | | | | | | | | | | | | | | | | | | | | | | | | | | | | | | | | | | | | | | | | | | | | | | | | | | | | | | | | | |
| <input type="checkbox"/> | 2 | 2 | <input type="checkbox"/> | | | | | | | | | | | | | | | | | | | | | | | | | | | | | | | | | | | | | | | | | | | | | | | | | | | | | | | | | | | | | | | | | | | | | | | | | | | | | | | | | | | | | | | | | | | | | | | | | | | | | | | | | | | | | | | | | | | | | | | | | | | | | | | | | | | | | | | | | | | | | | | | | | | | | | | | | | | | | | | | | | | | | | | | | | | | | | | | | | | | | | | | | | | | | | | | | | | | | | | | | | | | | | | | | | | | | | | | | | | | | | | | | | | | | | | | | | | | |
| <input type="checkbox"/> | 2 | 3 | <input type="checkbox"/> | | | | | | | | | | | | | | | | | | | | | | | | | | | | | | | | | | | | | | | | | | | | | | | | | | | | | | | | | | | | | | | | | | | | | | | | | | | | | | | | | | | | | | | | | | | | | | | | | | | | | | | | | | | | | | | | | | | | | | | | | | | | | | | | | | | | | | | | | | | | | | | | | | | | | | | | | | | | | | | | | | | | | | | | | | | | | | | | | | | | | | | | | | | | | | | | | | | | | | | | | | | | | | | | | | | | | | | | | | | | | | | | | | | | | | | | | | | | |
| <input type="checkbox"/> | 1 | 4 | <input type="checkbox"/> | | | | | | | | | | | | | | | | | | | | | | | | | | | | | | | | | | | | | | | | | | | | | | | | | | | | | | | | | | | | | | | | | | | | | | | | | | | | | | | | | | | | | | | | | | | | | | | | | | | | | | | | | | | | | | | | | | | | | | | | | | | | | | | | | | | | | | | | | | | | | | | | | | | | | | | | | | | | | | | | | | | | | | | | | | | | | | | | | | | | | | | | | | | | | | | | | | | | | | | | | | | | | | | | | | | | | | | | | | | | | | | | | | | | | | | | | | | | |
| <input type="checkbox"/> | 1 | 1 | <input type="checkbox"/> | | | | | | | | | | | | | | | | | | | | | | | | | | | | | | | | | | | | | | | | | | | | | | | | | | | | | | | | | | | | | | | | | | | | | | | | | | | | | | | | | | | | | | | | | | | | | | | | | | | | | | | | | | | | | | | | | | | | | | | | | | | | | | | | | | | | | | | | | | | | | | | | | | | | | | | | | | | | | | | | | | | | | | | | | | | | | | | | | | | | | | | | | | | | | | | | | | | | | | | | | | | | | | | | | | | | | | | | | | | | | | | | | | | | | | | | | | | | |
| <input type="checkbox"/> | 3 | 4 | <input type="checkbox"/> | | | | | | | | | | | | | | | | | | | | | | | | | | | | | | | | | | | | | | | | | | | | | | | | | | | | | | | | | | | | | | | | | | | | | | | | | | | | | | | | | | | | | | | | | | | | | | | | | | | | | | | | | | | | | | | | | | | | | | | | | | | | | | | | | | | | | | | | | | | | | | | | | | | | | | | | | | | | | | | | | | | | | | | | | | | | | | | | | | | | | | | | | | | | | | | | | | | | | | | | | | | | | | | | | | | | | | | | | | | | | | | | | | | | | | | | | | | | |
| <input type="checkbox"/> | 1 | 3 | <input type="checkbox"/> | | | | | | | | | | | | | | | | | | | | | | | | | | | | | | | | | | | | | | | | | | | | | | | | | | | | | | | | | | | | | | | | | | | | | | | | | | | | | | | | | | | | | | | | | | | | | | | | | | | | | | | | | | | | | | | | | | | | | | | | | | | | | | | | | | | | | | | | | | | | | | | | | | | | | | | | | | | | | | | | | | | | | | | | | | | | | | | | | | | | | | | | | | | | | | | | | | | | | | | | | | | | | | | | | | | | | | | | | | | | | | | | | | | | | | | | | | | | |
| <input type="checkbox"/> | - | - | <input type="checkbox"/> | | | | | | | | | | | | | | | | | | | | | | | | | | | | | | | | | | | | | | | | | | | | | | | | | | | | | | | | | | | | | | | | | | | | | | | | | | | | | | | | | | | | | | | | | | | | | | | | | | | | | | | | | | | | | | | | | | | | | | | | | | | | | | | | | | | | | | | | | | | | | | | | | | | | | | | | | | | | | | | | | | | | | | | | | | | | | | | | | | | | | | | | | | | | | | | | | | | | | | | | | | | | | | | | | | | | | | | | | | | | | | | | | | | | | | | | | | | | |
| <input type="checkbox"/> | - | - | <input type="checkbox"/> | | | | | | | | | | | | | | | | | | | | | | | | | | | | | | | | | | | | | | | | | | | | | | | | | | | | | | | | | | | | | | | | | | | | | | | | | | | | | | | | | | | | | | | | | | | | | | | | | | | | | | | | | | | | | | | | | | | | | | | | | | | | | | | | | | | | | | | | | | | | | | | | | | | | | | | | | | | | | | | | | | | | | | | | | | | | | | | | | | | | | | | | | | | | | | | | | | | | | | | | | | | | | | | | | | | | | | | | | | | | | | | | | | | | | | | | | | | | |
| <input type="checkbox"/> | - | - | <input type="checkbox"/> | | | | | | | | | | | | | | | | | | | | | | | | | | | | | | | | | | | | | | | | | | | | | | | | | | | | | | | | | | | | | | | | | | | | | | | | | | | | | | | | | | | | | | | | | | | | | | | | | | | | | | | | | | | | | | | | | | | | | | | | | | | | | | | | | | | | | | | | | | | | | | | | | | | | | | | | | | | | | | | | | | | | | | | | | | | | | | | | | | | | | | | | | | | | | | | | | | | | | | | | | | | | | | | | | | | | | | | | | | | | | | | | | | | | | | | | | | | | |
| <input type="checkbox"/> | - | - | <input type="checkbox"/> | | | | | | | | | | | | | | | | | | | | | | | | | | | | | | | | | | | | | | | | | | | | | | | | | | | | | | | | | | | | | | | | | | | | | | | | | | | | | | | | | | | | | | | | | | | | | | | | | | | | | | | | | | | | | | | | | | | | | | | | | | | | | | | | | | | | | | | | | | | | | | | | | | | | | | | | | | | | | | | | | | | | | | | | | | | | | | | | | | | | | | | | | | | | | | | | | | | | | | | | | | | | | | | | | | | | | | | | | | | | | | | | | | | | | | | | | | | | |
| <input type="checkbox"/> | - | - | <input type="checkbox"/> | | | | | | | | | | | | | | | | | | | | | | | | | | | | | | | | | | | | | | | | | | | | | | | | | | | | | | | | | | | | | | | | | | | | | | | | | | | | | | | | | | | | | | | | | | | | | | | | | | | | | | | | | | | | | | | | | | | | | | | | | | | | | | | | | | | | | | | | | | | | | | | | | | | | | | | | | | | | | | | | | | | | | | | | | | | | | | | | | | | | | | | | | | | | | | | | | | | | | | | | | | | | | | | | | | | | | | | | | | | | | | | | | | | | | | | | | | | | |
| <input type="checkbox"/> | - | - | <input type="checkbox"/> | | | | | | | | | | | | | | | | | | | | | | | | | | | | | | | | | | | | | | | | | | | | | | | | | | | | | | | | | | | | | | | | | | | | | | | | | | | | | | | | | | | | | | | | | | | | | | | | | | | | | | | | | | | | | | | | | | | | | | | | | | | | | | | | | | | | | | | | | | | | | | | | | | | | | | | | | | | | | | | | | | | | | | | | | | | | | | | | | | | | | | | | | | | | | | | | | | | | | | | | | | | | | | | | | | | | | | | | | | | | | | | | | | | | | | | | | | | | |
| LEFT SIDE LIGHTS | 4 | 4 | RIGHT SIDE LIGHTS | | | | | | | | | | | | | | | | | | | | | | | | | | | | | | | | | | | | | | | | | | | | | | | | | | | | | | | | | | | | | | | | | | | | | | | | | | | | | | | | | | | | | | | | | | | | | | | | | | | | | | | | | | | | | | | | | | | | | | | | | | | | | | | | | | | | | | | | | | | | | | | | | | | | | | | | | | | | | | | | | | | | | | | | | | | | | | | | | | | | | | | | | | | | | | | | | | | | | | | | | | | | | | | | | | | | | | | | | | | | | | | | | | | | | | | | | | | | |
| <input type="checkbox"/> | 4 | 4 | <input type="checkbox"/> | | | | | | | | | | | | | | | | | | | | | | | | | | | | | | | | | | | | | | | | | | | | | | | | | | | | | | | | | | | | | | | | | | | | | | | | | | | | | | | | | | | | | | | | | | | | | | | | | | | | | | | | | | | | | | | | | | | | | | | | | | | | | | | | | | | | | | | | | | | | | | | | | | | | | | | | | | | | | | | | | | | | | | | | | | | | | | | | | | | | | | | | | | | | | | | | | | | | | | | | | | | | | | | | | | | | | | | | | | | | | | | | | | | | | | | | | | | | |
| <input type="checkbox"/> | 3 | 2 | <input type="checkbox"/> | | | | | | | | | | | | | | | | | | | | | | | | | | | | | | | | | | | | | | | | | | | | | | | | | | | | | | | | | | | | | | | | | | | | | | | | | | | | | | | | | | | | | | | | | | | | | | | | | | | | | | | | | | | | | | | | | | | | | | | | | | | | | | | | | | | | | | | | | | | | | | | | | | | | | | | | | | | | | | | | | | | | | | | | | | | | | | | | | | | | | | | | | | | | | | | | | | | | | | | | | | | | | | | | | | | | | | | | | | | | | | | | | | | | | | | | | | | | |
| <input type="checkbox"/> | 2 | 4 | <input type="checkbox"/> | | | | | | | | | | | | | | | | | | | | | | | | | | | | | | | | | | | | | | | | | | | | | | | | | | | | | | | | | | | | | | | | | | | | | | | | | | | | | | | | | | | | | | | | | | | | | | | | | | | | | | | | | | | | | | | | | | | | | | | | | | | | | | | | | | | | | | | | | | | | | | | | | | | | | | | | | | | | | | | | | | | | | | | | | | | | | | | | | | | | | | | | | | | | | | | | | | | | | | | | | | | | | | | | | | | | | | | | | | | | | | | | | | | | | | | | | | | | |
| <input type="checkbox"/> | 2 | 3 | <input type="checkbox"/> | | | | | | | | | | | | | | | | | | | | | | | | | | | | | | | | | | | | | | | | | | | | | | | | | | | | | | | | | | | | | | | | | | | | | | | | | | | | | | | | | | | | | | | | | | | | | | | | | | | | | | | | | | | | | | | | | | | | | | | | | | | | | | | | | | | | | | | | | | | | | | | | | | | | | | | | | | | | | | | | | | | | | | | | | | | | | | | | | | | | | | | | | | | | | | | | | | | | | | | | | | | | | | | | | | | | | | | | | | | | | | | | | | | | | | | | | | | | |
| <input type="checkbox"/> | 1 | 1 | <input type="checkbox"/> | | | | | | | | | | | | | | | | | | | | | | | | | | | | | | | | | | | | | | | | | | | | | | | | | | | | | | | | | | | | | | | | | | | | | | | | | | | | | | | | | | | | | | | | | | | | | | | | | | | | | | | | | | | | | | | | | | | | | | | | | | | | | | | | | | | | | | | | | | | | | | | | | | | | | | | | | | | | | | | | | | | | | | | | | | | | | | | | | | | | | | | | | | | | | | | | | | | | | | | | | | | | | | | | | | | | | | | | | | | | | | | | | | | | | | | | | | | | |
| <input type="checkbox"/> | 1 | 3 | <input type="checkbox"/> | | | | | | | | | | | | | | | | | | | | | | | | | | | | | | | | | | | | | | | | | | | | | | | | | | | | | | | | | | | | | | | | | | | | | | | | | | | | | | | | | | | | | | | | | | | | | | | | | | | | | | | | | | | | | | | | | | | | | | | | | | | | | | | | | | | | | | | | | | | | | | | | | | | | | | | | | | | | | | | | | | | | | | | | | | | | | | | | | | | | | | | | | | | | | | | | | | | | | | | | | | | | | | | | | | | | | | | | | | | | | | | | | | | | | | | | | | | | |
| <input type="checkbox"/> | 1 | 3 | <input type="checkbox"/> | | | | | | | | | | | | | | | | | | | | | | | | | | | | | | | | | | | | | | | | | | | | | | | | | | | | | | | | | | | | | | | | | | | | | | | | | | | | | | | | | | | | | | | | | | | | | | | | | | | | | | | | | | | | | | | | | | | | | | | | | | | | | | | | | | | | | | | | | | | | | | | | | | | | | | | | | | | | | | | | | | | | | | | | | | | | | | | | | | | | | | | | | | | | | | | | | | | | | | | | | | | | | | | | | | | | | | | | | | | | | | | | | | | | | | | | | | | | |
| <input type="checkbox"/> | 1 | 3 | <input type="checkbox"/> | | | | | | | | | | | | | | | | | | | | | | | | | | | | | | | | | | | | | | | | | | | | | | | | | | | | | | | | | | | | | | | | | | | | | | | | | | | | | | | | | | | | | | | | | | | | | | | | | | | | | | | | | | | | | | | | | | | | | | | | | | | | | | | | | | | | | | | | | | | | | | | | | | | | | | | | | | | | | | | | | | | | | | | | | | | | | | | | | | | | | | | | | | | | | | | | | | | | | | | | | | | | | | | | | | | | | | | | | | | | | | | | | | | | | | | | | | | | |
| <input type="checkbox"/> | - | - | <input type="checkbox"/> | | | | | | | | | | | | | | | | | | | | | | | | | | | | | | | | | | | | | | | | | | | | | | | | | | | | | | | | | | | | | | | | | | | | | | | | | | | | | | | | | | | | | | | | | | | | | | | | | | | | | | | | | | | | | | | | | | | | | | | | | | | | | | | | | | | | | | | | | | | | | | | | | | | | | | | | | | | | | | | | | | | | | | | | | | | | | | | | | | | | | | | | | | | | | | | | | | | | | | | | | | | | | | | | | | | | | | | | | | | | | | | | | | | | | | | | | | | | |
| <input type="checkbox"/> | - | - | <input type="checkbox"/> | | | | | | | | | | | | | | | | | | | | | | | | | | | | | | | | | | | | | | | | | | | | | | | | | | | | | | | | | | | | | | | | | | | | | | | | | | | | | | | | | | | | | | | | | | | | | | | | | | | | | | | | | | | | | | | | | | | | | | | | | | | | | | | | | | | | | | | | | | | | | | | | | | | | | | | | | | | | | | | | | | | | | | | | | | | | | | | | | | | | | | | | | | | | | | | | | | | | | | | | | | | | | | | | | | | | | | | | | | | | | | | | | | | | | | | | | | | | |
| <input type="checkbox"/> | - | - | <input type="checkbox"/> | | | | | | | | | | | | | | | | | | | | | | | | | | | | | | | | | | | | | | | | | | | | | | | | | | | | | | | | | | | | | | | | | | | | | | | | | | | | | | | | | | | | | | | | | | | | | | | | | | | | | | | | | | | | | | | | | | | | | | | | | | | | | | | | | | | | | | | | | | | | | | | | | | | | | | | | | | | | | | | | | | | | | | | | | | | | | | | | | | | | | | | | | | | | | | | | | | | | | | | | | | | | | | | | | | | | | | | | | | | | | | | | | | | | | | | | | | | | |
| <input type="checkbox"/> | - | - | <input type="checkbox"/> | | | | | | | | | | | | | | | | | | | | | | | | | | | | | | | | | | | | | | | | | | | | | | | | | | | | | | | | | | | | | | | | | | | | | | | | | | | | | | | | | | | | | | | | | | | | | | | | | | | | | | | | | | | | | | | | | | | | | | | | | | | | | | | | | | | | | | | | | | | | | | | | | | | | | | | | | | | | | | | | | | | | | | | | | | | | | | | | | | | | | | | | | | | | | | | | | | | | | | | | | | | | | | | | | | | | | | | | | | | | | | | | | | | | | | | | | | | | |
| <input type="checkbox"/> | - | - | <input type="checkbox"/> | | | | | | | | | | | | | | | | | | | | | | | | | | | | | | | | | | | | | | | | | | | | | | | | | | | | | | | | | | | | | | | | | | | | | | | | | | | | | | | | | | | | | | | | | | | | | | | | | | | | | | | | | | | | | | | | | | | | | | | | | | | | | | | | | | | | | | | | | | | | | | | | | | | | | | | | | | | | | | | | | | | | | | | | | | | | | | | | | | | | | | | | | | | | | | | | | | | | | | | | | | | | | | | | | | | | | | | | | | | | | | | | | | | | | | | | | | | | |
| <input type="checkbox"/> | - | - | <input type="checkbox"/> | | | | | | | | | | | | | | | | | | | | | | | | | | | | | | | | | | | | | | | | | | | | | | | | | | | | | | | | | | | | | | | | | | | | | | | | | | | | | | | | | | | | | | | | | | | | | | | | | | | | | | | | | | | | | | | | | | | | | | | | | | | | | | | | | | | | | | | | | | | | | | | | | | | | | | | | | | | | | | | | | | | | | | | | | | | | | | | | | | | | | | | | | | | | | | | | | | | | | | | | | | | | | | | | | | | | | | | | | | | | | | | | | | | | | | | | | | | | |
| <p>Four-choice answers, 20 questions, 60 points</p> <p style="text-align: center;">Code: 7503</p> <table style="width: 100%; border-collapse: collapse;"> <thead> <tr> <th style="text-align: left;">LEFT SIDE LIGHTS</th> <th style="text-align: center;">2</th> <th style="text-align: center;">1</th> <th style="text-align: right;">RIGHT SIDE LIGHTS</th> </tr> </thead> <tbody> <tr><td><input type="checkbox"/></td><td>2</td><td>1</td><td><input type="checkbox"/></td></tr> <tr><td><input type="checkbox"/></td><td>3</td><td>4</td><td><input type="checkbox"/></td></tr> <tr><td><input type="checkbox"/></td><td>1</td><td>1</td><td><input type="checkbox"/></td></tr> <tr><td><input type="checkbox"/></td><td>4</td><td>2</td><td><input type="checkbox"/></td></tr> <tr><td><input type="checkbox"/></td><td>3</td><td>1</td><td><input type="checkbox"/></td></tr> <tr><td><input type="checkbox"/></td><td>4</td><td>1</td><td><input type="checkbox"/></td></tr> <tr><td><input type="checkbox"/></td><td>3</td><td>3</td><td><input type="checkbox"/></td></tr> <tr><td><input type="checkbox"/></td><td>2</td><td>3</td><td><input type="checkbox"/></td></tr> <tr><td><input type="checkbox"/></td><td>4</td><td>3</td><td><input type="checkbox"/></td></tr> <tr><td><input type="checkbox"/></td><td>2</td><td>4</td><td><input type="checkbox"/></td></tr> <tr><td><input type="checkbox"/></td><td>-</td><td>-</td><td><input type="checkbox"/></td></tr> <tr><td><input type="checkbox"/></td><td>-</td><td>-</td><td><input type="checkbox"/></td></tr> <tr><td><input type="checkbox"/></td><td>-</td><td>-</td><td><input type="checkbox"/></td></tr> </tbody> </table> | LEFT SIDE LIGHTS | 2 | 1 | RIGHT SIDE LIGHTS | <input type="checkbox"/> | 2 | 1 | <input type="checkbox"/> | <input type="checkbox"/> | 3 | 4 | <input type="checkbox"/> | <input type="checkbox"/> | 1 | 1 | <input type="checkbox"/> | <input type="checkbox"/> | 4 | 2 | <input type="checkbox"/> | <input type="checkbox"/> | 3 | 1 | <input type="checkbox"/> | <input type="checkbox"/> | 4 | 1 | <input type="checkbox"/> | <input type="checkbox"/> | 3 | 3 | <input type="checkbox"/> | <input type="checkbox"/> | 2 | 3 | <input type="checkbox"/> | <input type="checkbox"/> | 4 | 3 | <input type="checkbox"/> | <input type="checkbox"/> | 2 | 4 | <input type="checkbox"/> | <input type="checkbox"/> | - | - | <input type="checkbox"/> | <input type="checkbox"/> | - | - | <input type="checkbox"/> | <input type="checkbox"/> | - | - | <input type="checkbox"/> | <p>Four-choice answers, 20 questions, 60 points</p> <p style="text-align: center;">Code: 7982</p> <table style="width: 100%; border-collapse: collapse;"> <thead> <tr> <th style="text-align: left;">LEFT SIDE LIGHTS</th> <th style="text-align: center;">2</th> <th style="text-align: center;">2</th> <th style="text-align: right;">RIGHT SIDE LIGHTS</th> </tr> </thead> <tbody> <tr><td><input type="checkbox"/></td><td>2</td><td>2</td><td><input type="checkbox"/></td></tr> <tr><td><input type="checkbox"/></td><td>4</td><td>4</td><td><input type="checkbox"/></td></tr> <tr><td><input type="checkbox"/></td><td>3</td><td>3</td><td><input type="checkbox"/></td></tr> <tr><td><input type="checkbox"/></td><td>1</td><td>2</td><td><input type="checkbox"/></td></tr> <tr><td><input type="checkbox"/></td><td>2</td><td>4</td><td><input type="checkbox"/></td></tr> <tr><td><input type="checkbox"/></td><td>1</td><td>3</td><td><input type="checkbox"/></td></tr> <tr><td><input type="checkbox"/></td><td>1</td><td>3</td><td><input type="checkbox"/></td></tr> <tr><td><input type="checkbox"/></td><td>1</td><td>3</td><td><input type="checkbox"/></td></tr> <tr><td><input type="checkbox"/></td><td>1</td><td>4</td><td><input type="checkbox"/></td></tr> <tr><td><input type="checkbox"/></td><td>2</td><td>1</td><td><input type="checkbox"/></td></tr> <tr><td><input type="checkbox"/></td><td>-</td><td>-</td><td><input type="checkbox"/></td></tr> <tr><td><input type="checkbox"/></td><td>-</td><td>-</td><td><input type="checkbox"/></td></tr> <tr><td><input type="checkbox"/></td><td>-</td><td>-</td><td><input type="checkbox"/></td></tr> </tbody> </table> | LEFT SIDE LIGHTS | 2 | 2 | RIGHT SIDE LIGHTS | <input type="checkbox"/> | 2 | 2 | <input type="checkbox"/> | <input type="checkbox"/> | 4 | 4 | <input type="checkbox"/> | <input type="checkbox"/> | 3 | 3 | <input type="checkbox"/> | <input type="checkbox"/> | 1 | 2 | <input type="checkbox"/> | <input type="checkbox"/> | 2 | 4 | <input type="checkbox"/> | <input type="checkbox"/> | 1 | 3 | <input type="checkbox"/> | <input type="checkbox"/> | 1 | 3 | <input type="checkbox"/> | <input type="checkbox"/> | 1 | 3 | <input type="checkbox"/> | <input type="checkbox"/> | 1 | 4 | <input type="checkbox"/> | <input type="checkbox"/> | 2 | 1 | <input type="checkbox"/> | <input type="checkbox"/> | - | - | <input type="checkbox"/> | <input type="checkbox"/> | - | - | <input type="checkbox"/> | <input type="checkbox"/> | - | - | <input type="checkbox"/> | <p>Four-choice answers, 26 questions, 78 points</p> <p style="text-align: center;">Code: 9018</p> <table style="width: 100%; border-collapse: collapse;"> <thead> <tr> <th style="text-align: left;">LEFT SIDE LIGHTS</th> <th style="text-align: center;">2</th> <th style="text-align: center;">3</th> <th style="text-align: right;">RIGHT SIDE LIGHTS</th> </tr> </thead> <tbody> <tr><td><input type="checkbox"/></td><td>2</td><td>3</td><td><input type="checkbox"/></td></tr> <tr><td><input type="checkbox"/></td><td>1</td><td>4</td><td><input type="checkbox"/></td></tr> <tr><td><input type="checkbox"/></td><td>4</td><td>2</td><td><input type="checkbox"/></td></tr> <tr><td><input type="checkbox"/></td><td>1</td><td>4</td><td><input type="checkbox"/></td></tr> <tr><td><input type="checkbox"/></td><td>1</td><td>2</td><td><input type="checkbox"/></td></tr> <tr><td><input type="checkbox"/></td><td>3</td><td>3</td><td><input type="checkbox"/></td></tr> <tr><td><input type="checkbox"/></td><td>2</td><td>3</td><td><input type="checkbox"/></td></tr> <tr><td><input type="checkbox"/></td><td>4</td><td>1</td><td><input type="checkbox"/></td></tr> <tr><td><input type="checkbox"/></td><td>2</td><td>2</td><td><input type="checkbox"/></td></tr> <tr><td><input type="checkbox"/></td><td>4</td><td>3</td><td><input type="checkbox"/></td></tr> <tr><td><input type="checkbox"/></td><td>1</td><td>2</td><td><input type="checkbox"/></td></tr> <tr><td><input type="checkbox"/></td><td>3</td><td>2</td><td><input type="checkbox"/></td></tr> <tr><td><input type="checkbox"/></td><td>3</td><td>4</td><td><input type="checkbox"/></td></tr> </tbody> </table> | LEFT SIDE LIGHTS | 2 | 3 | RIGHT SIDE LIGHTS | <input type="checkbox"/> | 2 | 3 | <input type="checkbox"/> | <input type="checkbox"/> | 1 | 4 | <input type="checkbox"/> | <input type="checkbox"/> | 4 | 2 | <input type="checkbox"/> | <input type="checkbox"/> | 1 | 4 | <input type="checkbox"/> | <input type="checkbox"/> | 1 | 2 | <input type="checkbox"/> | <input type="checkbox"/> | 3 | 3 | <input type="checkbox"/> | <input type="checkbox"/> | 2 | 3 | <input type="checkbox"/> | <input type="checkbox"/> | 4 | 1 | <input type="checkbox"/> | <input type="checkbox"/> | 2 | 2 | <input type="checkbox"/> | <input type="checkbox"/> | 4 | 3 | <input type="checkbox"/> | <input type="checkbox"/> | 1 | 2 | <input type="checkbox"/> | <input type="checkbox"/> | 3 | 2 | <input type="checkbox"/> | <input type="checkbox"/> | 3 | 4 | <input type="checkbox"/> | <p>Four-choice answers, 26 questions, 78 points</p> <p style="text-align: center;">Code: 9471</p> <table style="width: 100%; border-collapse: collapse;"> <thead> <tr> <th style="text-align: left;">LEFT SIDE LIGHTS</th> <th style="text-align: center;">4</th> <th style="text-align: center;">2</th> <th style="text-align: right;">RIGHT SIDE LIGHTS</th> </tr> </thead> <tbody> <tr><td><input type="checkbox"/></td><td>4</td><td>2</td><td><input type="checkbox"/></td></tr> <tr><td><input type="checkbox"/></td><td>3</td><td>3</td><td><input type="checkbox"/></td></tr> <tr><td><input type="checkbox"/></td><td>1</td><td>2</td><td><input type="checkbox"/></td></tr> <tr><td><input type="checkbox"/></td><td>2</td><td>4</td><td><input type="checkbox"/></td></tr> <tr><td><input type="checkbox"/></td><td>1</td><td>1</td><td><input type="checkbox"/></td></tr> <tr><td><input type="checkbox"/></td><td>3</td><td>4</td><td><input type="checkbox"/></td></tr> <tr><td><input type="checkbox"/></td><td>4</td><td>1</td><td><input type="checkbox"/></td></tr> <tr><td><input type="checkbox"/></td><td>3</td><td>4</td><td><input type="checkbox"/></td></tr> <tr><td><input type="checkbox"/></td><td>3</td><td>4</td><td><input type="checkbox"/></td></tr> <tr><td><input type="checkbox"/></td><td>3</td><td>4</td><td><input type="checkbox"/></td></tr> <tr><td><input type="checkbox"/></td><td>3</td><td>2</td><td><input type="checkbox"/></td></tr> <tr><td><input type="checkbox"/></td><td>4</td><td>1</td><td><input type="checkbox"/></td></tr> <tr><td><input type="checkbox"/></td><td>1</td><td>2</td><td><input type="checkbox"/></td></tr> </tbody> </table> | LEFT SIDE LIGHTS | 4 | 2 | RIGHT SIDE LIGHTS | <input type="checkbox"/> | 4 | 2 | <input type="checkbox"/> | <input type="checkbox"/> | 3 | 3 | <input type="checkbox"/> | <input type="checkbox"/> | 1 | 2 | <input type="checkbox"/> | <input type="checkbox"/> | 2 | 4 | <input type="checkbox"/> | <input type="checkbox"/> | 1 | 1 | <input type="checkbox"/> | <input type="checkbox"/> | 3 | 4 | <input type="checkbox"/> | <input type="checkbox"/> | 4 | 1 | <input type="checkbox"/> | <input type="checkbox"/> | 3 | 4 | <input type="checkbox"/> | <input type="checkbox"/> | 3 | 4 | <input type="checkbox"/> | <input type="checkbox"/> | 3 | 4 | <input type="checkbox"/> | <input type="checkbox"/> | 3 | 2 | <input type="checkbox"/> | <input type="checkbox"/> | 4 | 1 | <input type="checkbox"/> | <input type="checkbox"/> | 1 | 2 | <input type="checkbox"/> | | | | | | | | | | | | |
| LEFT SIDE LIGHTS | 2 | 1 | RIGHT SIDE LIGHTS | | | | | | | | | | | | | | | | | | | | | | | | | | | | | | | | | | | | | | | | | | | | | | | | | | | | | | | | | | | | | | | | | | | | | | | | | | | | | | | | | | | | | | | | | | | | | | | | | | | | | | | | | | | | | | | | | | | | | | | | | | | | | | | | | | | | | | | | | | | | | | | | | | | | | | | | | | | | | | | | | | | | | | | | | | | | | | | | | | | | | | | | | | | | | | | | | | | | | | | | | | | | | | | | | | | | | | | | | | | | | | | | | | | | | | | | | | | | |
| <input type="checkbox"/> | 2 | 1 | <input type="checkbox"/> | | | | | | | | | | | | | | | | | | | | | | | | | | | | | | | | | | | | | | | | | | | | | | | | | | | | | | | | | | | | | | | | | | | | | | | | | | | | | | | | | | | | | | | | | | | | | | | | | | | | | | | | | | | | | | | | | | | | | | | | | | | | | | | | | | | | | | | | | | | | | | | | | | | | | | | | | | | | | | | | | | | | | | | | | | | | | | | | | | | | | | | | | | | | | | | | | | | | | | | | | | | | | | | | | | | | | | | | | | | | | | | | | | | | | | | | | | | | |
| <input type="checkbox"/> | 3 | 4 | <input type="checkbox"/> | | | | | | | | | | | | | | | | | | | | | | | | | | | | | | | | | | | | | | | | | | | | | | | | | | | | | | | | | | | | | | | | | | | | | | | | | | | | | | | | | | | | | | | | | | | | | | | | | | | | | | | | | | | | | | | | | | | | | | | | | | | | | | | | | | | | | | | | | | | | | | | | | | | | | | | | | | | | | | | | | | | | | | | | | | | | | | | | | | | | | | | | | | | | | | | | | | | | | | | | | | | | | | | | | | | | | | | | | | | | | | | | | | | | | | | | | | | | |
| <input type="checkbox"/> | 1 | 1 | <input type="checkbox"/> | | | | | | | | | | | | | | | | | | | | | | | | | | | | | | | | | | | | | | | | | | | | | | | | | | | | | | | | | | | | | | | | | | | | | | | | | | | | | | | | | | | | | | | | | | | | | | | | | | | | | | | | | | | | | | | | | | | | | | | | | | | | | | | | | | | | | | | | | | | | | | | | | | | | | | | | | | | | | | | | | | | | | | | | | | | | | | | | | | | | | | | | | | | | | | | | | | | | | | | | | | | | | | | | | | | | | | | | | | | | | | | | | | | | | | | | | | | | |
| <input type="checkbox"/> | 4 | 2 | <input type="checkbox"/> | | | | | | | | | | | | | | | | | | | | | | | | | | | | | | | | | | | | | | | | | | | | | | | | | | | | | | | | | | | | | | | | | | | | | | | | | | | | | | | | | | | | | | | | | | | | | | | | | | | | | | | | | | | | | | | | | | | | | | | | | | | | | | | | | | | | | | | | | | | | | | | | | | | | | | | | | | | | | | | | | | | | | | | | | | | | | | | | | | | | | | | | | | | | | | | | | | | | | | | | | | | | | | | | | | | | | | | | | | | | | | | | | | | | | | | | | | | | |
| <input type="checkbox"/> | 3 | 1 | <input type="checkbox"/> | | | | | | | | | | | | | | | | | | | | | | | | | | | | | | | | | | | | | | | | | | | | | | | | | | | | | | | | | | | | | | | | | | | | | | | | | | | | | | | | | | | | | | | | | | | | | | | | | | | | | | | | | | | | | | | | | | | | | | | | | | | | | | | | | | | | | | | | | | | | | | | | | | | | | | | | | | | | | | | | | | | | | | | | | | | | | | | | | | | | | | | | | | | | | | | | | | | | | | | | | | | | | | | | | | | | | | | | | | | | | | | | | | | | | | | | | | | | |
| <input type="checkbox"/> | 4 | 1 | <input type="checkbox"/> | | | | | | | | | | | | | | | | | | | | | | | | | | | | | | | | | | | | | | | | | | | | | | | | | | | | | | | | | | | | | | | | | | | | | | | | | | | | | | | | | | | | | | | | | | | | | | | | | | | | | | | | | | | | | | | | | | | | | | | | | | | | | | | | | | | | | | | | | | | | | | | | | | | | | | | | | | | | | | | | | | | | | | | | | | | | | | | | | | | | | | | | | | | | | | | | | | | | | | | | | | | | | | | | | | | | | | | | | | | | | | | | | | | | | | | | | | | | |
| <input type="checkbox"/> | 3 | 3 | <input type="checkbox"/> | | | | | | | | | | | | | | | | | | | | | | | | | | | | | | | | | | | | | | | | | | | | | | | | | | | | | | | | | | | | | | | | | | | | | | | | | | | | | | | | | | | | | | | | | | | | | | | | | | | | | | | | | | | | | | | | | | | | | | | | | | | | | | | | | | | | | | | | | | | | | | | | | | | | | | | | | | | | | | | | | | | | | | | | | | | | | | | | | | | | | | | | | | | | | | | | | | | | | | | | | | | | | | | | | | | | | | | | | | | | | | | | | | | | | | | | | | | | |
| <input type="checkbox"/> | 2 | 3 | <input type="checkbox"/> | | | | | | | | | | | | | | | | | | | | | | | | | | | | | | | | | | | | | | | | | | | | | | | | | | | | | | | | | | | | | | | | | | | | | | | | | | | | | | | | | | | | | | | | | | | | | | | | | | | | | | | | | | | | | | | | | | | | | | | | | | | | | | | | | | | | | | | | | | | | | | | | | | | | | | | | | | | | | | | | | | | | | | | | | | | | | | | | | | | | | | | | | | | | | | | | | | | | | | | | | | | | | | | | | | | | | | | | | | | | | | | | | | | | | | | | | | | | |
| <input type="checkbox"/> | 4 | 3 | <input type="checkbox"/> | | | | | | | | | | | | | | | | | | | | | | | | | | | | | | | | | | | | | | | | | | | | | | | | | | | | | | | | | | | | | | | | | | | | | | | | | | | | | | | | | | | | | | | | | | | | | | | | | | | | | | | | | | | | | | | | | | | | | | | | | | | | | | | | | | | | | | | | | | | | | | | | | | | | | | | | | | | | | | | | | | | | | | | | | | | | | | | | | | | | | | | | | | | | | | | | | | | | | | | | | | | | | | | | | | | | | | | | | | | | | | | | | | | | | | | | | | | | |
| <input type="checkbox"/> | 2 | 4 | <input type="checkbox"/> | | | | | | | | | | | | | | | | | | | | | | | | | | | | | | | | | | | | | | | | | | | | | | | | | | | | | | | | | | | | | | | | | | | | | | | | | | | | | | | | | | | | | | | | | | | | | | | | | | | | | | | | | | | | | | | | | | | | | | | | | | | | | | | | | | | | | | | | | | | | | | | | | | | | | | | | | | | | | | | | | | | | | | | | | | | | | | | | | | | | | | | | | | | | | | | | | | | | | | | | | | | | | | | | | | | | | | | | | | | | | | | | | | | | | | | | | | | | |
| <input type="checkbox"/> | - | - | <input type="checkbox"/> | | | | | | | | | | | | | | | | | | | | | | | | | | | | | | | | | | | | | | | | | | | | | | | | | | | | | | | | | | | | | | | | | | | | | | | | | | | | | | | | | | | | | | | | | | | | | | | | | | | | | | | | | | | | | | | | | | | | | | | | | | | | | | | | | | | | | | | | | | | | | | | | | | | | | | | | | | | | | | | | | | | | | | | | | | | | | | | | | | | | | | | | | | | | | | | | | | | | | | | | | | | | | | | | | | | | | | | | | | | | | | | | | | | | | | | | | | | | |
| <input type="checkbox"/> | - | - | <input type="checkbox"/> | | | | | | | | | | | | | | | | | | | | | | | | | | | | | | | | | | | | | | | | | | | | | | | | | | | | | | | | | | | | | | | | | | | | | | | | | | | | | | | | | | | | | | | | | | | | | | | | | | | | | | | | | | | | | | | | | | | | | | | | | | | | | | | | | | | | | | | | | | | | | | | | | | | | | | | | | | | | | | | | | | | | | | | | | | | | | | | | | | | | | | | | | | | | | | | | | | | | | | | | | | | | | | | | | | | | | | | | | | | | | | | | | | | | | | | | | | | | |
| <input type="checkbox"/> | - | - | <input type="checkbox"/> | | | | | | | | | | | | | | | | | | | | | | | | | | | | | | | | | | | | | | | | | | | | | | | | | | | | | | | | | | | | | | | | | | | | | | | | | | | | | | | | | | | | | | | | | | | | | | | | | | | | | | | | | | | | | | | | | | | | | | | | | | | | | | | | | | | | | | | | | | | | | | | | | | | | | | | | | | | | | | | | | | | | | | | | | | | | | | | | | | | | | | | | | | | | | | | | | | | | | | | | | | | | | | | | | | | | | | | | | | | | | | | | | | | | | | | | | | | | |
| LEFT SIDE LIGHTS | 2 | 2 | RIGHT SIDE LIGHTS | | | | | | | | | | | | | | | | | | | | | | | | | | | | | | | | | | | | | | | | | | | | | | | | | | | | | | | | | | | | | | | | | | | | | | | | | | | | | | | | | | | | | | | | | | | | | | | | | | | | | | | | | | | | | | | | | | | | | | | | | | | | | | | | | | | | | | | | | | | | | | | | | | | | | | | | | | | | | | | | | | | | | | | | | | | | | | | | | | | | | | | | | | | | | | | | | | | | | | | | | | | | | | | | | | | | | | | | | | | | | | | | | | | | | | | | | | | | |
| <input type="checkbox"/> | 2 | 2 | <input type="checkbox"/> | | | | | | | | | | | | | | | | | | | | | | | | | | | | | | | | | | | | | | | | | | | | | | | | | | | | | | | | | | | | | | | | | | | | | | | | | | | | | | | | | | | | | | | | | | | | | | | | | | | | | | | | | | | | | | | | | | | | | | | | | | | | | | | | | | | | | | | | | | | | | | | | | | | | | | | | | | | | | | | | | | | | | | | | | | | | | | | | | | | | | | | | | | | | | | | | | | | | | | | | | | | | | | | | | | | | | | | | | | | | | | | | | | | | | | | | | | | | |
| <input type="checkbox"/> | 4 | 4 | <input type="checkbox"/> | | | | | | | | | | | | | | | | | | | | | | | | | | | | | | | | | | | | | | | | | | | | | | | | | | | | | | | | | | | | | | | | | | | | | | | | | | | | | | | | | | | | | | | | | | | | | | | | | | | | | | | | | | | | | | | | | | | | | | | | | | | | | | | | | | | | | | | | | | | | | | | | | | | | | | | | | | | | | | | | | | | | | | | | | | | | | | | | | | | | | | | | | | | | | | | | | | | | | | | | | | | | | | | | | | | | | | | | | | | | | | | | | | | | | | | | | | | | |
| <input type="checkbox"/> | 3 | 3 | <input type="checkbox"/> | | | | | | | | | | | | | | | | | | | | | | | | | | | | | | | | | | | | | | | | | | | | | | | | | | | | | | | | | | | | | | | | | | | | | | | | | | | | | | | | | | | | | | | | | | | | | | | | | | | | | | | | | | | | | | | | | | | | | | | | | | | | | | | | | | | | | | | | | | | | | | | | | | | | | | | | | | | | | | | | | | | | | | | | | | | | | | | | | | | | | | | | | | | | | | | | | | | | | | | | | | | | | | | | | | | | | | | | | | | | | | | | | | | | | | | | | | | | |
| <input type="checkbox"/> | 1 | 2 | <input type="checkbox"/> | | | | | | | | | | | | | | | | | | | | | | | | | | | | | | | | | | | | | | | | | | | | | | | | | | | | | | | | | | | | | | | | | | | | | | | | | | | | | | | | | | | | | | | | | | | | | | | | | | | | | | | | | | | | | | | | | | | | | | | | | | | | | | | | | | | | | | | | | | | | | | | | | | | | | | | | | | | | | | | | | | | | | | | | | | | | | | | | | | | | | | | | | | | | | | | | | | | | | | | | | | | | | | | | | | | | | | | | | | | | | | | | | | | | | | | | | | | | |
| <input type="checkbox"/> | 2 | 4 | <input type="checkbox"/> | | | | | | | | | | | | | | | | | | | | | | | | | | | | | | | | | | | | | | | | | | | | | | | | | | | | | | | | | | | | | | | | | | | | | | | | | | | | | | | | | | | | | | | | | | | | | | | | | | | | | | | | | | | | | | | | | | | | | | | | | | | | | | | | | | | | | | | | | | | | | | | | | | | | | | | | | | | | | | | | | | | | | | | | | | | | | | | | | | | | | | | | | | | | | | | | | | | | | | | | | | | | | | | | | | | | | | | | | | | | | | | | | | | | | | | | | | | | |
| <input type="checkbox"/> | 1 | 3 | <input type="checkbox"/> | | | | | | | | | | | | | | | | | | | | | | | | | | | | | | | | | | | | | | | | | | | | | | | | | | | | | | | | | | | | | | | | | | | | | | | | | | | | | | | | | | | | | | | | | | | | | | | | | | | | | | | | | | | | | | | | | | | | | | | | | | | | | | | | | | | | | | | | | | | | | | | | | | | | | | | | | | | | | | | | | | | | | | | | | | | | | | | | | | | | | | | | | | | | | | | | | | | | | | | | | | | | | | | | | | | | | | | | | | | | | | | | | | | | | | | | | | | | |
| <input type="checkbox"/> | 1 | 3 | <input type="checkbox"/> | | | | | | | | | | | | | | | | | | | | | | | | | | | | | | | | | | | | | | | | | | | | | | | | | | | | | | | | | | | | | | | | | | | | | | | | | | | | | | | | | | | | | | | | | | | | | | | | | | | | | | | | | | | | | | | | | | | | | | | | | | | | | | | | | | | | | | | | | | | | | | | | | | | | | | | | | | | | | | | | | | | | | | | | | | | | | | | | | | | | | | | | | | | | | | | | | | | | | | | | | | | | | | | | | | | | | | | | | | | | | | | | | | | | | | | | | | | | |
| <input type="checkbox"/> | 1 | 3 | <input type="checkbox"/> | | | | | | | | | | | | | | | | | | | | | | | | | | | | | | | | | | | | | | | | | | | | | | | | | | | | | | | | | | | | | | | | | | | | | | | | | | | | | | | | | | | | | | | | | | | | | | | | | | | | | | | | | | | | | | | | | | | | | | | | | | | | | | | | | | | | | | | | | | | | | | | | | | | | | | | | | | | | | | | | | | | | | | | | | | | | | | | | | | | | | | | | | | | | | | | | | | | | | | | | | | | | | | | | | | | | | | | | | | | | | | | | | | | | | | | | | | | | |
| <input type="checkbox"/> | 1 | 4 | <input type="checkbox"/> | | | | | | | | | | | | | | | | | | | | | | | | | | | | | | | | | | | | | | | | | | | | | | | | | | | | | | | | | | | | | | | | | | | | | | | | | | | | | | | | | | | | | | | | | | | | | | | | | | | | | | | | | | | | | | | | | | | | | | | | | | | | | | | | | | | | | | | | | | | | | | | | | | | | | | | | | | | | | | | | | | | | | | | | | | | | | | | | | | | | | | | | | | | | | | | | | | | | | | | | | | | | | | | | | | | | | | | | | | | | | | | | | | | | | | | | | | | | |
| <input type="checkbox"/> | 2 | 1 | <input type="checkbox"/> | | | | | | | | | | | | | | | | | | | | | | | | | | | | | | | | | | | | | | | | | | | | | | | | | | | | | | | | | | | | | | | | | | | | | | | | | | | | | | | | | | | | | | | | | | | | | | | | | | | | | | | | | | | | | | | | | | | | | | | | | | | | | | | | | | | | | | | | | | | | | | | | | | | | | | | | | | | | | | | | | | | | | | | | | | | | | | | | | | | | | | | | | | | | | | | | | | | | | | | | | | | | | | | | | | | | | | | | | | | | | | | | | | | | | | | | | | | | |
| <input type="checkbox"/> | - | - | <input type="checkbox"/> | | | | | | | | | | | | | | | | | | | | | | | | | | | | | | | | | | | | | | | | | | | | | | | | | | | | | | | | | | | | | | | | | | | | | | | | | | | | | | | | | | | | | | | | | | | | | | | | | | | | | | | | | | | | | | | | | | | | | | | | | | | | | | | | | | | | | | | | | | | | | | | | | | | | | | | | | | | | | | | | | | | | | | | | | | | | | | | | | | | | | | | | | | | | | | | | | | | | | | | | | | | | | | | | | | | | | | | | | | | | | | | | | | | | | | | | | | | | |
| <input type="checkbox"/> | - | - | <input type="checkbox"/> | | | | | | | | | | | | | | | | | | | | | | | | | | | | | | | | | | | | | | | | | | | | | | | | | | | | | | | | | | | | | | | | | | | | | | | | | | | | | | | | | | | | | | | | | | | | | | | | | | | | | | | | | | | | | | | | | | | | | | | | | | | | | | | | | | | | | | | | | | | | | | | | | | | | | | | | | | | | | | | | | | | | | | | | | | | | | | | | | | | | | | | | | | | | | | | | | | | | | | | | | | | | | | | | | | | | | | | | | | | | | | | | | | | | | | | | | | | | |
| <input type="checkbox"/> | - | - | <input type="checkbox"/> | | | | | | | | | | | | | | | | | | | | | | | | | | | | | | | | | | | | | | | | | | | | | | | | | | | | | | | | | | | | | | | | | | | | | | | | | | | | | | | | | | | | | | | | | | | | | | | | | | | | | | | | | | | | | | | | | | | | | | | | | | | | | | | | | | | | | | | | | | | | | | | | | | | | | | | | | | | | | | | | | | | | | | | | | | | | | | | | | | | | | | | | | | | | | | | | | | | | | | | | | | | | | | | | | | | | | | | | | | | | | | | | | | | | | | | | | | | | |
| LEFT SIDE LIGHTS | 2 | 3 | RIGHT SIDE LIGHTS | | | | | | | | | | | | | | | | | | | | | | | | | | | | | | | | | | | | | | | | | | | | | | | | | | | | | | | | | | | | | | | | | | | | | | | | | | | | | | | | | | | | | | | | | | | | | | | | | | | | | | | | | | | | | | | | | | | | | | | | | | | | | | | | | | | | | | | | | | | | | | | | | | | | | | | | | | | | | | | | | | | | | | | | | | | | | | | | | | | | | | | | | | | | | | | | | | | | | | | | | | | | | | | | | | | | | | | | | | | | | | | | | | | | | | | | | | | | |
| <input type="checkbox"/> | 2 | 3 | <input type="checkbox"/> | | | | | | | | | | | | | | | | | | | | | | | | | | | | | | | | | | | | | | | | | | | | | | | | | | | | | | | | | | | | | | | | | | | | | | | | | | | | | | | | | | | | | | | | | | | | | | | | | | | | | | | | | | | | | | | | | | | | | | | | | | | | | | | | | | | | | | | | | | | | | | | | | | | | | | | | | | | | | | | | | | | | | | | | | | | | | | | | | | | | | | | | | | | | | | | | | | | | | | | | | | | | | | | | | | | | | | | | | | | | | | | | | | | | | | | | | | | | |
| <input type="checkbox"/> | 1 | 4 | <input type="checkbox"/> | | | | | | | | | | | | | | | | | | | | | | | | | | | | | | | | | | | | | | | | | | | | | | | | | | | | | | | | | | | | | | | | | | | | | | | | | | | | | | | | | | | | | | | | | | | | | | | | | | | | | | | | | | | | | | | | | | | | | | | | | | | | | | | | | | | | | | | | | | | | | | | | | | | | | | | | | | | | | | | | | | | | | | | | | | | | | | | | | | | | | | | | | | | | | | | | | | | | | | | | | | | | | | | | | | | | | | | | | | | | | | | | | | | | | | | | | | | | |
| <input type="checkbox"/> | 4 | 2 | <input type="checkbox"/> | | | | | | | | | | | | | | | | | | | | | | | | | | | | | | | | | | | | | | | | | | | | | | | | | | | | | | | | | | | | | | | | | | | | | | | | | | | | | | | | | | | | | | | | | | | | | | | | | | | | | | | | | | | | | | | | | | | | | | | | | | | | | | | | | | | | | | | | | | | | | | | | | | | | | | | | | | | | | | | | | | | | | | | | | | | | | | | | | | | | | | | | | | | | | | | | | | | | | | | | | | | | | | | | | | | | | | | | | | | | | | | | | | | | | | | | | | | | |
| <input type="checkbox"/> | 1 | 4 | <input type="checkbox"/> | | | | | | | | | | | | | | | | | | | | | | | | | | | | | | | | | | | | | | | | | | | | | | | | | | | | | | | | | | | | | | | | | | | | | | | | | | | | | | | | | | | | | | | | | | | | | | | | | | | | | | | | | | | | | | | | | | | | | | | | | | | | | | | | | | | | | | | | | | | | | | | | | | | | | | | | | | | | | | | | | | | | | | | | | | | | | | | | | | | | | | | | | | | | | | | | | | | | | | | | | | | | | | | | | | | | | | | | | | | | | | | | | | | | | | | | | | | | |
| <input type="checkbox"/> | 1 | 2 | <input type="checkbox"/> | | | | | | | | | | | | | | | | | | | | | | | | | | | | | | | | | | | | | | | | | | | | | | | | | | | | | | | | | | | | | | | | | | | | | | | | | | | | | | | | | | | | | | | | | | | | | | | | | | | | | | | | | | | | | | | | | | | | | | | | | | | | | | | | | | | | | | | | | | | | | | | | | | | | | | | | | | | | | | | | | | | | | | | | | | | | | | | | | | | | | | | | | | | | | | | | | | | | | | | | | | | | | | | | | | | | | | | | | | | | | | | | | | | | | | | | | | | | |
| <input type="checkbox"/> | 3 | 3 | <input type="checkbox"/> | | | | | | | | | | | | | | | | | | | | | | | | | | | | | | | | | | | | | | | | | | | | | | | | | | | | | | | | | | | | | | | | | | | | | | | | | | | | | | | | | | | | | | | | | | | | | | | | | | | | | | | | | | | | | | | | | | | | | | | | | | | | | | | | | | | | | | | | | | | | | | | | | | | | | | | | | | | | | | | | | | | | | | | | | | | | | | | | | | | | | | | | | | | | | | | | | | | | | | | | | | | | | | | | | | | | | | | | | | | | | | | | | | | | | | | | | | | | |
| <input type="checkbox"/> | 2 | 3 | <input type="checkbox"/> | | | | | | | | | | | | | | | | | | | | | | | | | | | | | | | | | | | | | | | | | | | | | | | | | | | | | | | | | | | | | | | | | | | | | | | | | | | | | | | | | | | | | | | | | | | | | | | | | | | | | | | | | | | | | | | | | | | | | | | | | | | | | | | | | | | | | | | | | | | | | | | | | | | | | | | | | | | | | | | | | | | | | | | | | | | | | | | | | | | | | | | | | | | | | | | | | | | | | | | | | | | | | | | | | | | | | | | | | | | | | | | | | | | | | | | | | | | | |
| <input type="checkbox"/> | 4 | 1 | <input type="checkbox"/> | | | | | | | | | | | | | | | | | | | | | | | | | | | | | | | | | | | | | | | | | | | | | | | | | | | | | | | | | | | | | | | | | | | | | | | | | | | | | | | | | | | | | | | | | | | | | | | | | | | | | | | | | | | | | | | | | | | | | | | | | | | | | | | | | | | | | | | | | | | | | | | | | | | | | | | | | | | | | | | | | | | | | | | | | | | | | | | | | | | | | | | | | | | | | | | | | | | | | | | | | | | | | | | | | | | | | | | | | | | | | | | | | | | | | | | | | | | | |
| <input type="checkbox"/> | 2 | 2 | <input type="checkbox"/> | | | | | | | | | | | | | | | | | | | | | | | | | | | | | | | | | | | | | | | | | | | | | | | | | | | | | | | | | | | | | | | | | | | | | | | | | | | | | | | | | | | | | | | | | | | | | | | | | | | | | | | | | | | | | | | | | | | | | | | | | | | | | | | | | | | | | | | | | | | | | | | | | | | | | | | | | | | | | | | | | | | | | | | | | | | | | | | | | | | | | | | | | | | | | | | | | | | | | | | | | | | | | | | | | | | | | | | | | | | | | | | | | | | | | | | | | | | | |
| <input type="checkbox"/> | 4 | 3 | <input type="checkbox"/> | | | | | | | | | | | | | | | | | | | | | | | | | | | | | | | | | | | | | | | | | | | | | | | | | | | | | | | | | | | | | | | | | | | | | | | | | | | | | | | | | | | | | | | | | | | | | | | | | | | | | | | | | | | | | | | | | | | | | | | | | | | | | | | | | | | | | | | | | | | | | | | | | | | | | | | | | | | | | | | | | | | | | | | | | | | | | | | | | | | | | | | | | | | | | | | | | | | | | | | | | | | | | | | | | | | | | | | | | | | | | | | | | | | | | | | | | | | | |
| <input type="checkbox"/> | 1 | 2 | <input type="checkbox"/> | | | | | | | | | | | | | | | | | | | | | | | | | | | | | | | | | | | | | | | | | | | | | | | | | | | | | | | | | | | | | | | | | | | | | | | | | | | | | | | | | | | | | | | | | | | | | | | | | | | | | | | | | | | | | | | | | | | | | | | | | | | | | | | | | | | | | | | | | | | | | | | | | | | | | | | | | | | | | | | | | | | | | | | | | | | | | | | | | | | | | | | | | | | | | | | | | | | | | | | | | | | | | | | | | | | | | | | | | | | | | | | | | | | | | | | | | | | | |
| <input type="checkbox"/> | 3 | 2 | <input type="checkbox"/> | | | | | | | | | | | | | | | | | | | | | | | | | | | | | | | | | | | | | | | | | | | | | | | | | | | | | | | | | | | | | | | | | | | | | | | | | | | | | | | | | | | | | | | | | | | | | | | | | | | | | | | | | | | | | | | | | | | | | | | | | | | | | | | | | | | | | | | | | | | | | | | | | | | | | | | | | | | | | | | | | | | | | | | | | | | | | | | | | | | | | | | | | | | | | | | | | | | | | | | | | | | | | | | | | | | | | | | | | | | | | | | | | | | | | | | | | | | | |
| <input type="checkbox"/> | 3 | 4 | <input type="checkbox"/> | | | | | | | | | | | | | | | | | | | | | | | | | | | | | | | | | | | | | | | | | | | | | | | | | | | | | | | | | | | | | | | | | | | | | | | | | | | | | | | | | | | | | | | | | | | | | | | | | | | | | | | | | | | | | | | | | | | | | | | | | | | | | | | | | | | | | | | | | | | | | | | | | | | | | | | | | | | | | | | | | | | | | | | | | | | | | | | | | | | | | | | | | | | | | | | | | | | | | | | | | | | | | | | | | | | | | | | | | | | | | | | | | | | | | | | | | | | | |
| LEFT SIDE LIGHTS | 4 | 2 | RIGHT SIDE LIGHTS | | | | | | | | | | | | | | | | | | | | | | | | | | | | | | | | | | | | | | | | | | | | | | | | | | | | | | | | | | | | | | | | | | | | | | | | | | | | | | | | | | | | | | | | | | | | | | | | | | | | | | | | | | | | | | | | | | | | | | | | | | | | | | | | | | | | | | | | | | | | | | | | | | | | | | | | | | | | | | | | | | | | | | | | | | | | | | | | | | | | | | | | | | | | | | | | | | | | | | | | | | | | | | | | | | | | | | | | | | | | | | | | | | | | | | | | | | | | |
| <input type="checkbox"/> | 4 | 2 | <input type="checkbox"/> | | | | | | | | | | | | | | | | | | | | | | | | | | | | | | | | | | | | | | | | | | | | | | | | | | | | | | | | | | | | | | | | | | | | | | | | | | | | | | | | | | | | | | | | | | | | | | | | | | | | | | | | | | | | | | | | | | | | | | | | | | | | | | | | | | | | | | | | | | | | | | | | | | | | | | | | | | | | | | | | | | | | | | | | | | | | | | | | | | | | | | | | | | | | | | | | | | | | | | | | | | | | | | | | | | | | | | | | | | | | | | | | | | | | | | | | | | | | |
| <input type="checkbox"/> | 3 | 3 | <input type="checkbox"/> | | | | | | | | | | | | | | | | | | | | | | | | | | | | | | | | | | | | | | | | | | | | | | | | | | | | | | | | | | | | | | | | | | | | | | | | | | | | | | | | | | | | | | | | | | | | | | | | | | | | | | | | | | | | | | | | | | | | | | | | | | | | | | | | | | | | | | | | | | | | | | | | | | | | | | | | | | | | | | | | | | | | | | | | | | | | | | | | | | | | | | | | | | | | | | | | | | | | | | | | | | | | | | | | | | | | | | | | | | | | | | | | | | | | | | | | | | | | |
| <input type="checkbox"/> | 1 | 2 | <input type="checkbox"/> | | | | | | | | | | | | | | | | | | | | | | | | | | | | | | | | | | | | | | | | | | | | | | | | | | | | | | | | | | | | | | | | | | | | | | | | | | | | | | | | | | | | | | | | | | | | | | | | | | | | | | | | | | | | | | | | | | | | | | | | | | | | | | | | | | | | | | | | | | | | | | | | | | | | | | | | | | | | | | | | | | | | | | | | | | | | | | | | | | | | | | | | | | | | | | | | | | | | | | | | | | | | | | | | | | | | | | | | | | | | | | | | | | | | | | | | | | | | |
| <input type="checkbox"/> | 2 | 4 | <input type="checkbox"/> | | | | | | | | | | | | | | | | | | | | | | | | | | | | | | | | | | | | | | | | | | | | | | | | | | | | | | | | | | | | | | | | | | | | | | | | | | | | | | | | | | | | | | | | | | | | | | | | | | | | | | | | | | | | | | | | | | | | | | | | | | | | | | | | | | | | | | | | | | | | | | | | | | | | | | | | | | | | | | | | | | | | | | | | | | | | | | | | | | | | | | | | | | | | | | | | | | | | | | | | | | | | | | | | | | | | | | | | | | | | | | | | | | | | | | | | | | | | |
| <input type="checkbox"/> | 1 | 1 | <input type="checkbox"/> | | | | | | | | | | | | | | | | | | | | | | | | | | | | | | | | | | | | | | | | | | | | | | | | | | | | | | | | | | | | | | | | | | | | | | | | | | | | | | | | | | | | | | | | | | | | | | | | | | | | | | | | | | | | | | | | | | | | | | | | | | | | | | | | | | | | | | | | | | | | | | | | | | | | | | | | | | | | | | | | | | | | | | | | | | | | | | | | | | | | | | | | | | | | | | | | | | | | | | | | | | | | | | | | | | | | | | | | | | | | | | | | | | | | | | | | | | | | |
| <input type="checkbox"/> | 3 | 4 | <input type="checkbox"/> | | | | | | | | | | | | | | | | | | | | | | | | | | | | | | | | | | | | | | | | | | | | | | | | | | | | | | | | | | | | | | | | | | | | | | | | | | | | | | | | | | | | | | | | | | | | | | | | | | | | | | | | | | | | | | | | | | | | | | | | | | | | | | | | | | | | | | | | | | | | | | | | | | | | | | | | | | | | | | | | | | | | | | | | | | | | | | | | | | | | | | | | | | | | | | | | | | | | | | | | | | | | | | | | | | | | | | | | | | | | | | | | | | | | | | | | | | | | |
| <input type="checkbox"/> | 4 | 1 | <input type="checkbox"/> | | | | | | | | | | | | | | | | | | | | | | | | | | | | | | | | | | | | | | | | | | | | | | | | | | | | | | | | | | | | | | | | | | | | | | | | | | | | | | | | | | | | | | | | | | | | | | | | | | | | | | | | | | | | | | | | | | | | | | | | | | | | | | | | | | | | | | | | | | | | | | | | | | | | | | | | | | | | | | | | | | | | | | | | | | | | | | | | | | | | | | | | | | | | | | | | | | | | | | | | | | | | | | | | | | | | | | | | | | | | | | | | | | | | | | | | | | | | |
| <input type="checkbox"/> | 3 | 4 | <input type="checkbox"/> | | | | | | | | | | | | | | | | | | | | | | | | | | | | | | | | | | | | | | | | | | | | | | | | | | | | | | | | | | | | | | | | | | | | | | | | | | | | | | | | | | | | | | | | | | | | | | | | | | | | | | | | | | | | | | | | | | | | | | | | | | | | | | | | | | | | | | | | | | | | | | | | | | | | | | | | | | | | | | | | | | | | | | | | | | | | | | | | | | | | | | | | | | | | | | | | | | | | | | | | | | | | | | | | | | | | | | | | | | | | | | | | | | | | | | | | | | | | |
| <input type="checkbox"/> | 3 | 4 | <input type="checkbox"/> | | | | | | | | | | | | | | | | | | | | | | | | | | | | | | | | | | | | | | | | | | | | | | | | | | | | | | | | | | | | | | | | | | | | | | | | | | | | | | | | | | | | | | | | | | | | | | | | | | | | | | | | | | | | | | | | | | | | | | | | | | | | | | | | | | | | | | | | | | | | | | | | | | | | | | | | | | | | | | | | | | | | | | | | | | | | | | | | | | | | | | | | | | | | | | | | | | | | | | | | | | | | | | | | | | | | | | | | | | | | | | | | | | | | | | | | | | | | |
| <input type="checkbox"/> | 3 | 4 | <input type="checkbox"/> | | | | | | | | | | | | | | | | | | | | | | | | | | | | | | | | | | | | | | | | | | | | | | | | | | | | | | | | | | | | | | | | | | | | | | | | | | | | | | | | | | | | | | | | | | | | | | | | | | | | | | | | | | | | | | | | | | | | | | | | | | | | | | | | | | | | | | | | | | | | | | | | | | | | | | | | | | | | | | | | | | | | | | | | | | | | | | | | | | | | | | | | | | | | | | | | | | | | | | | | | | | | | | | | | | | | | | | | | | | | | | | | | | | | | | | | | | | | |
| <input type="checkbox"/> | 3 | 2 | <input type="checkbox"/> | | | | | | | | | | | | | | | | | | | | | | | | | | | | | | | | | | | | | | | | | | | | | | | | | | | | | | | | | | | | | | | | | | | | | | | | | | | | | | | | | | | | | | | | | | | | | | | | | | | | | | | | | | | | | | | | | | | | | | | | | | | | | | | | | | | | | | | | | | | | | | | | | | | | | | | | | | | | | | | | | | | | | | | | | | | | | | | | | | | | | | | | | | | | | | | | | | | | | | | | | | | | | | | | | | | | | | | | | | | | | | | | | | | | | | | | | | | | |
| <input type="checkbox"/> | 4 | 1 | <input type="checkbox"/> | | | | | | | | | | | | | | | | | | | | | | | | | | | | | | | | | | | | | | | | | | | | | | | | | | | | | | | | | | | | | | | | | | | | | | | | | | | | | | | | | | | | | | | | | | | | | | | | | | | | | | | | | | | | | | | | | | | | | | | | | | | | | | | | | | | | | | | | | | | | | | | | | | | | | | | | | | | | | | | | | | | | | | | | | | | | | | | | | | | | | | | | | | | | | | | | | | | | | | | | | | | | | | | | | | | | | | | | | | | | | | | | | | | | | | | | | | | | |
| <input type="checkbox"/> | 1 | 2 | <input type="checkbox"/> | | | | | | | | | | | | | | | | | | | | | | | | | | | | | | | | | | | | | | | | | | | | | | | | | | | | | | | | | | | | | | | | | | | | | | | | | | | | | | | | | | | | | | | | | | | | | | | | | | | | | | | | | | | | | | | | | | | | | | | | | | | | | | | | | | | | | | | | | | | | | | | | | | | | | | | | | | | | | | | | | | | | | | | | | | | | | | | | | | | | | | | | | | | | | | | | | | | | | | | | | | | | | | | | | | | | | | | | | | | | | | | | | | | | | | | | | | | | |

IF YOUR GEOSAFARI FAILS TO OPERATE PROPERLY

1. Check the batteries—Weak batteries can cause a variety of malfunctions. Dim lights are the first sign of weak or drained batteries. Replace the batteries with a fresh set. If your unit will not be used for a long period of time, remove the batteries to prevent possible corrosion.
2. Incorrect adapter—**WARNING:** Adapters not designed for the **GeoSafari** can cause permanent damage to the machine's electronics. Use of any adapter other than the adapter especially designed for **GeoSafari** will void your warranty.
3. Be sure the adapter plug is inserted securely into the machine, and the adapter body into the wall outlet.
4. If your unit is a school model (**GeoSafari EI-8866**), no sound will be heard from the loudspeaker if a headset is plugged into either jack.

NOTE: When the adapter is used, it will not drain the batteries.